

ESTE MES CONOCEMOS

A...

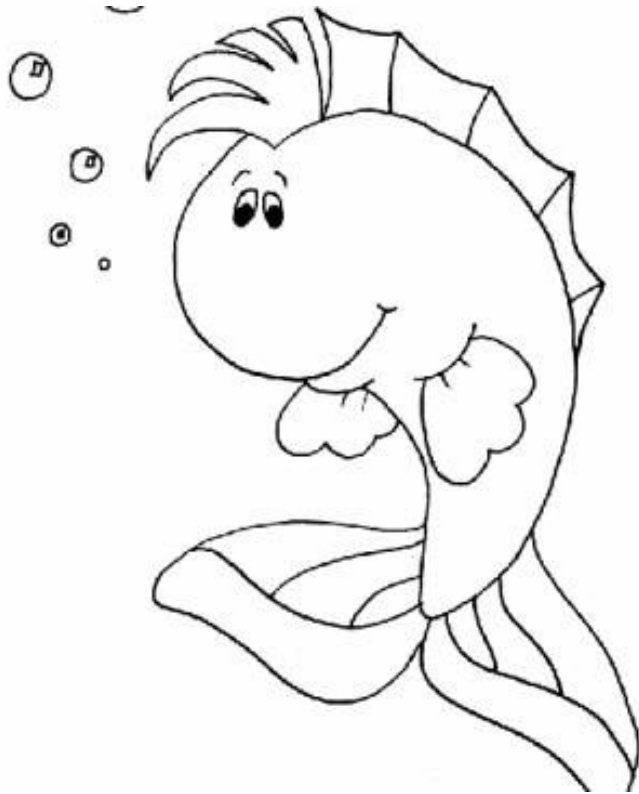

CONTENIDOS:

- El Colegio
- El Cuerpo
- Dentro/fuera
- Grande/pequeño
 - El Círculo
 - El fonema i
- Números del 1 al 4

EL PEZ QUE NO QUERÍA IR AL COLEGIO

¡Qué gran susto se llevó el pez Tris por no gustarle ir a la escuela y no saber leer! ¿queréis saber qué le pasó a este pez? pues aquí comienza la historia.

Érase una vez un burrito llamado el burro orejas, que después de unos laboriosos años de trabajo, gozaba de un buen merecido descanso.

Pero tan acostumbrado estaba a trabajar que no podía estar sin hacer nada, así que paseando un día a la orilla del río tuvo una brillante idea:

- Eso es, cada día vendré al río a pescar y así me distraeré.

Y desde entonces, sentado sobre el viejo puente que cruzaba el río, el burro orejas lanzaba el anzuelo al río y esperaba a que los peces picaran.

¡Qué emoción al sentir el tirón dado por el pez y luego la anhelada espera de tirar del hilo hasta ver el pez agitándose al extremo del anzuelo!

Pero lo que era ocasión de alegría para el burro, lo era de tristeza para los peces que vivían en el río.



Al ver cómo él burro orejas iba capturándolos, se reunieron todos para encontrar el modo de librarse de él.

Después de mucho cavilar decidieron poner en el lugar donde siempre pescaba el burro orejas, debajo del puente, un **¡ATENCIÓN! ¡PELIGRO! ¡AQUÍ PESCA OREJAS!**

letrero con la inscripción con letras bien grandes:

Desde aquel día, orejas no comprendía por qué no cogía ya ningún pez. y se rascaba, pensativo la cabeza pensando en el extraño misterio.

Pero en el río había un pececito llamado tris que al salir de casa, en lugar de ir a la escuela, solía dar grandes paseos por todos los recovecos del río. para él era más emocionante nadar de un lado para otro que estar en clase, sentado, dibujando, escribiendo, contando.

Y claro está, nunca iba a la escuela y no sabía leer.



Un día en una de sus correrías aventureras llegó debajo del puente, al lugar donde los peces habían puesto el gran letrero.

Tris lo vio ¿por qué habrán puesto aquí esto? ¿qué dirán estas letras?

En ese momento su atención se vio atraída por un delicioso gusano que se columpiaba en el agua.

-¡Bocado exquisito! - pensó tris.

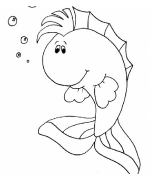

E.E.I. MAR DE ALBORÁN

Y abría su boca para tragárselo cuando...

De pronto, ¡Zas! el viejo puente sobre el que se sentaba orejas se derrumbó y éste se vio sumergido en el agua. el pobre burrito lo pasó mal, pero pudo ver el letrero de peligro que los peces habían puesto.

Cómo era viejo y le resultaba difícil salir del agua porque los huesos le pesaban mucho, los peces, compadecidos de él, le ayudaron a salir.

El burro orejas les prometió que nunca más iría a pescar. y los peces le pidieron que se acercara a la orilla, y él y ellos hablarían contándose cosas.

Tris recibió un soberano susto al ver lo cerca que estuvo de morir pescado por no saber leer y ya nunca más dejó de ir a la escuela. y ¿sabéis?, llegó a comprender que ir a clase era tan emocionante como pasear a lo ancho y largo del río.

Y COLORÍN, COLORADO,

ESTE CUENTO SE HA ACABADO.



EL PEZ QUE

E.E.I. MAR DE ALBORÁN



NO QUERÍA

IR AL

COLEGIO

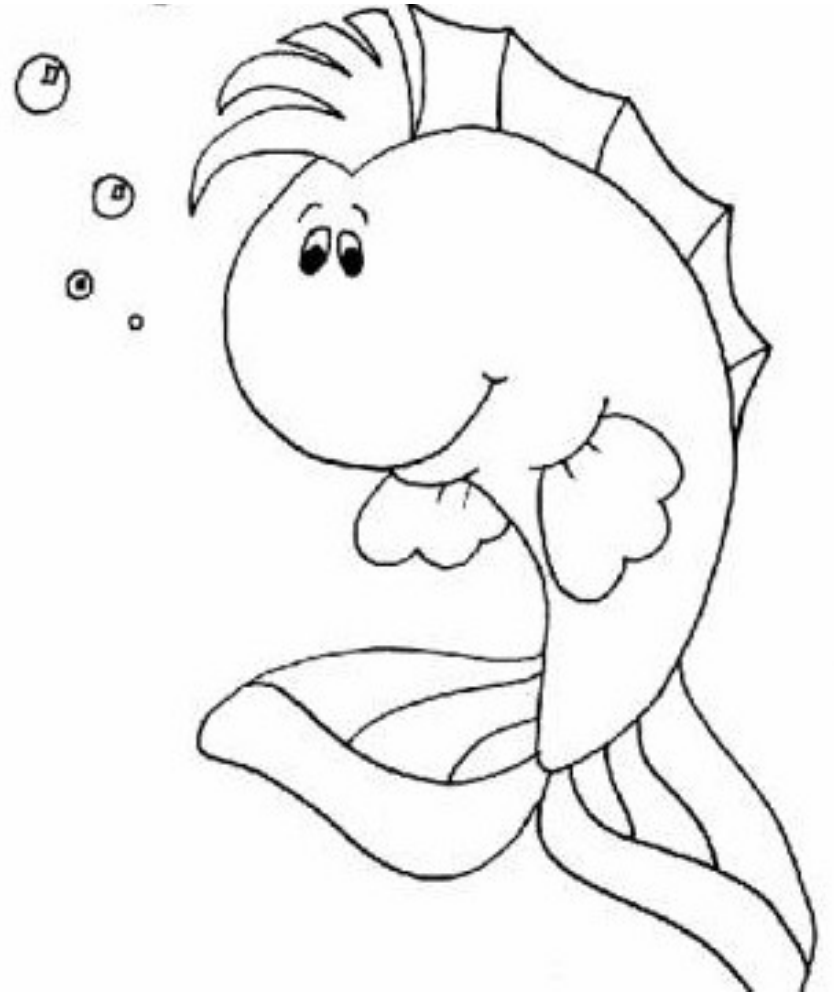

DIÁLOGO COMPASIÓN



HAY QUE
SER
RESPONSABLE

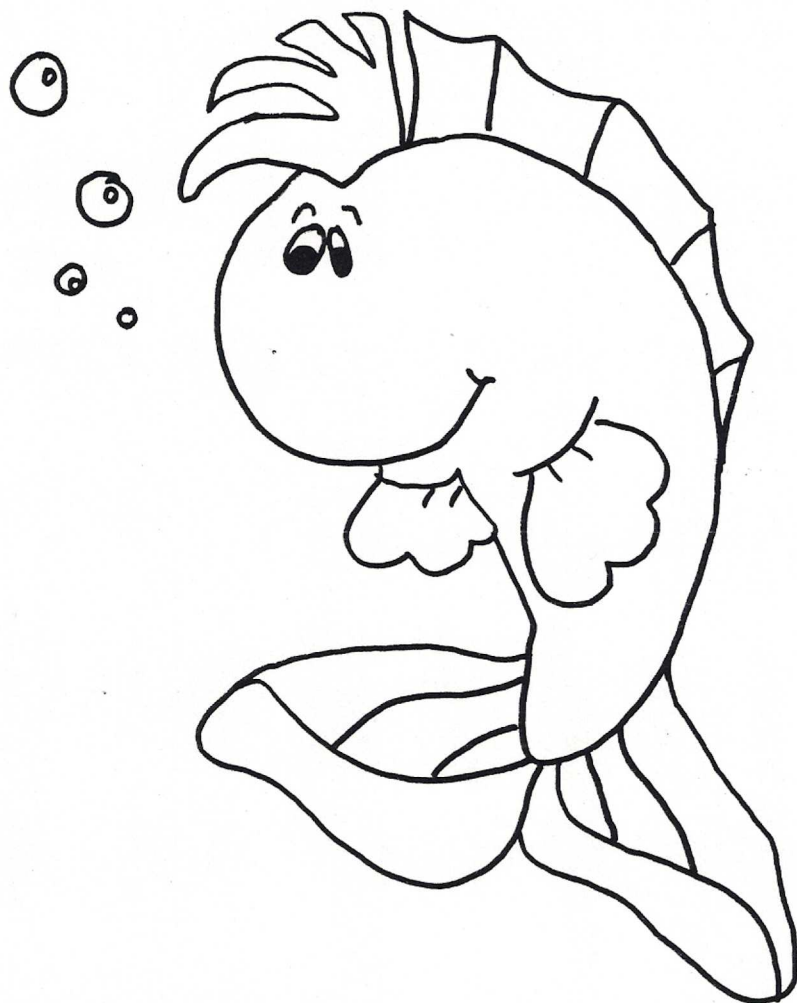

TRABAJO ALEGRÍA



• *Hacer* libremente círculos siguiendo la dirección de la flecha.

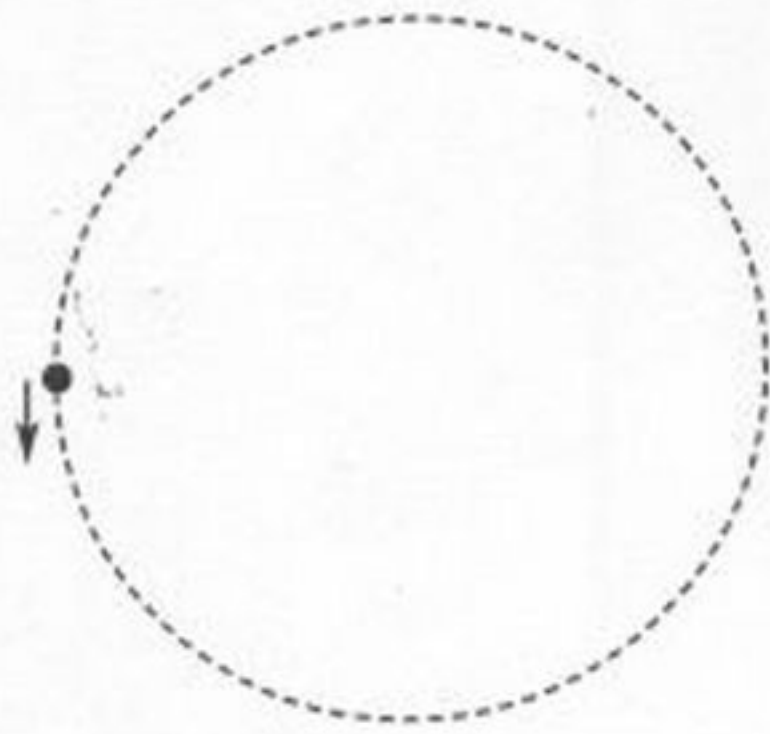

MARCA

las ruedas de la bicicleta siguiendo las flechas.

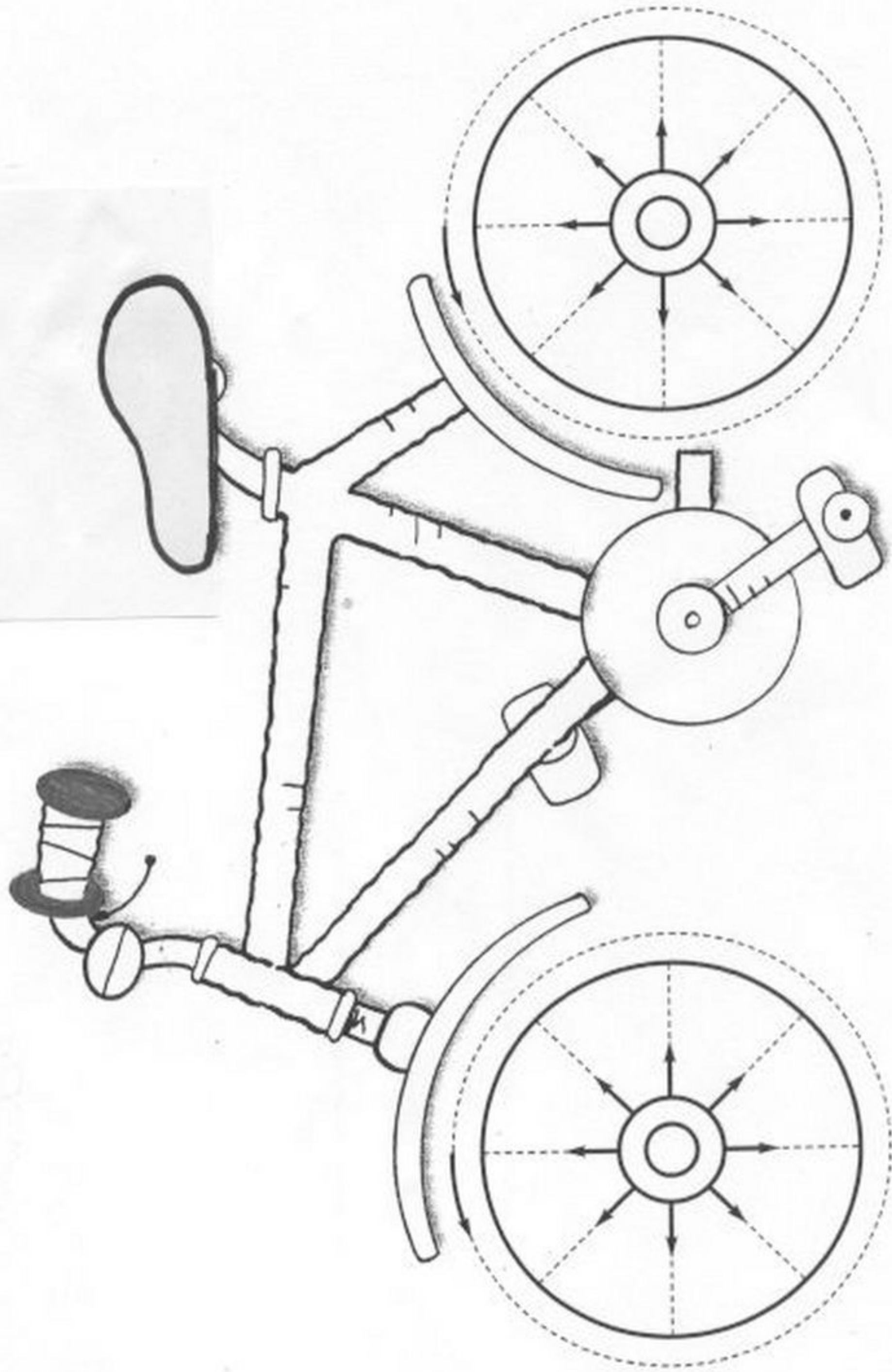

E.E.I. MAR DE ALBORÁN

Iniciación al punto. Reseguir los círculos.
• Colorear alrededor del punto hasta rellenarlo.

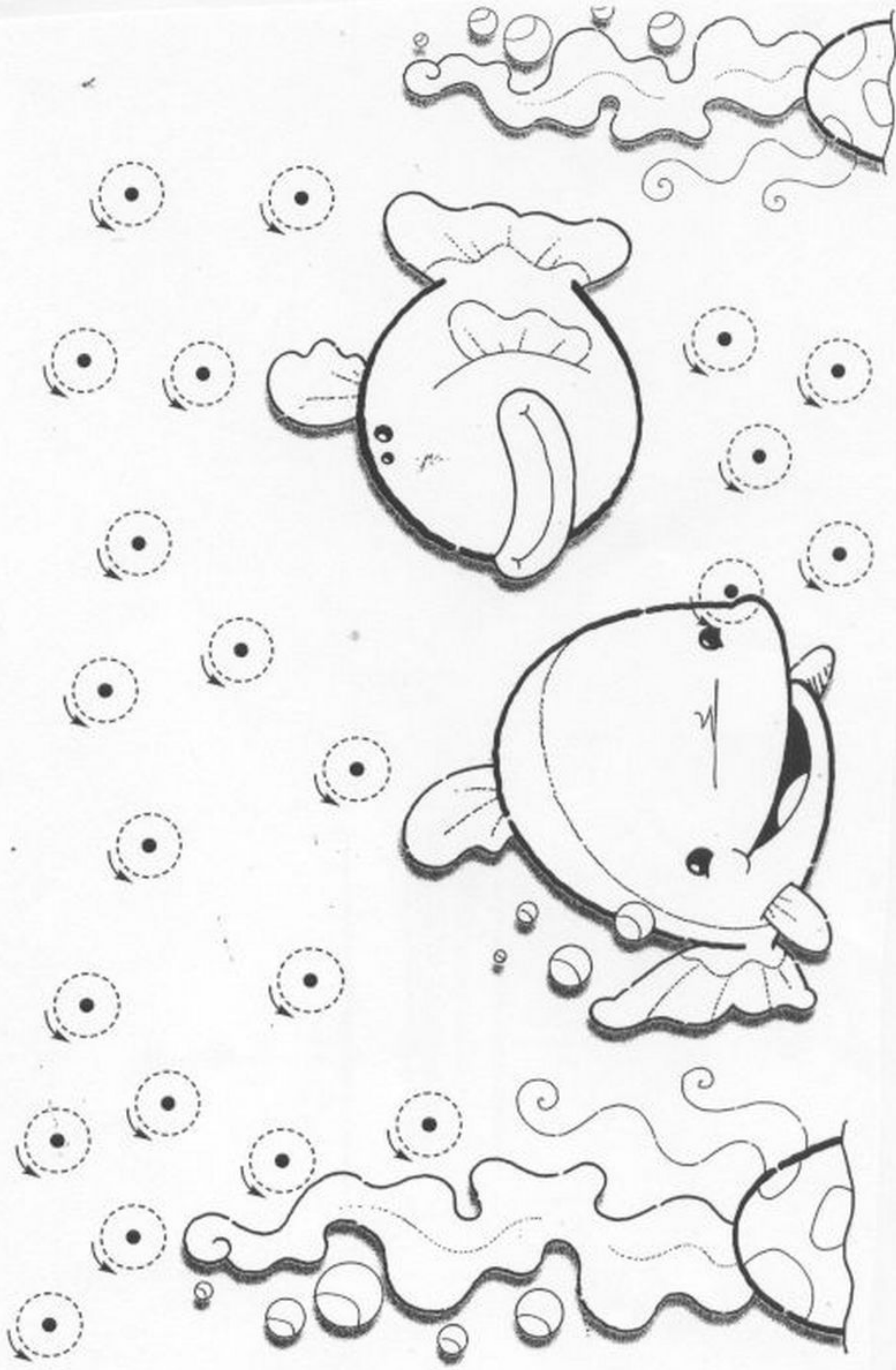



- Repasar con el dedo la forma del círculo.
- Realizar las grafías con rotulador.

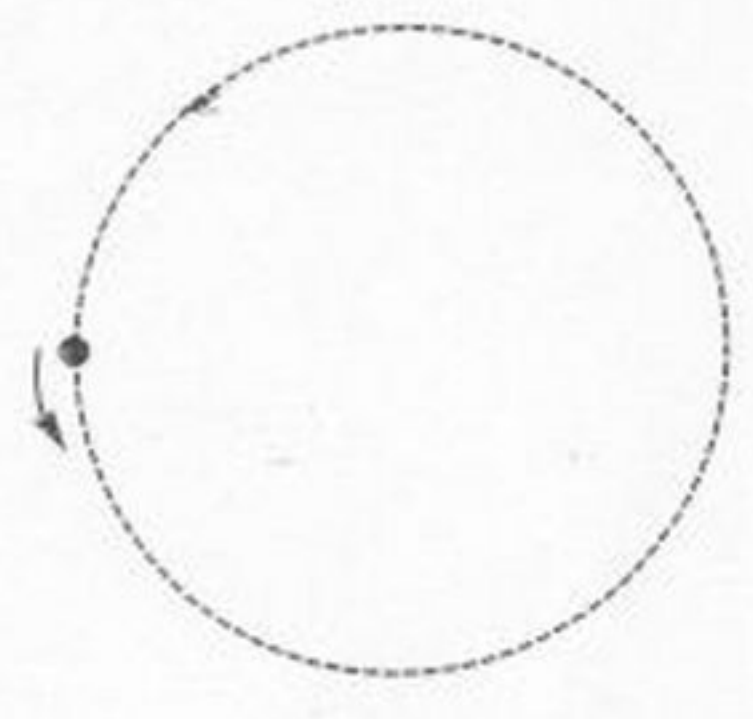



E.E.I. MAR DE ALBORÁN

DIBUJA

el globo siguiendo la dirección de la flecha

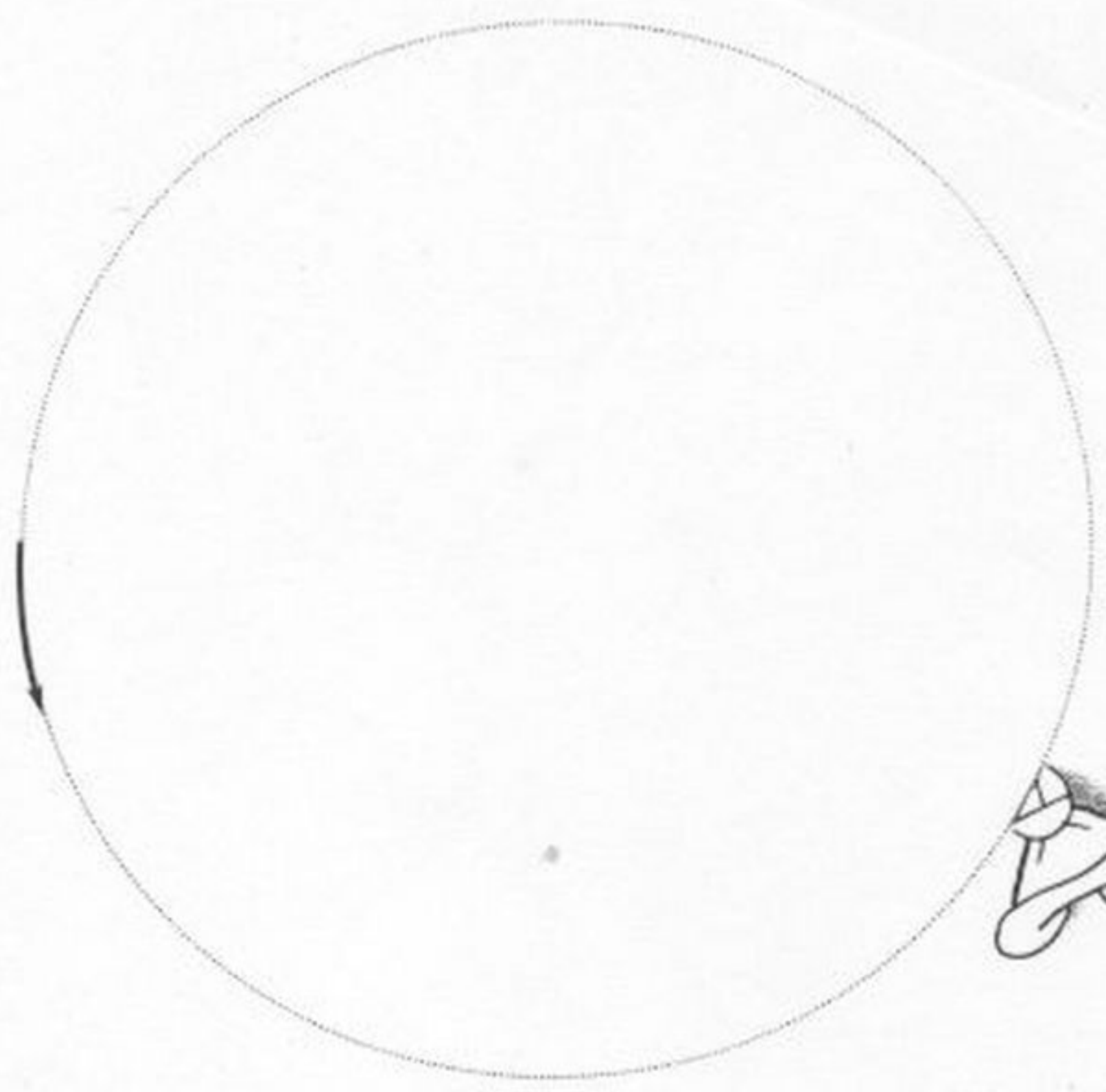

MARCA

con lápiz los trazos de línea discontinua siguiendo la dirección de las flechas.

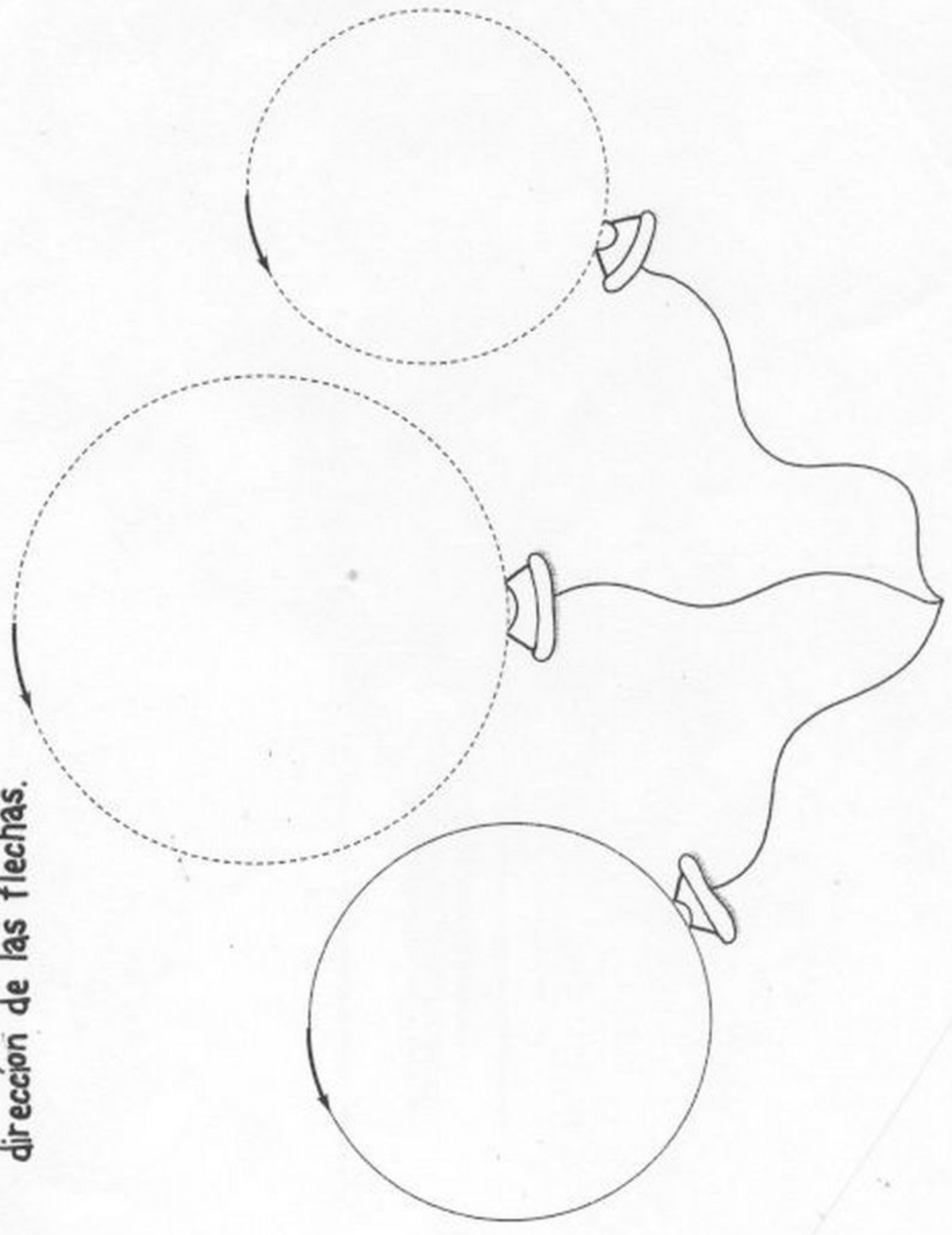



E.E.I. MAR DE ALBORÁN

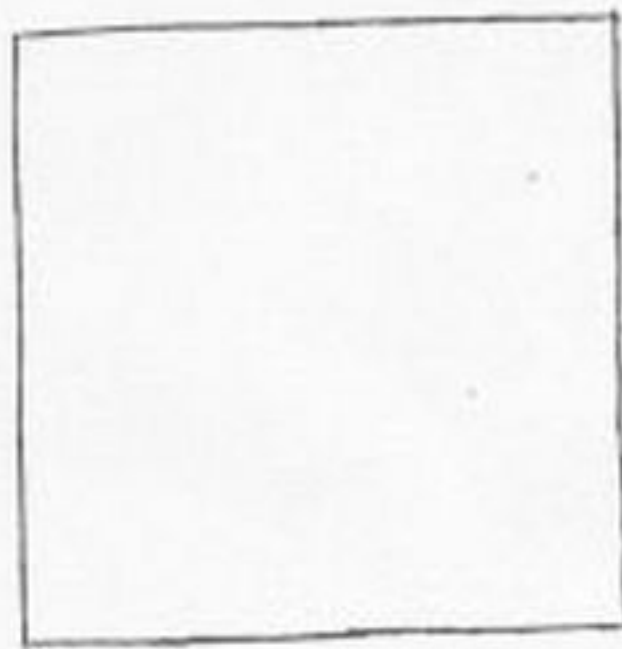
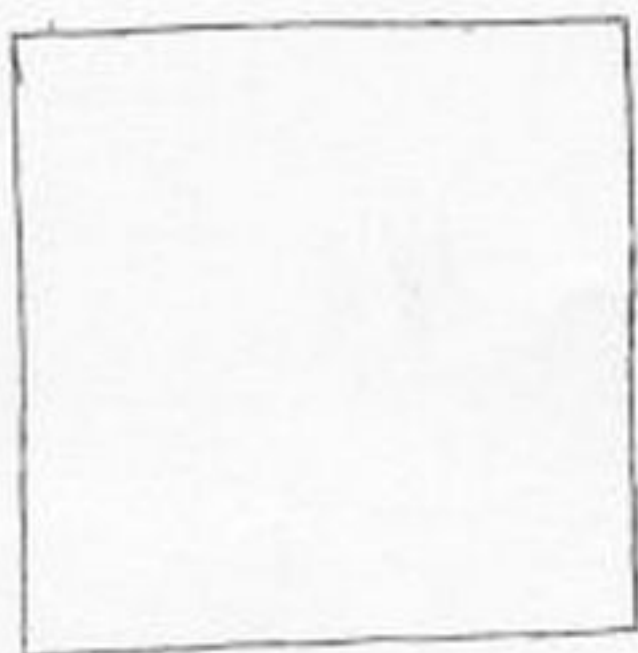
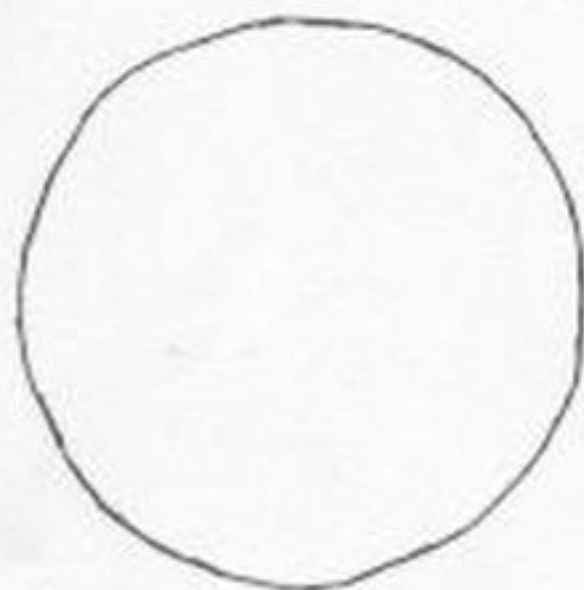
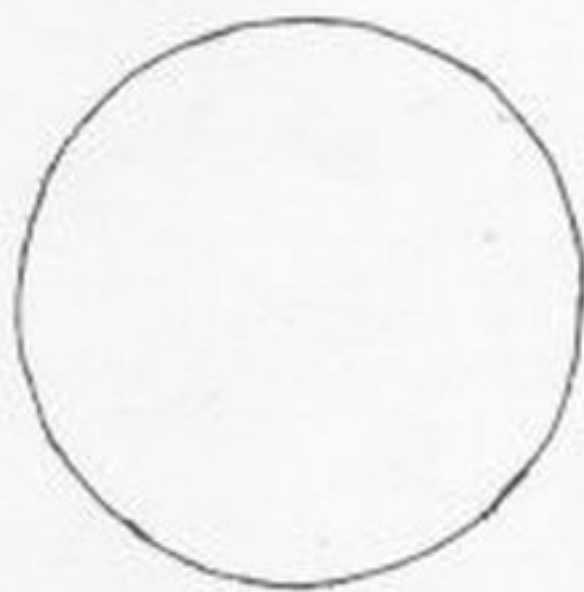
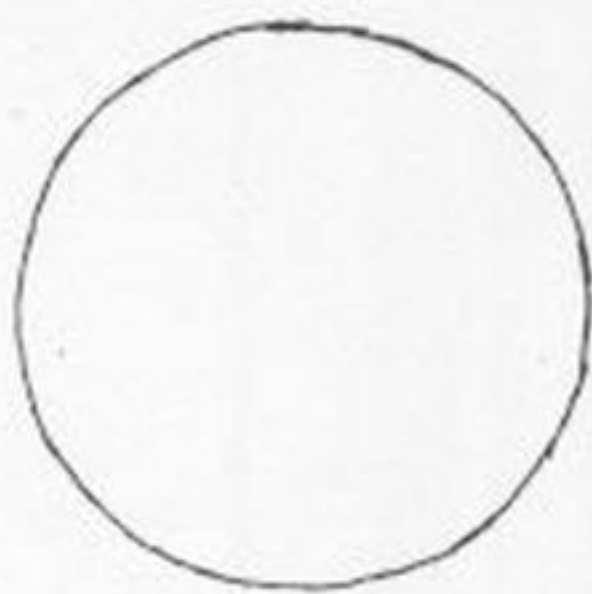
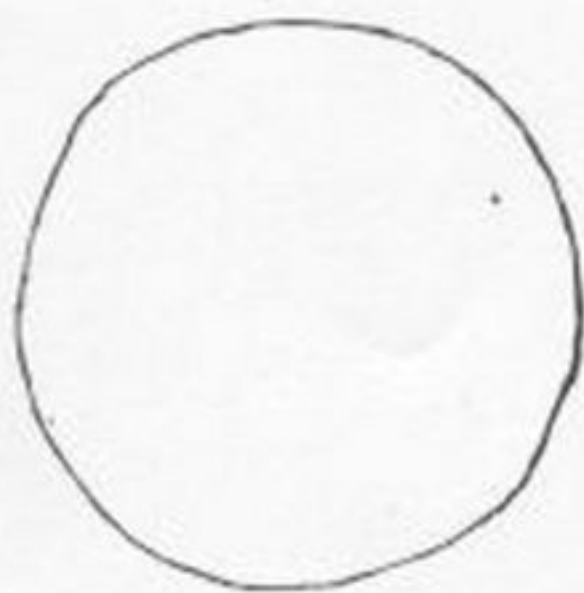
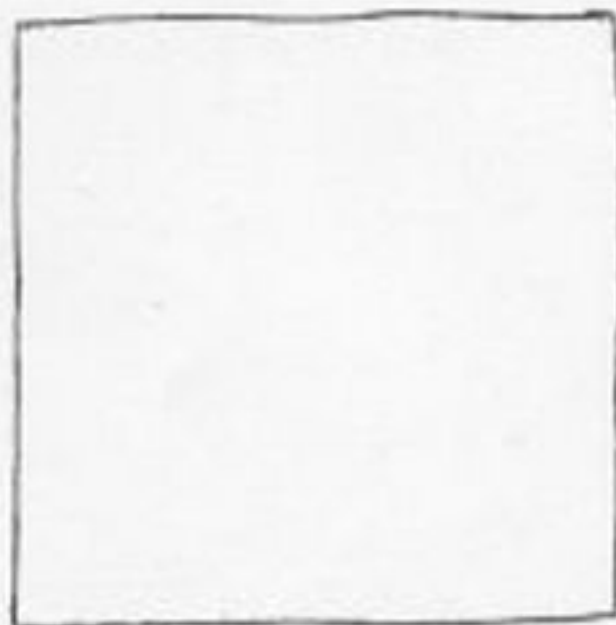
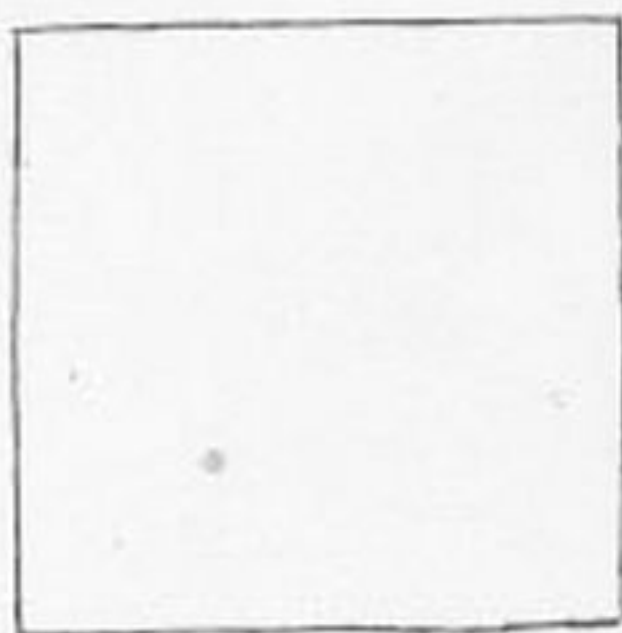
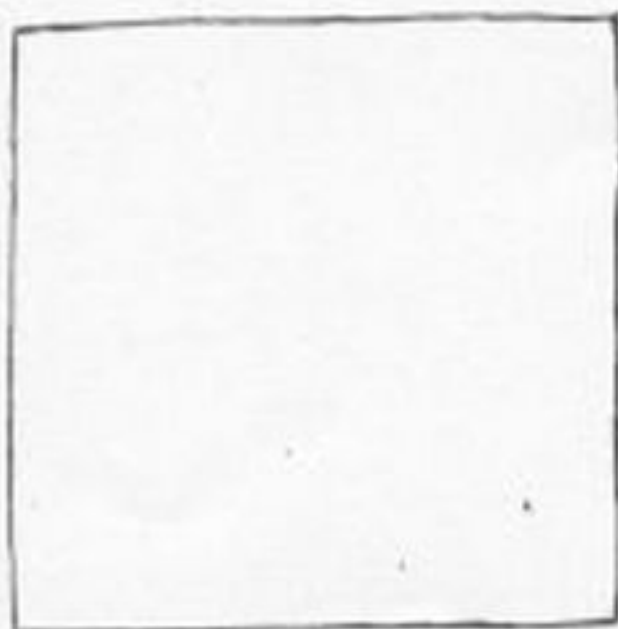
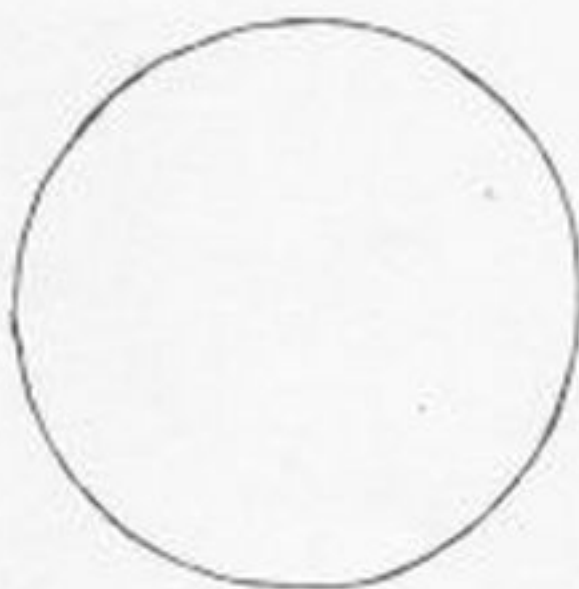
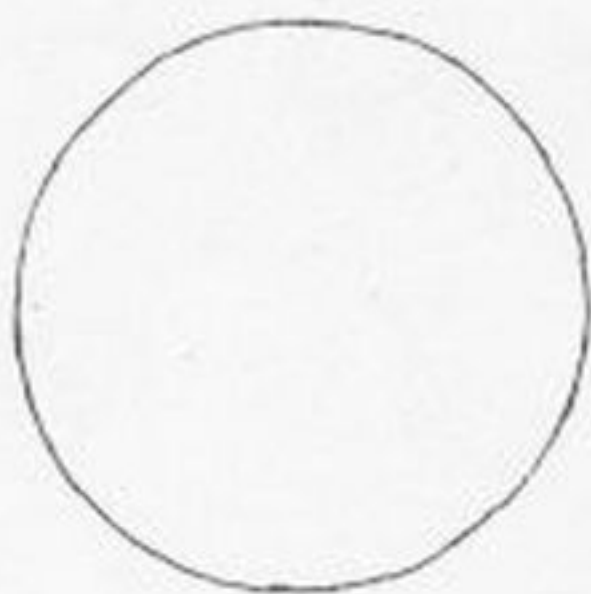
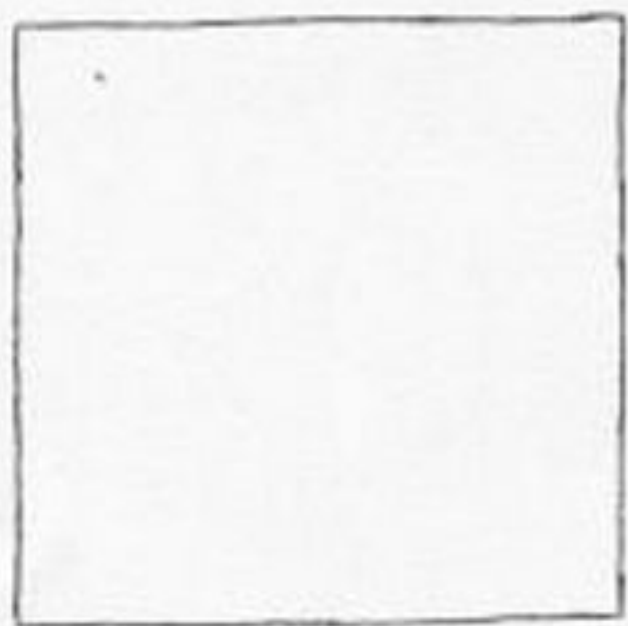



E.E.I. MAR DE ALBORÁN

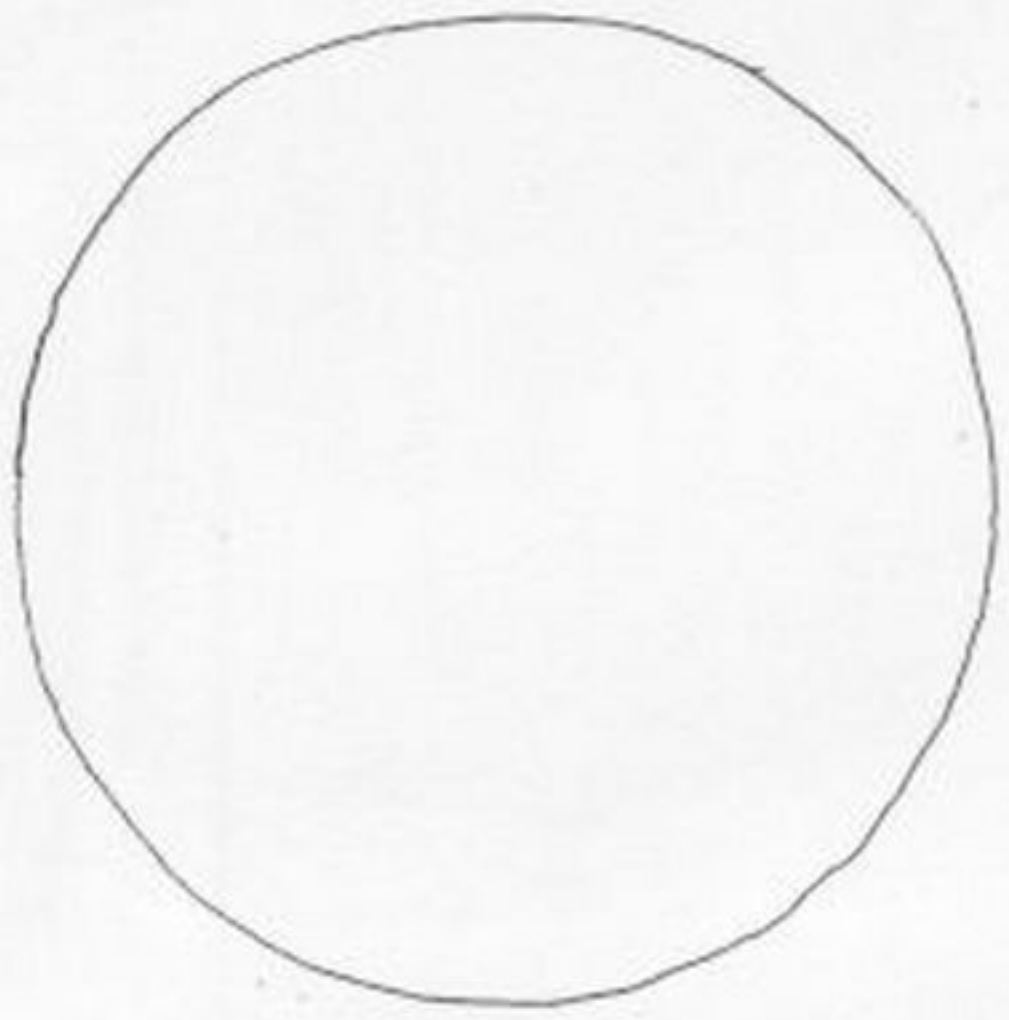
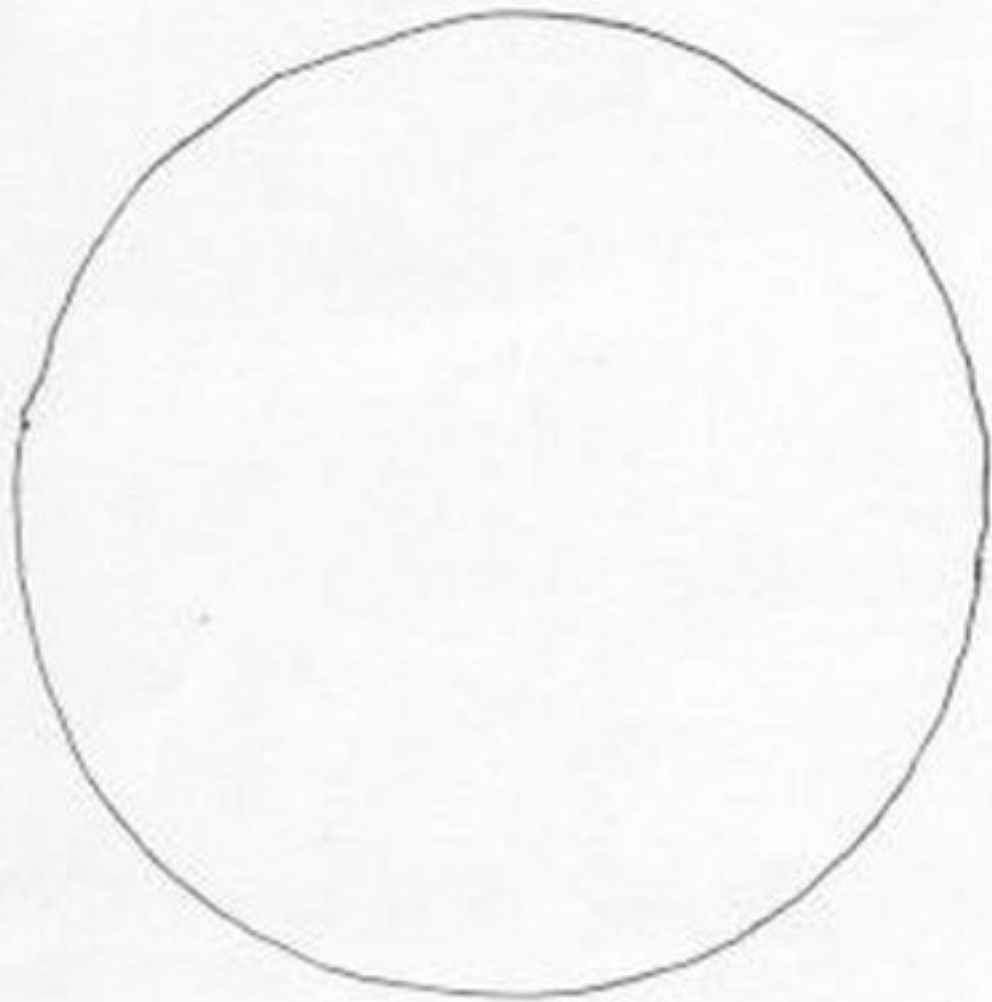
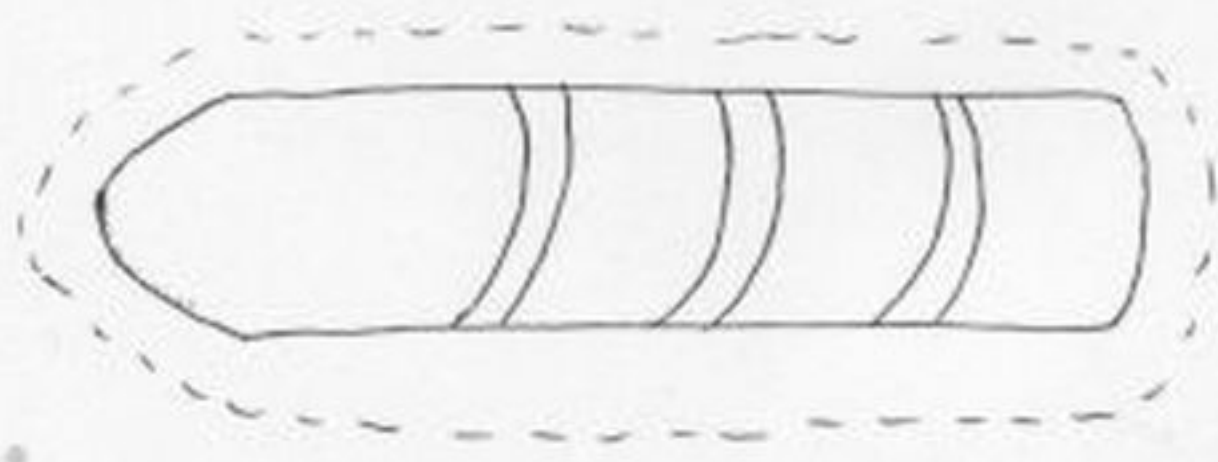
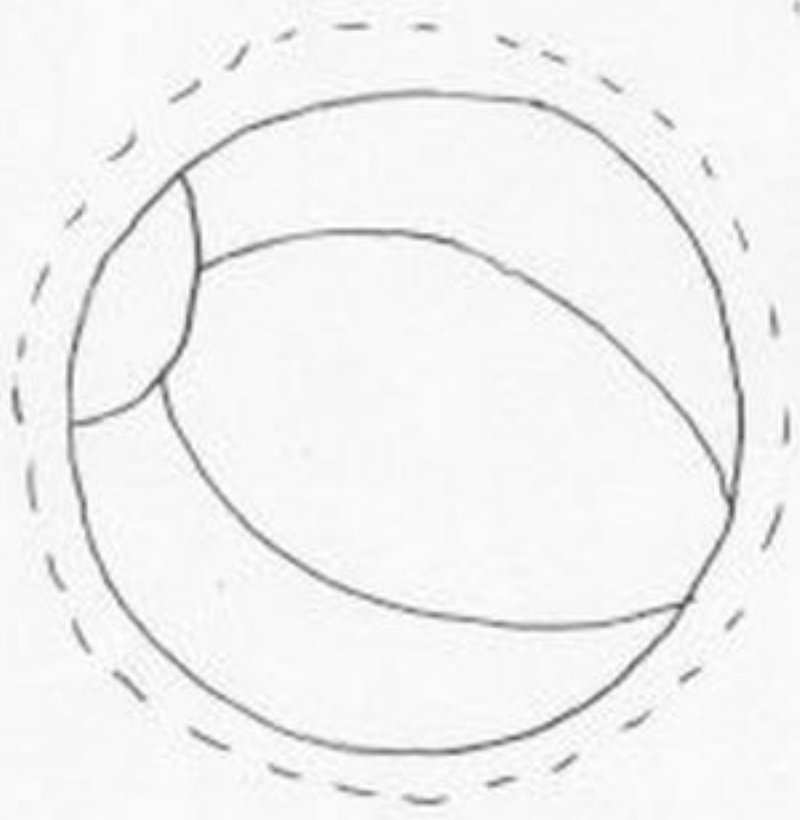



E.E.I. MAR DE ALBORÁN

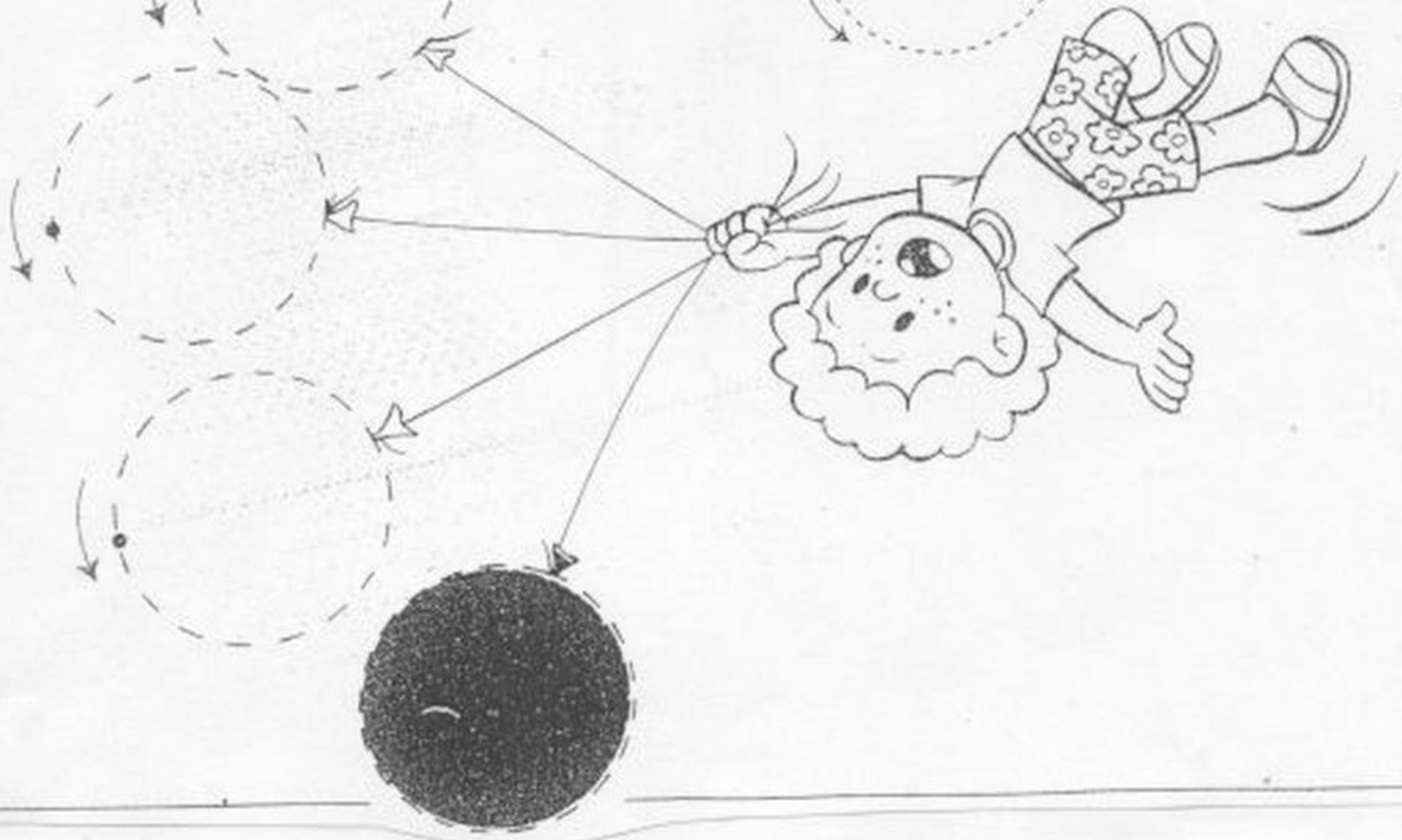
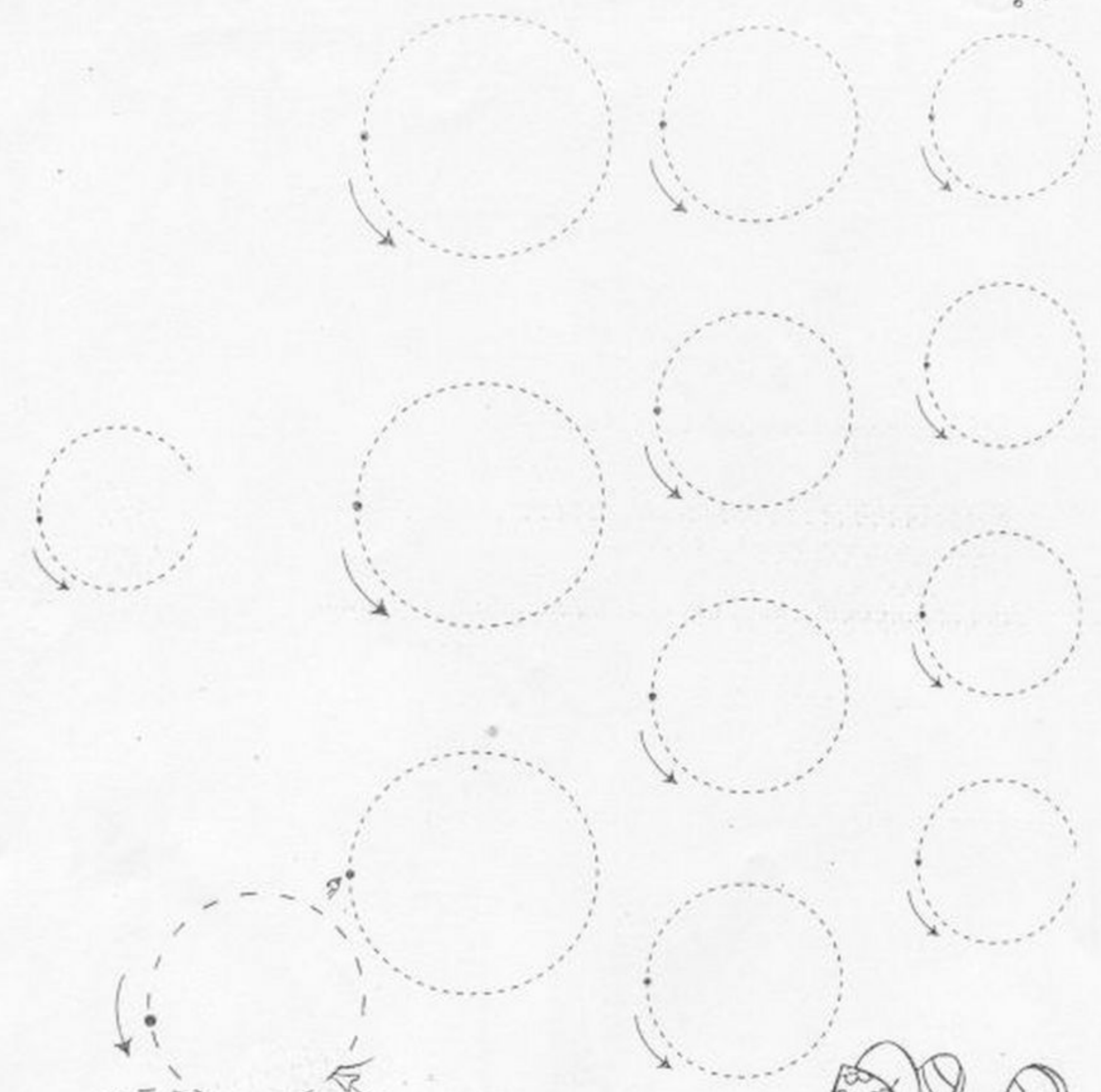

- *Reseguir* las grafías siguiendo las indicaciones de la flecha.
- Utilizar un instrumento de punta fina (rotulador, lápiz).

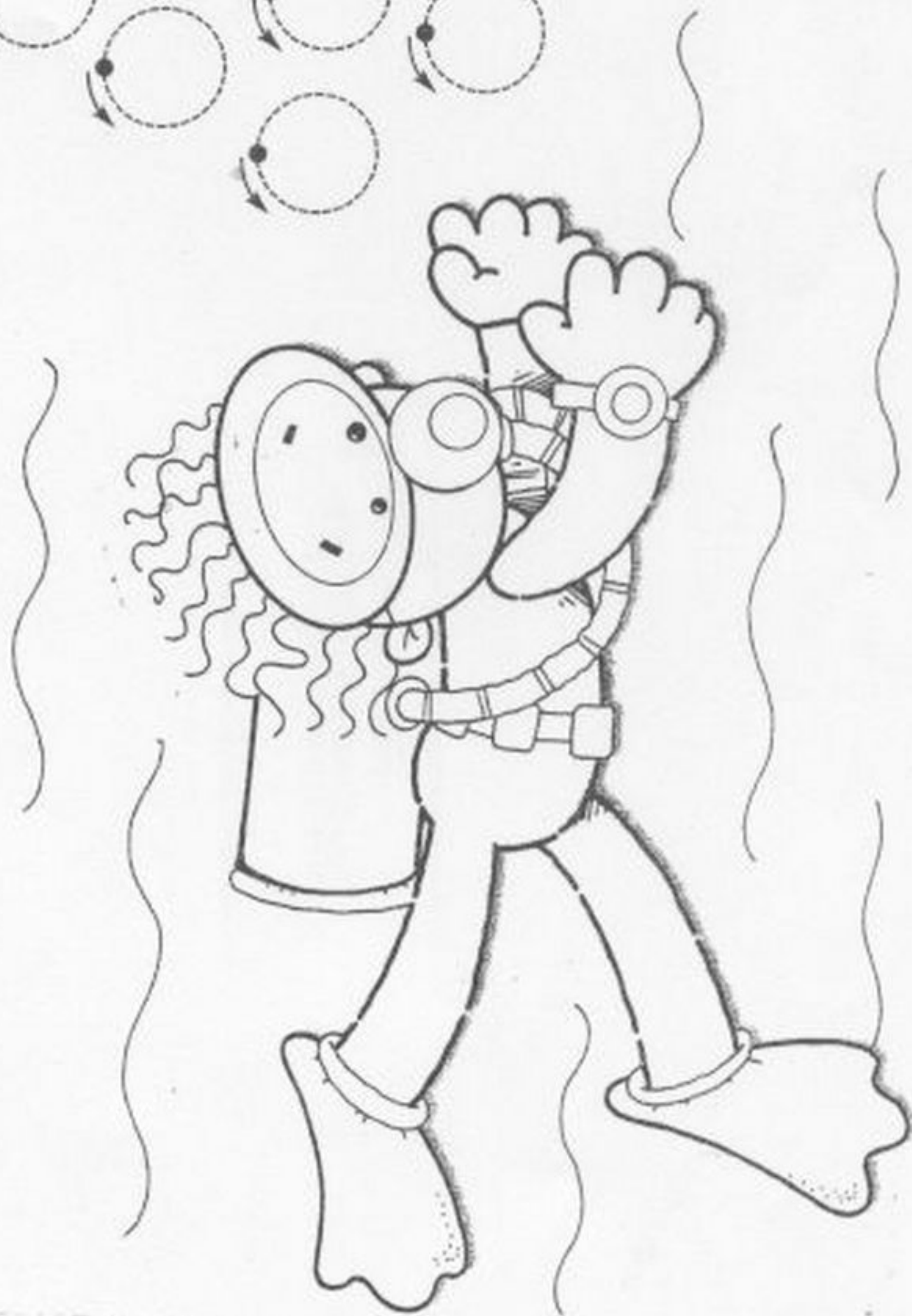
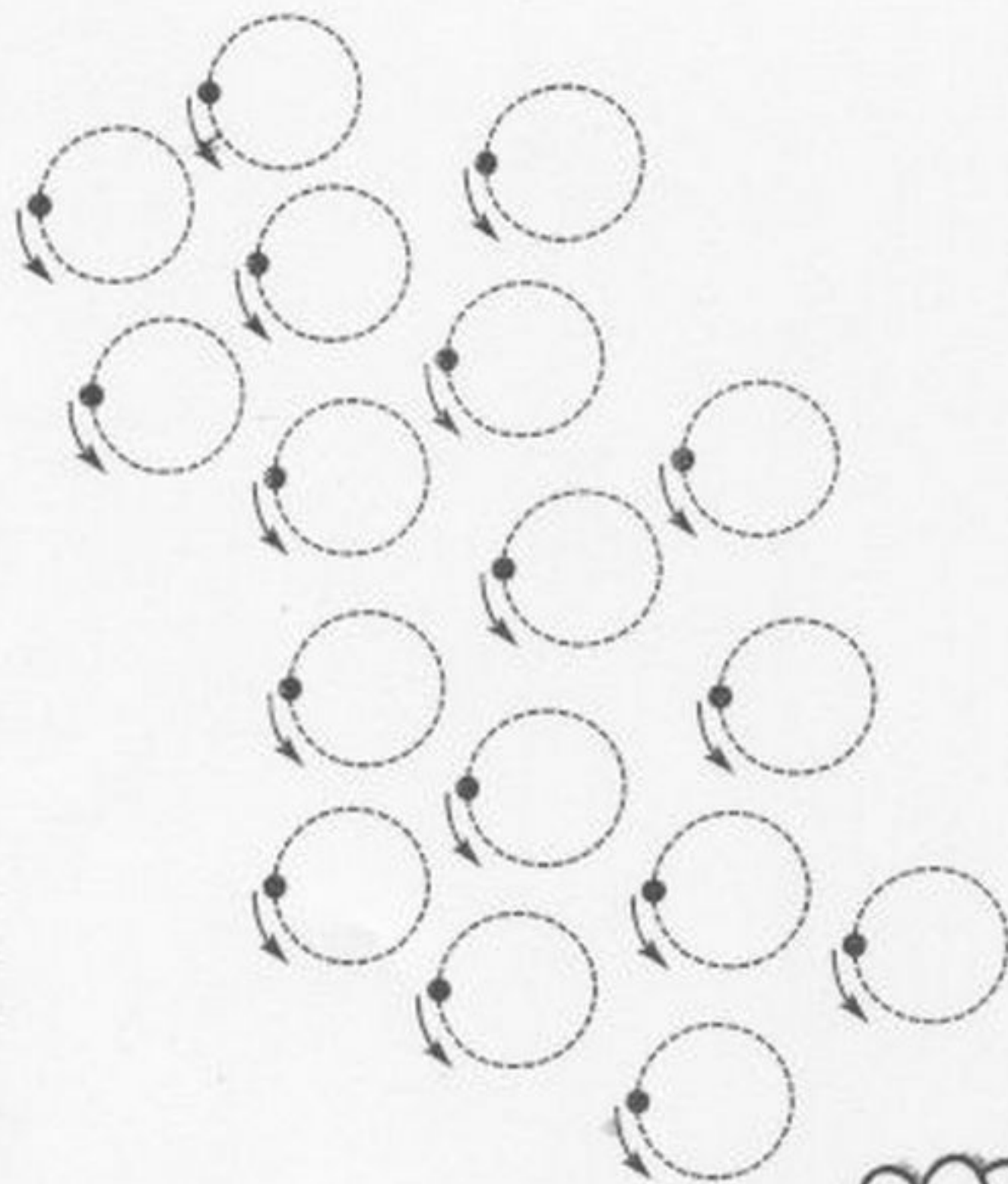

DENTRO - FUERA

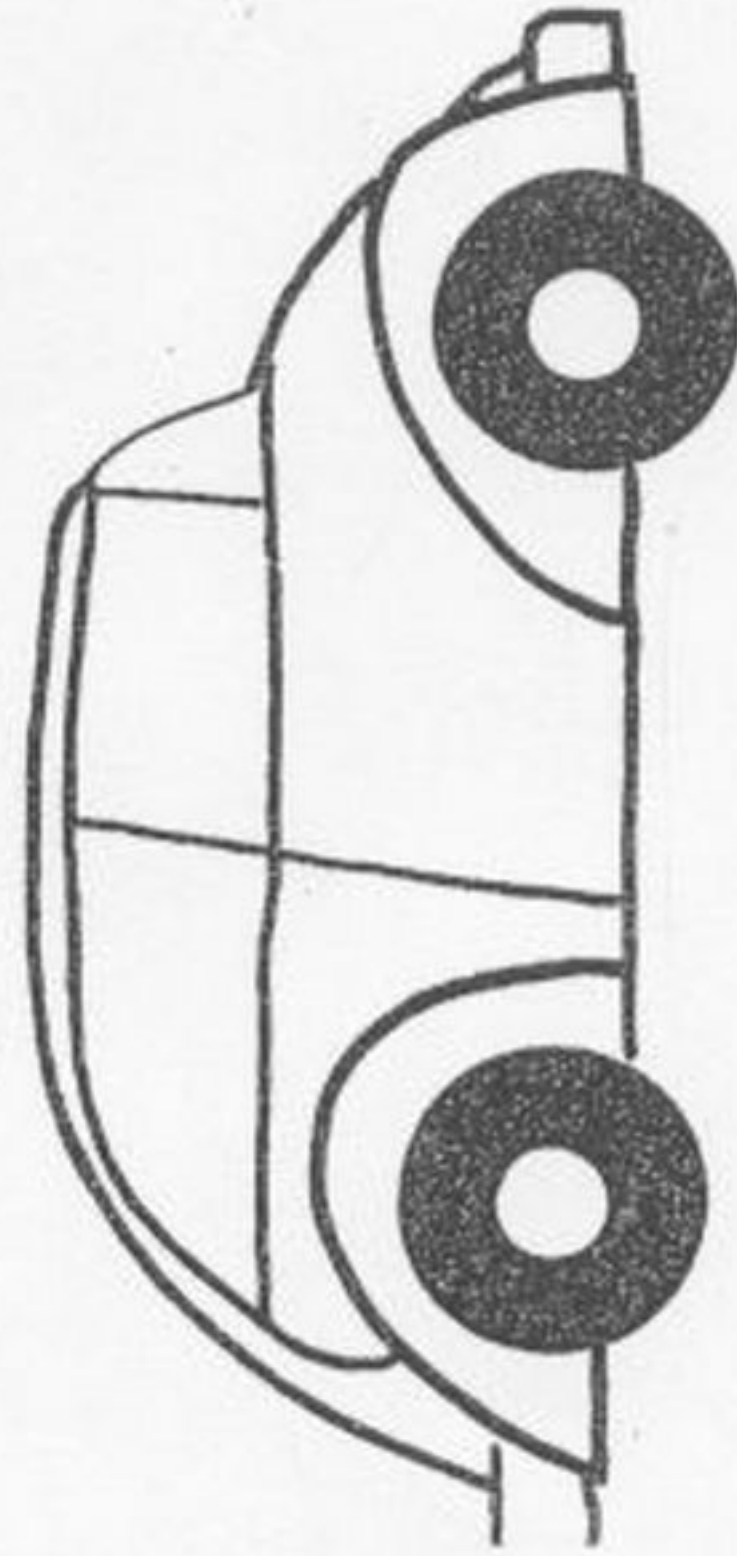
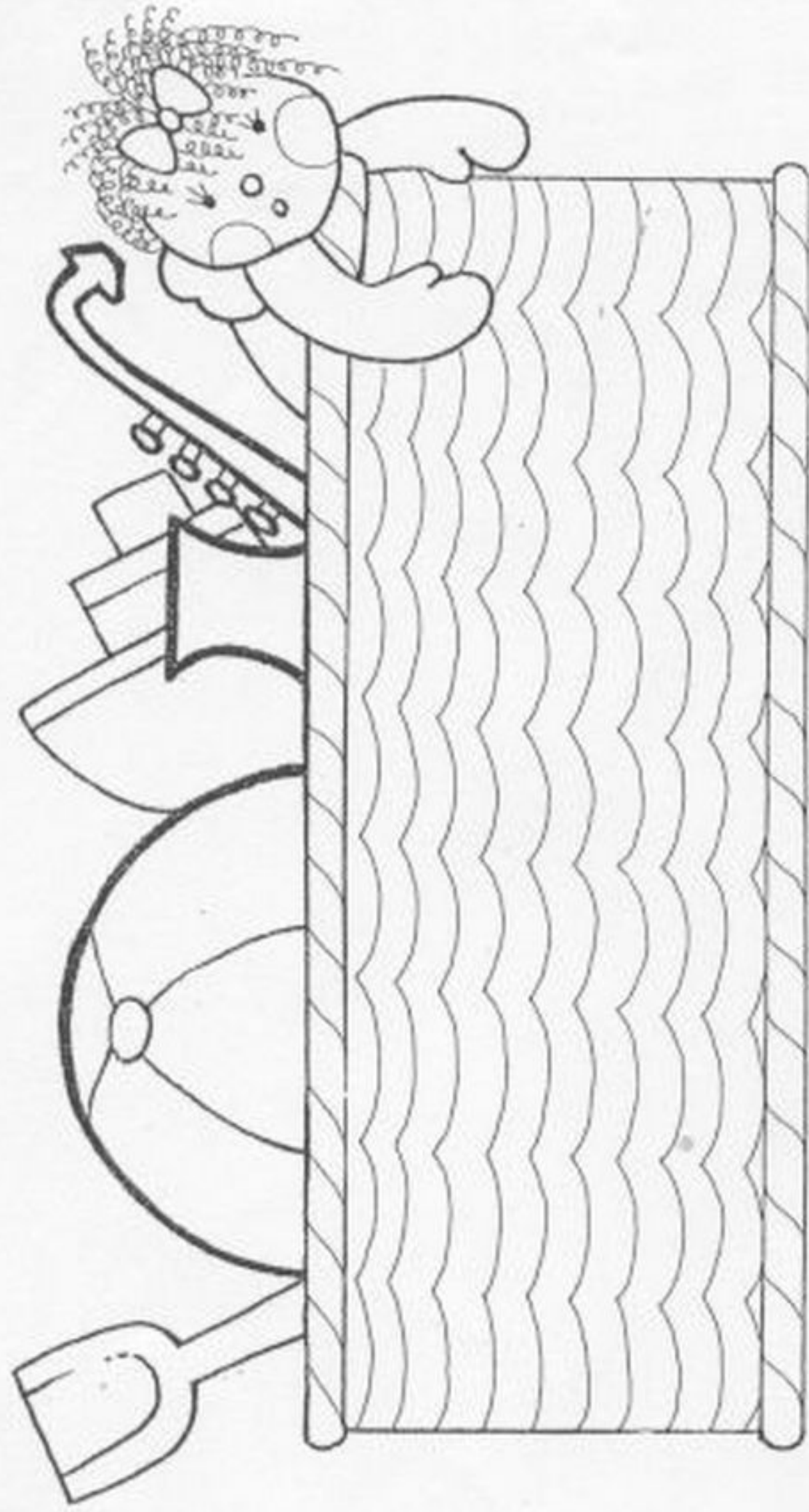
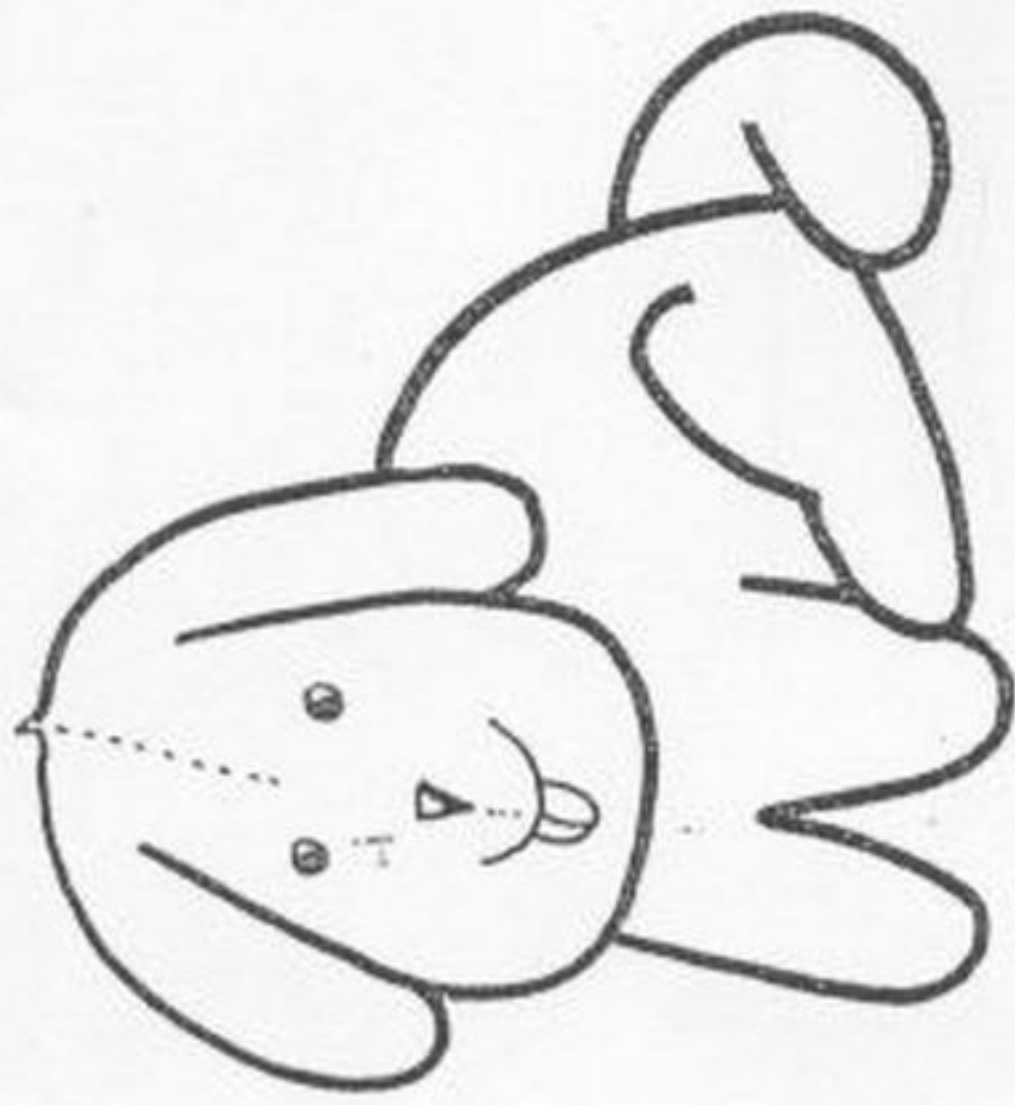

Colorear los juguetes que están fuera.



E.E.I. MAR DE ALBORÁN



E.E.I. MAR DE ALBORÁN

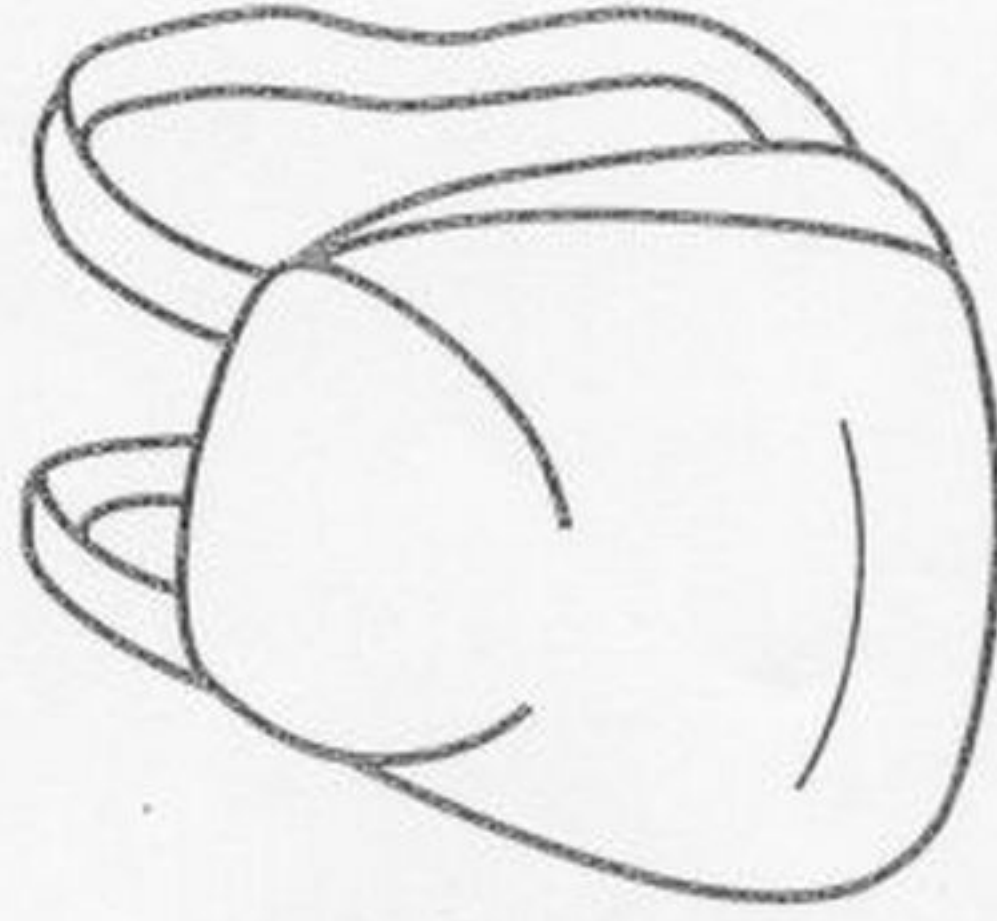
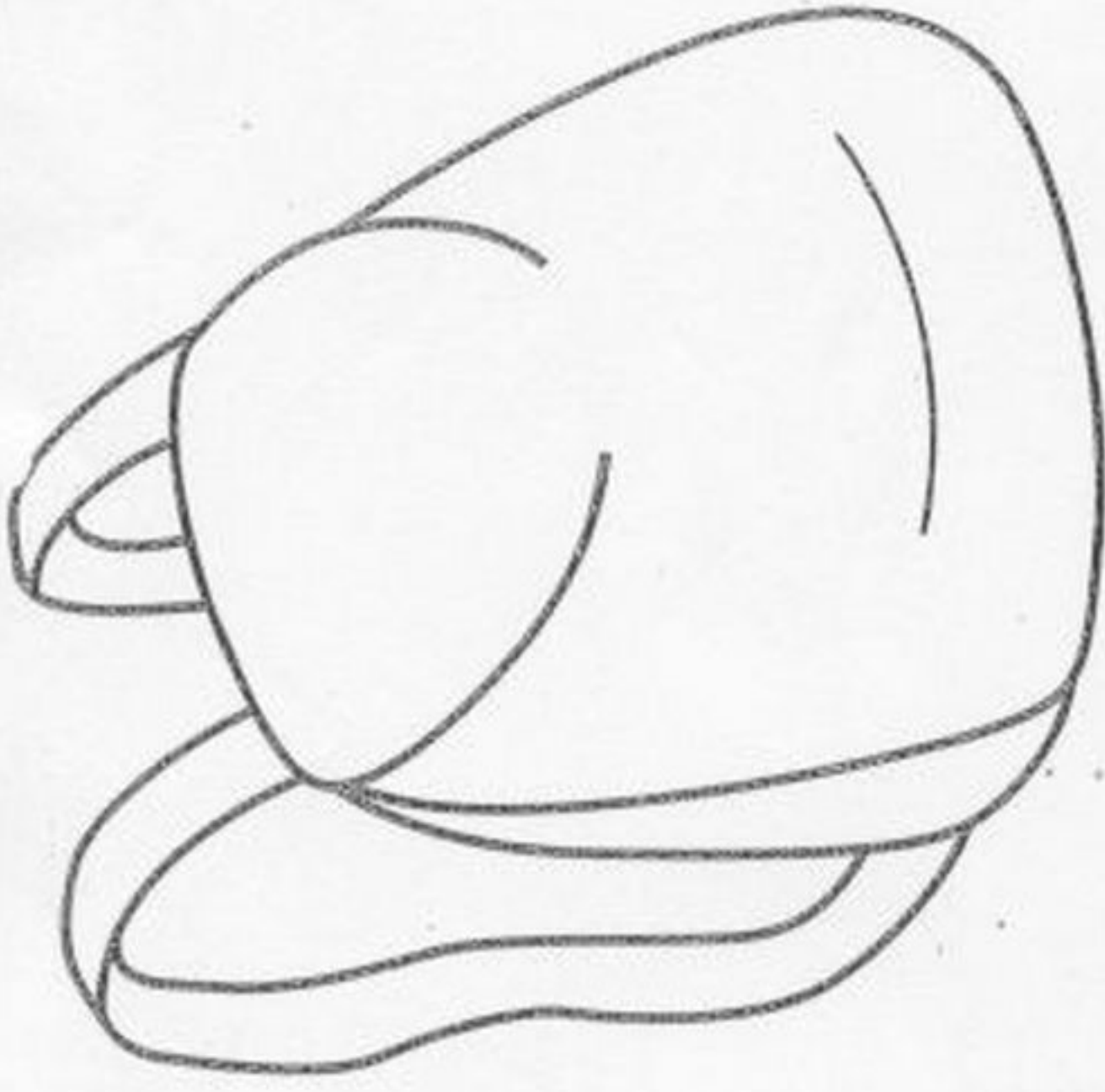

GRANDE-PEQUEÑO

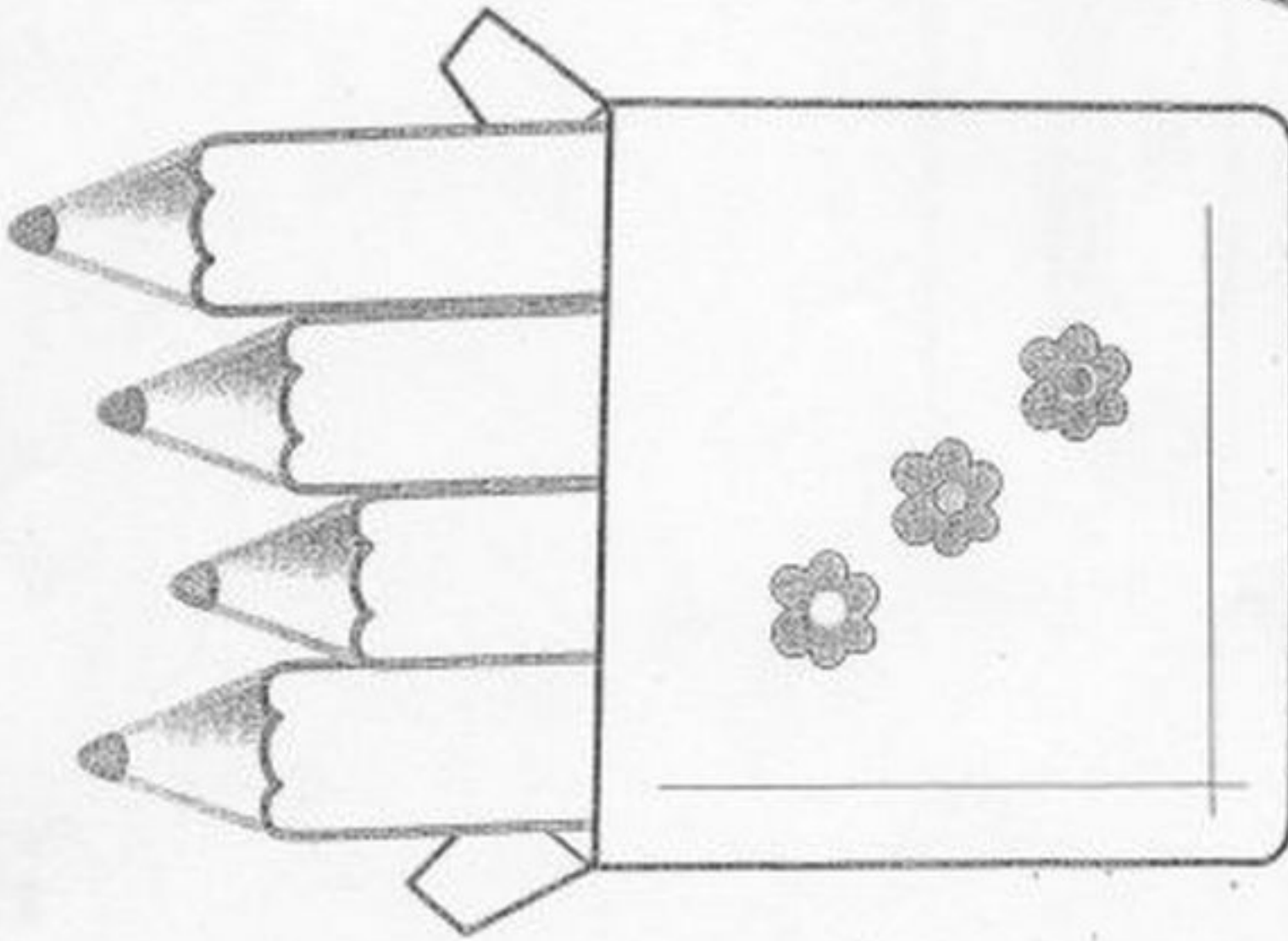
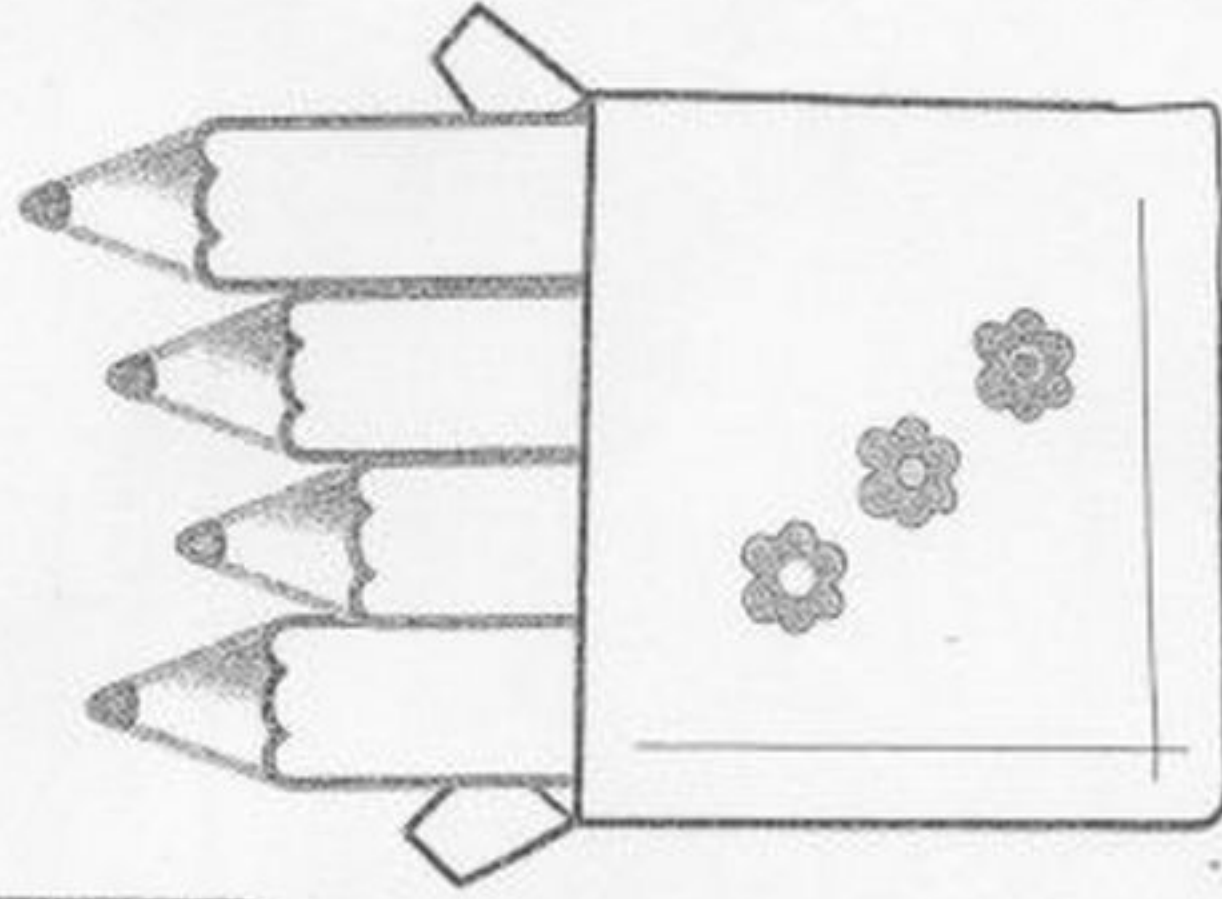



E.E.I. MAR DE ALBORÁN

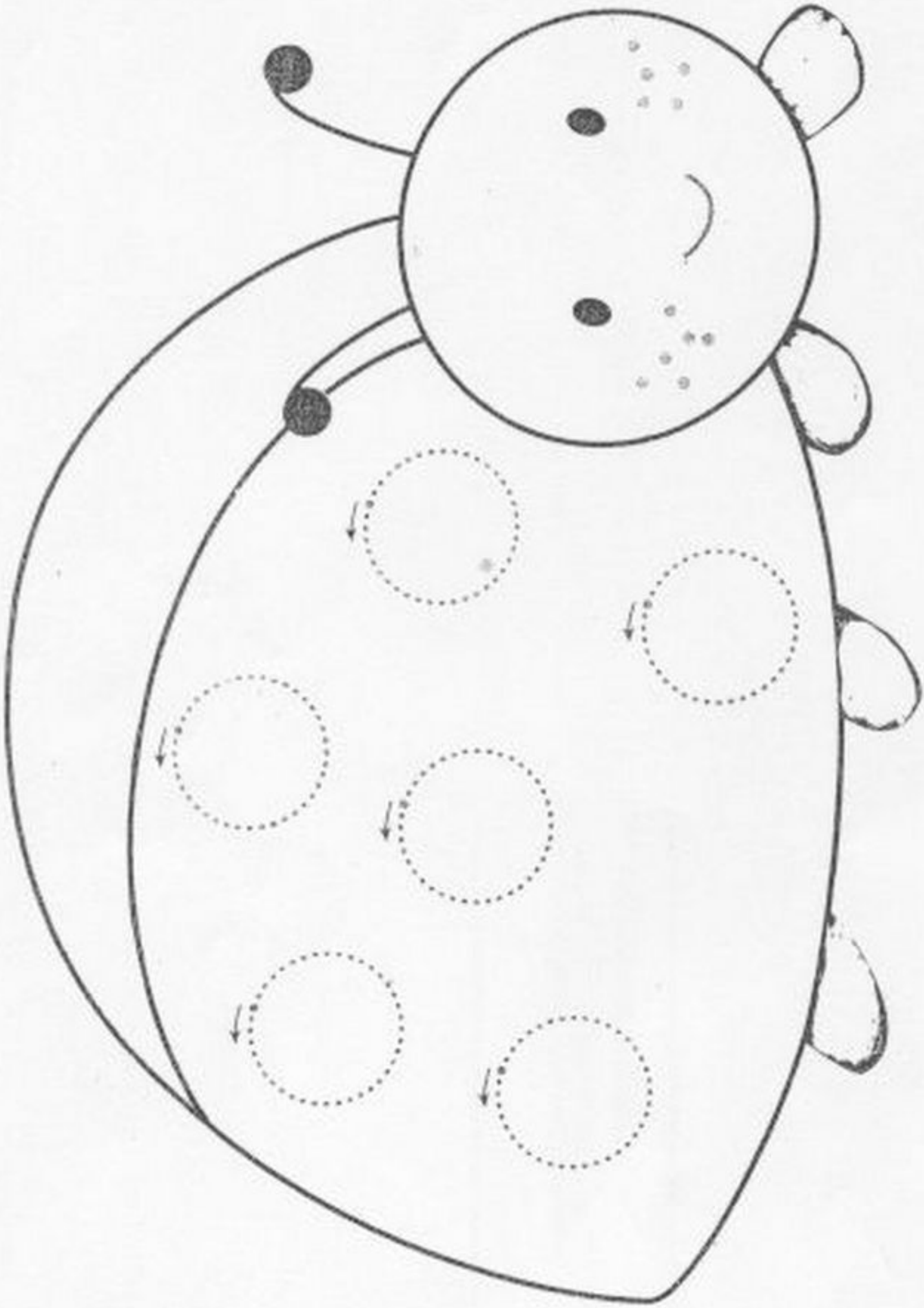



E.E.I. MAR DE ALBORÁN

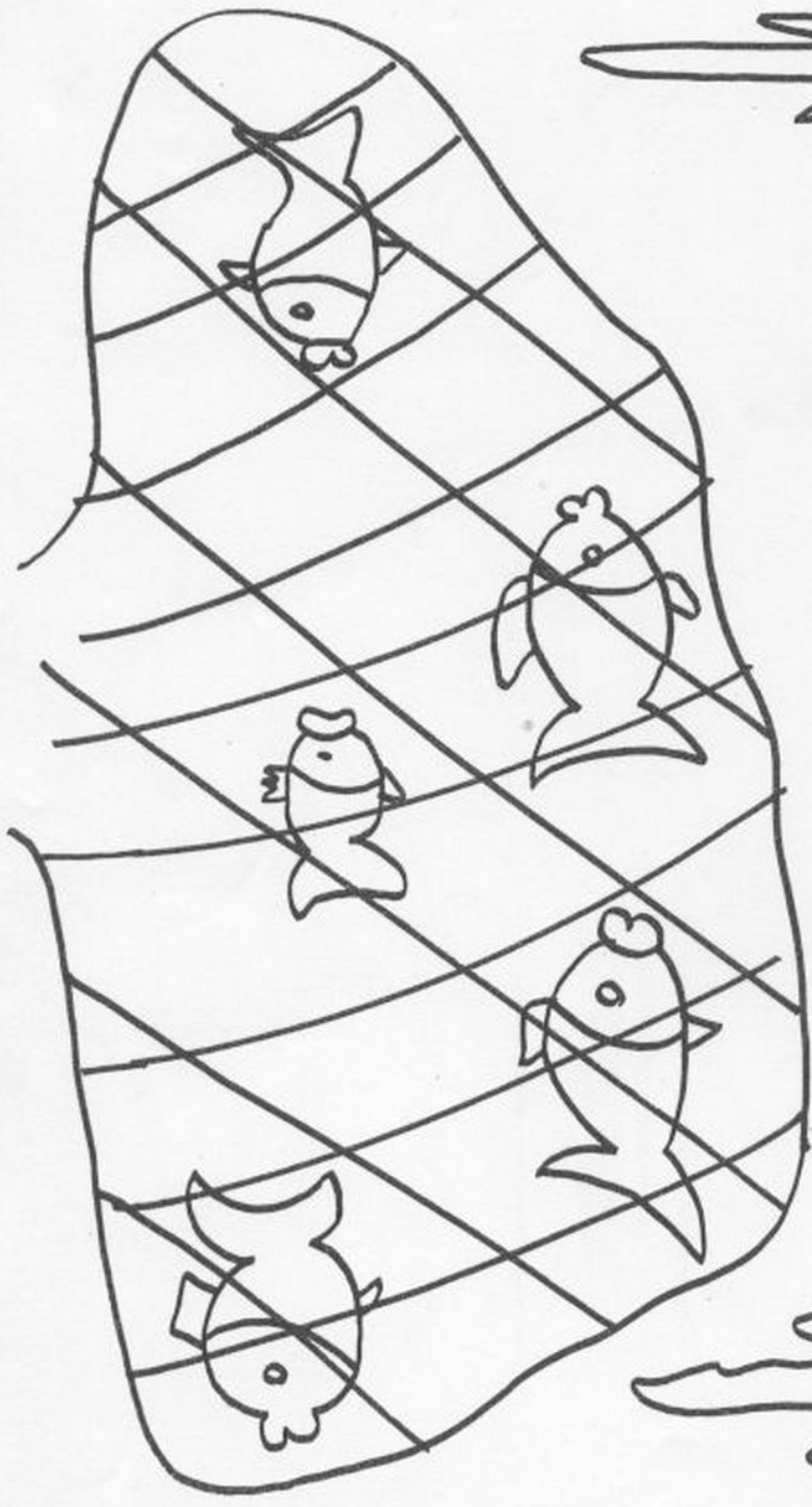
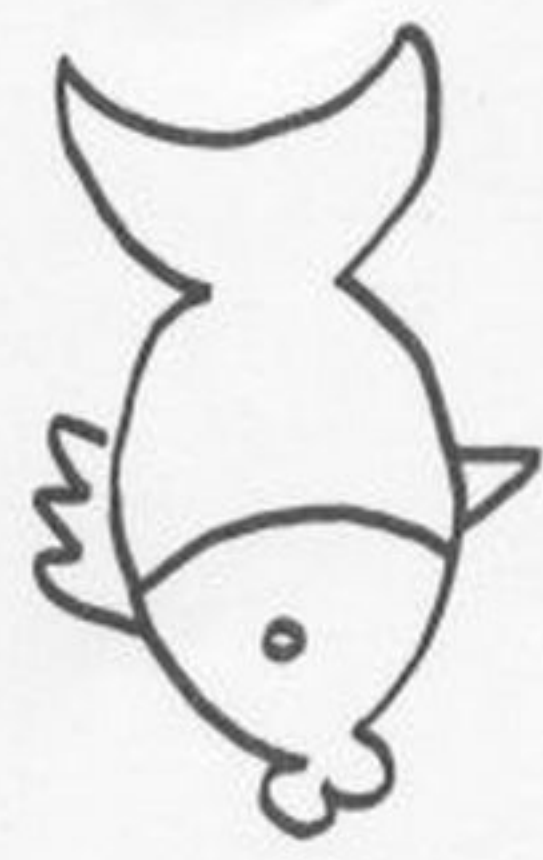
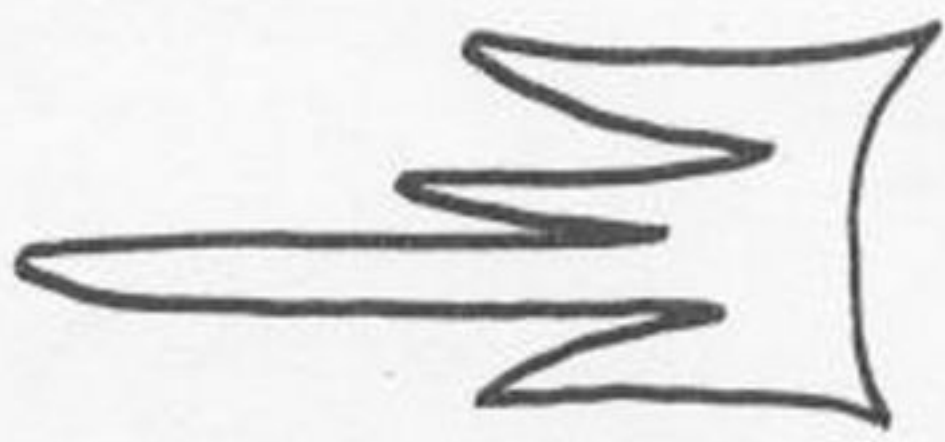



E.E.I. MAR DE ALBORÁN

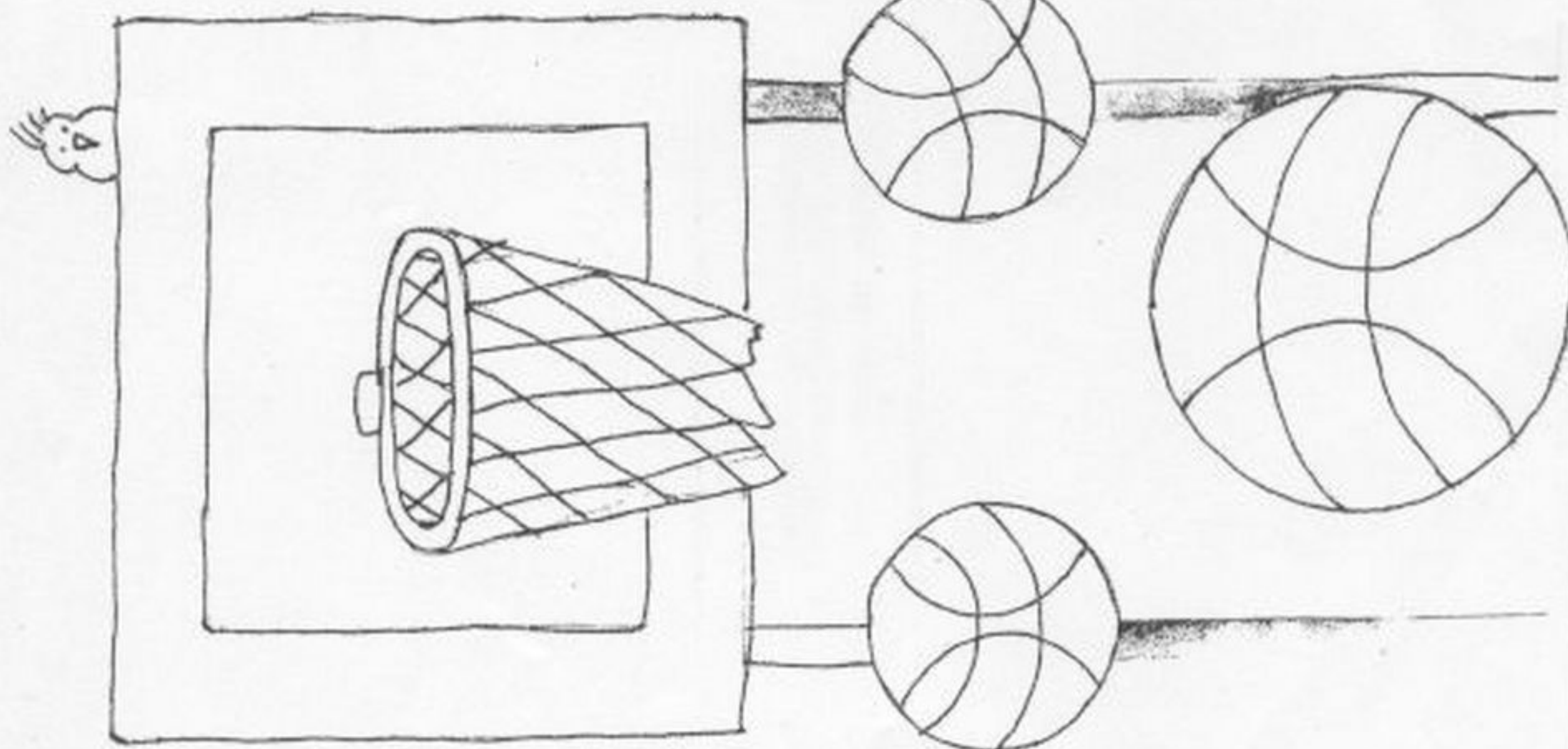
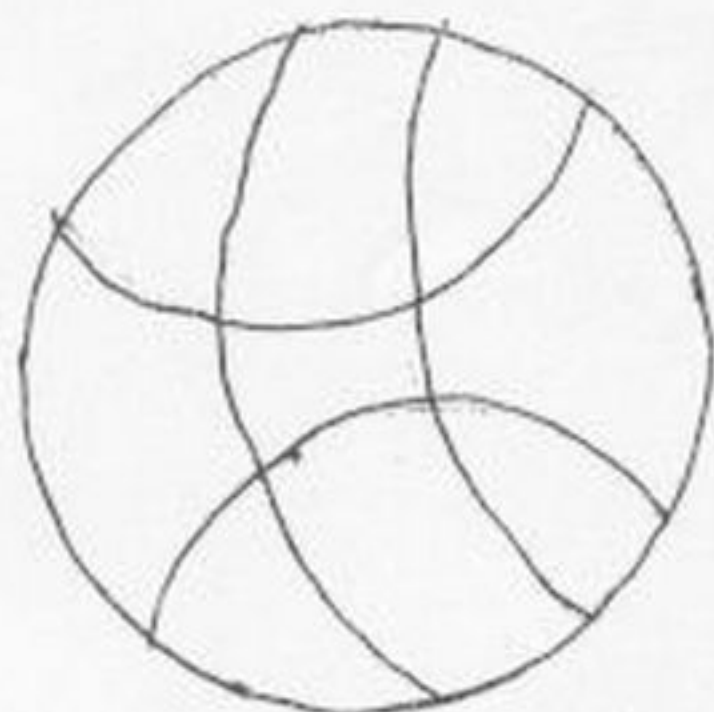



E.E.I. MAR DE ALBORÁN

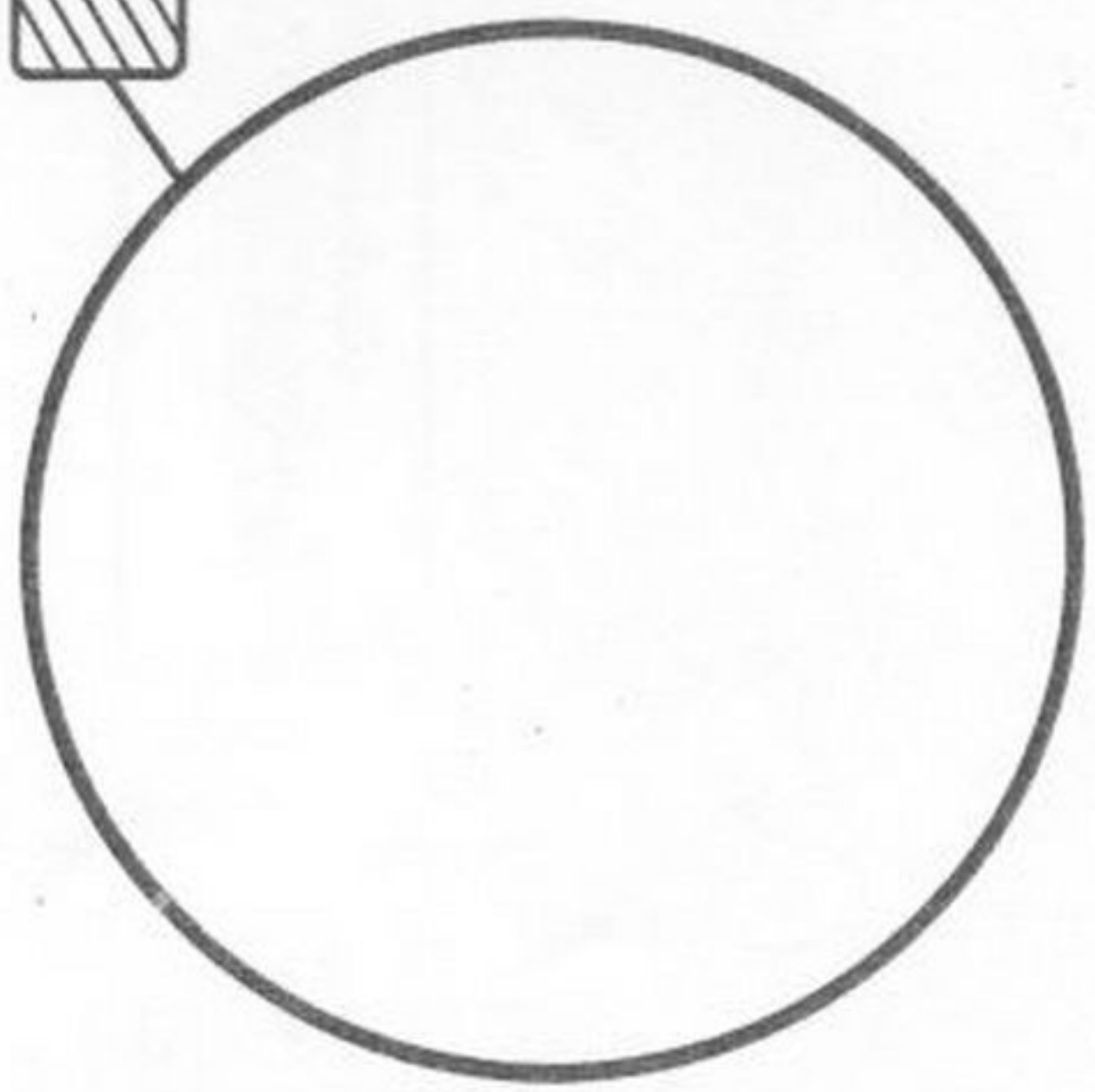
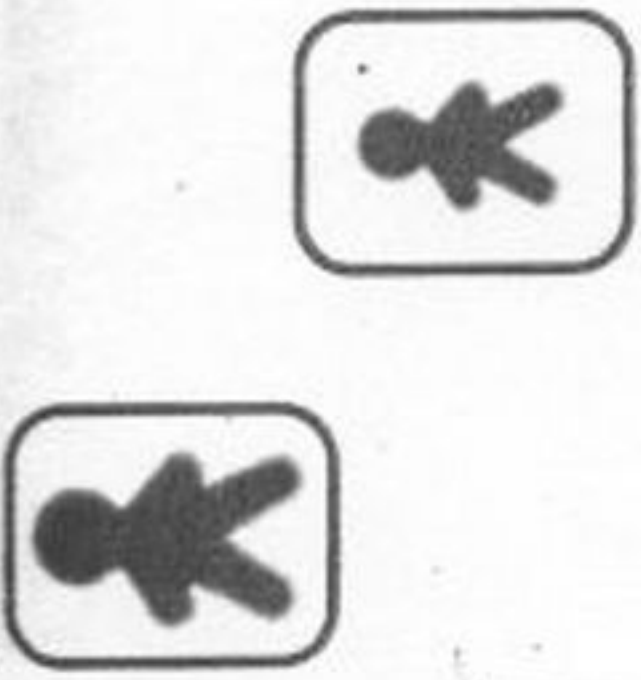
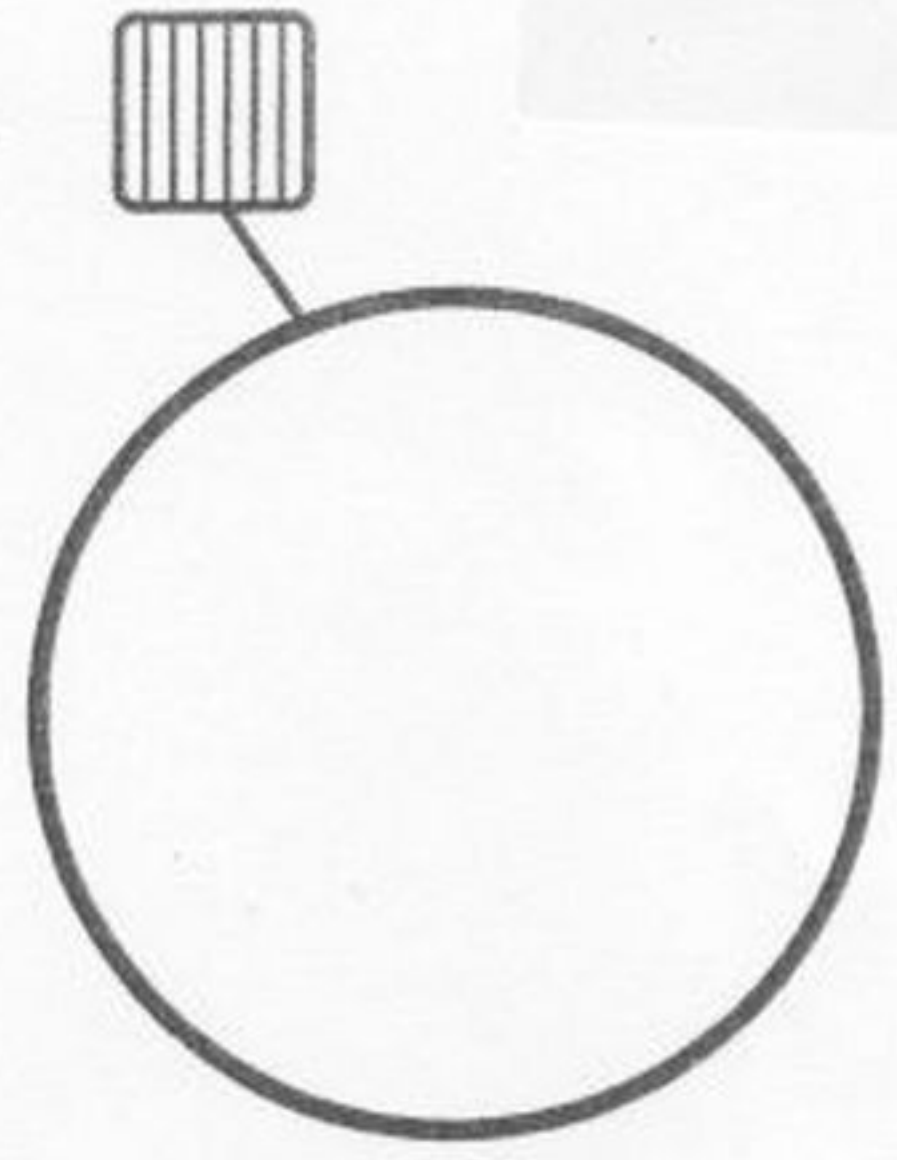
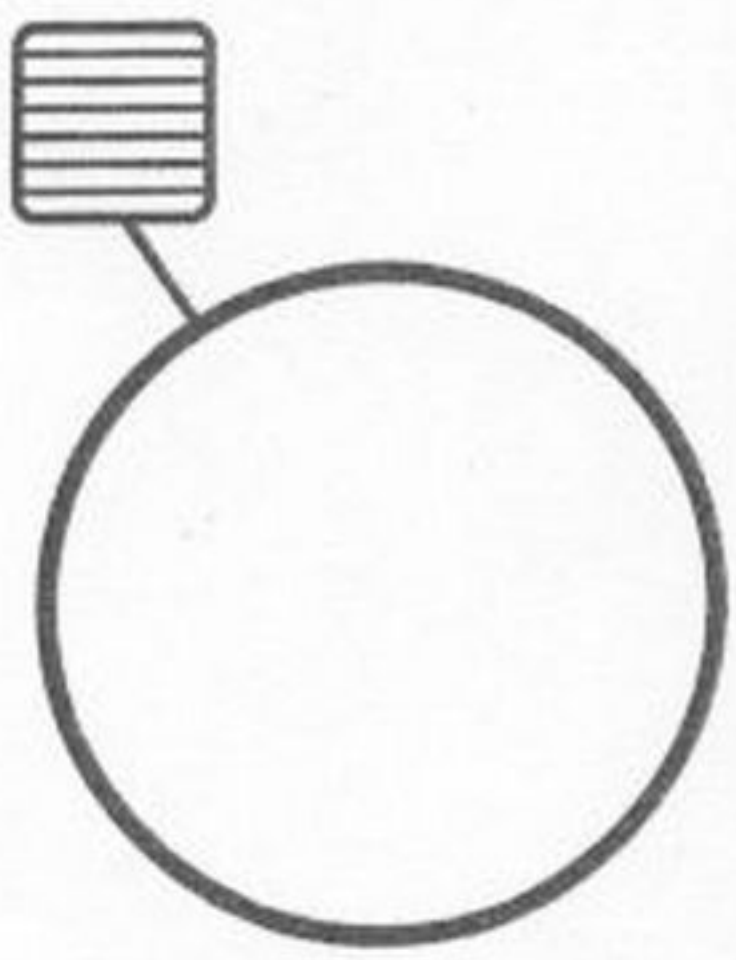

Unir cada figura con su etiqueta de tamaño y decorar según los códigos.

• *Hacer* las grafías con cera gruesa siguiendo la dirección de las flechas.

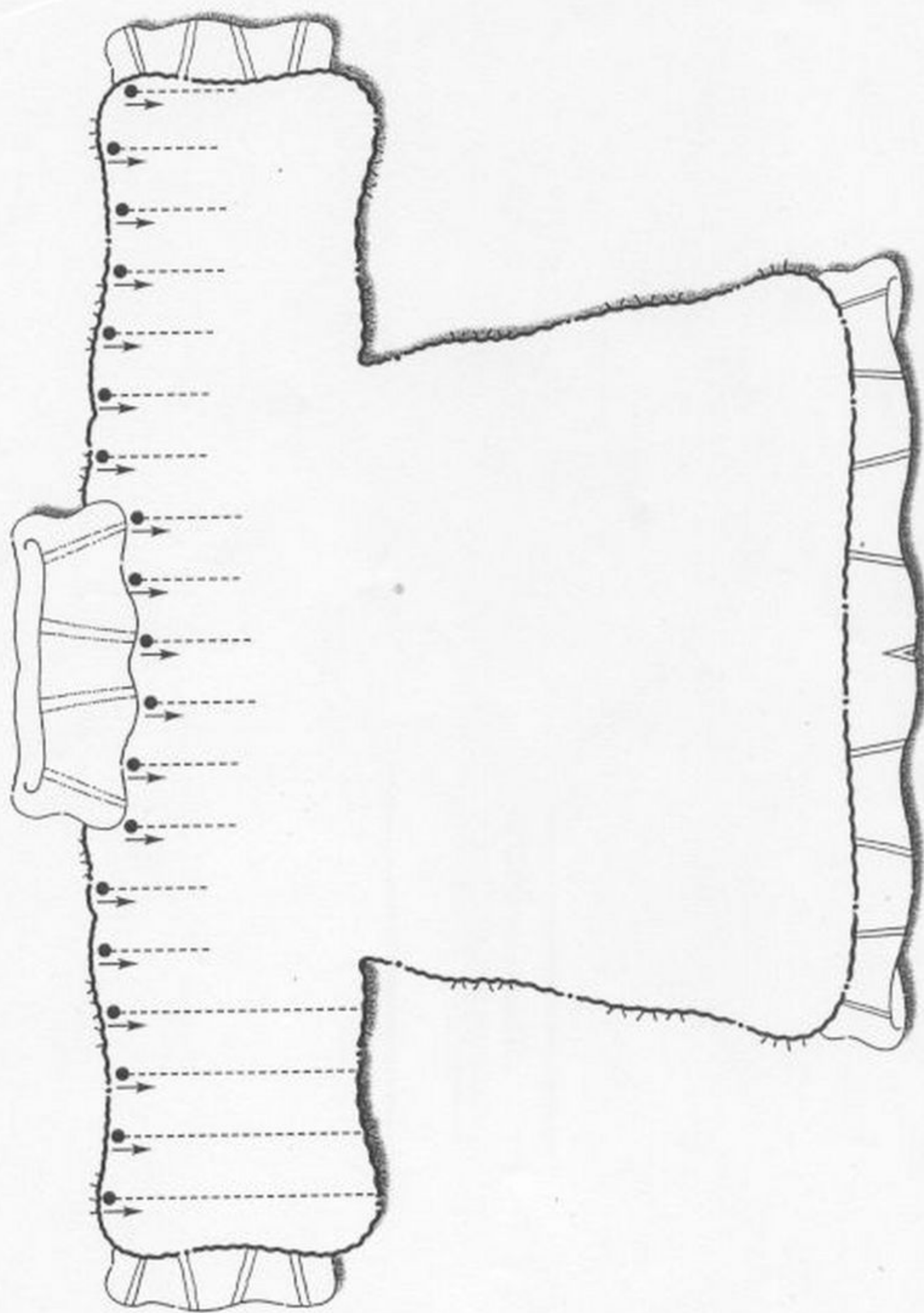

Un consejo: Después de trazar los caminitos, el niño o la niña puede colorear el fondo del jersey. Así trabajaremos la percepción "trazo sobre fondo".

E.E.I. MAR DE ALBORÁN





E.E.I. MAR DE ALBORÁN

<p>.....</p> <p>.....</p> <p>.....</p> <p>.....</p> <p>.....</p> <p>→</p>	<p>.....</p> <p>.....</p> <p>.....</p> <p>.....</p> <p>.....</p> <p>←</p>
---	---

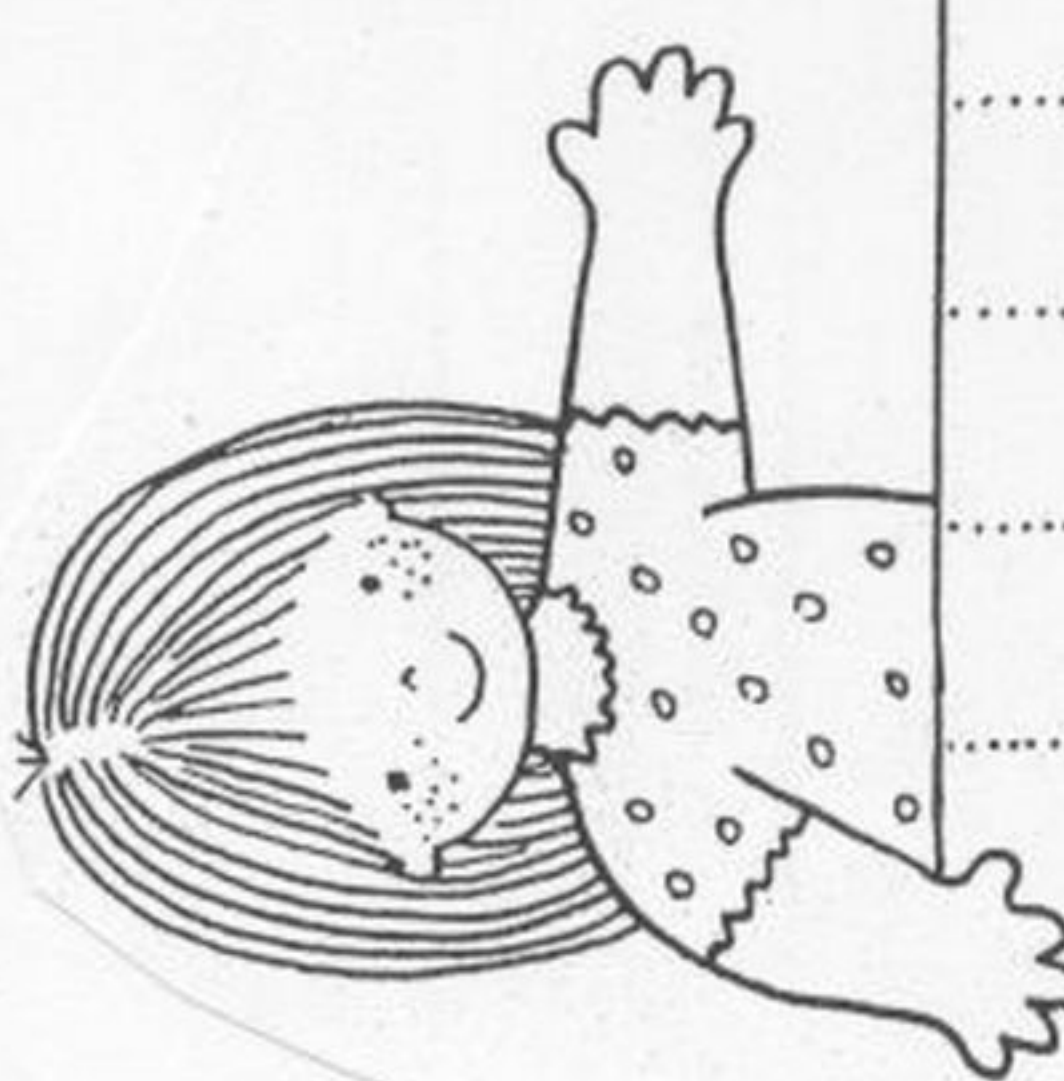
	<p>.....</p> <p>.....</p> <p>.....</p> <p>.....</p> <p>.....</p> <p>.....</p> <p>.....</p> <p>.....</p> <p>.....</p> <p>.....</p> <p>.....</p>
	<p>.....</p> <p>.....</p>



E.E.I. MAR DE ALBORÁN

A vertical grid of 20 squares with a dashed line down the center, used for handwriting practice.



A horizontal grid of 20 squares with a dashed line down the center, used for handwriting practice.



E.E.I. MAR DE ALBORÁN

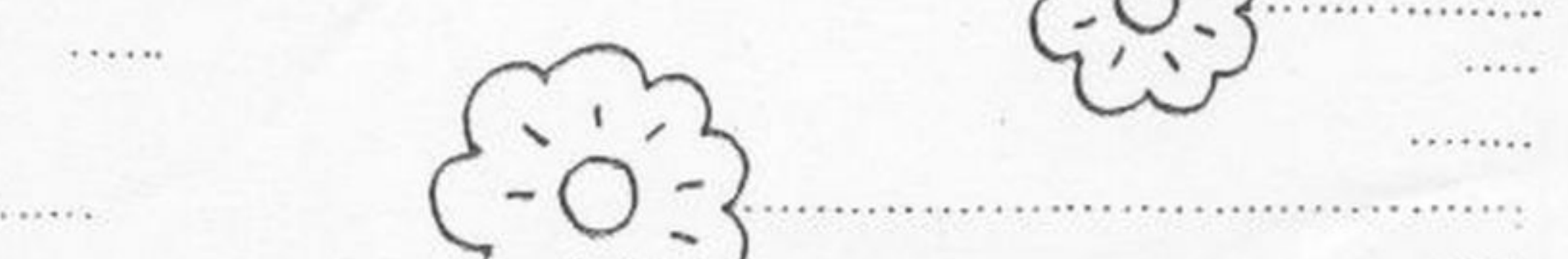
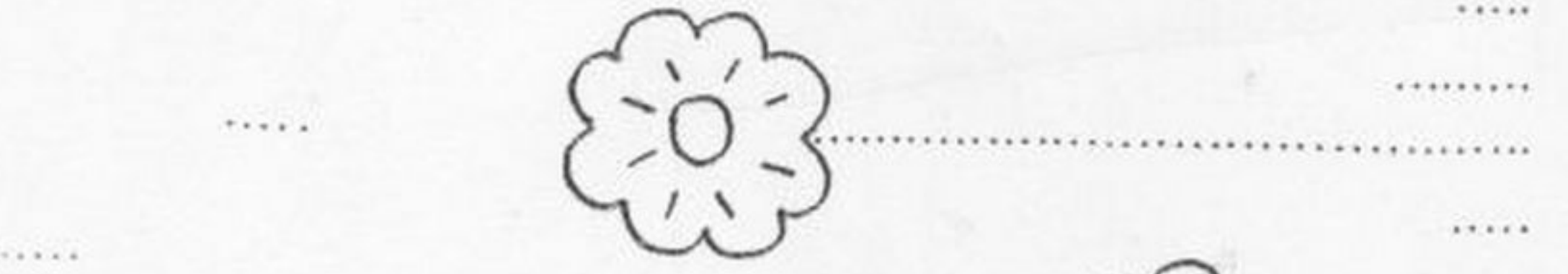
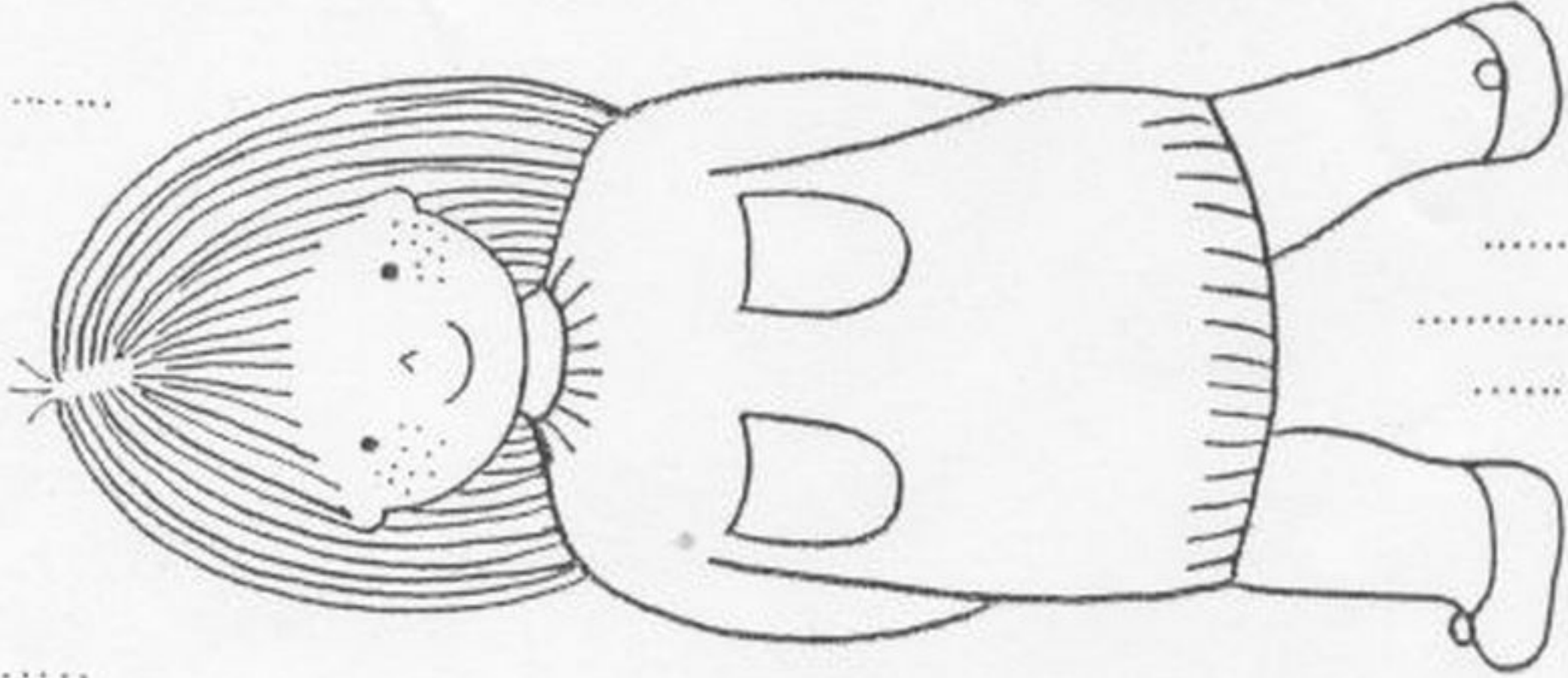
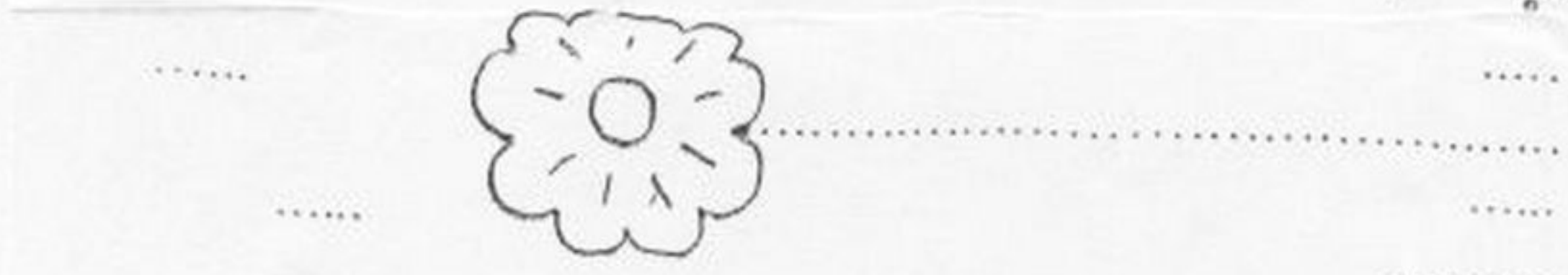

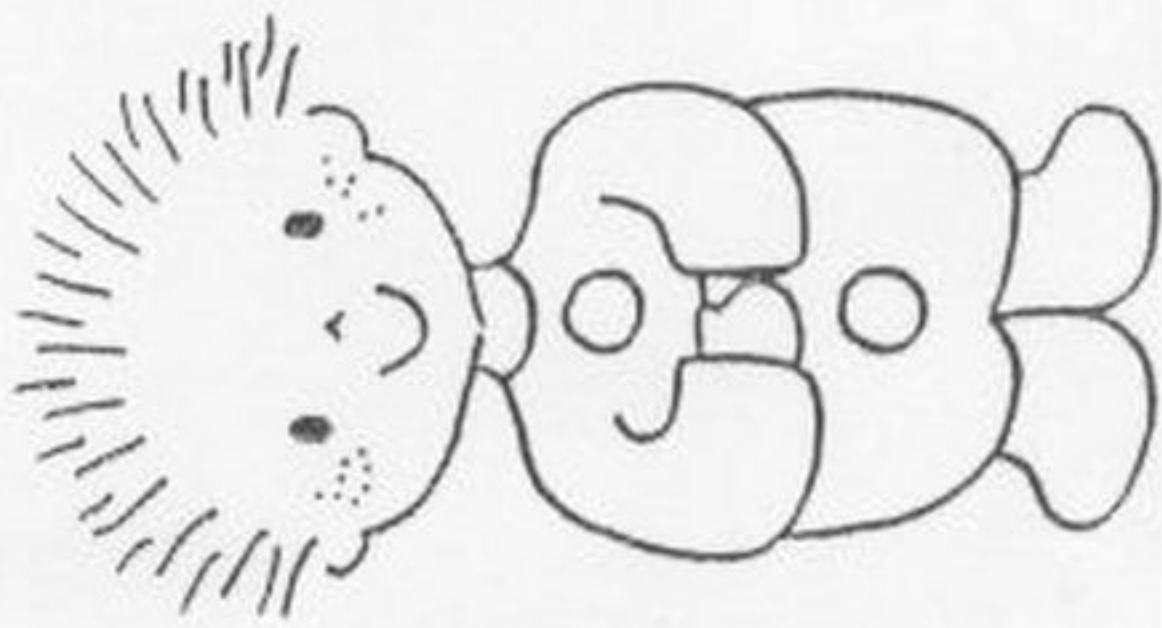
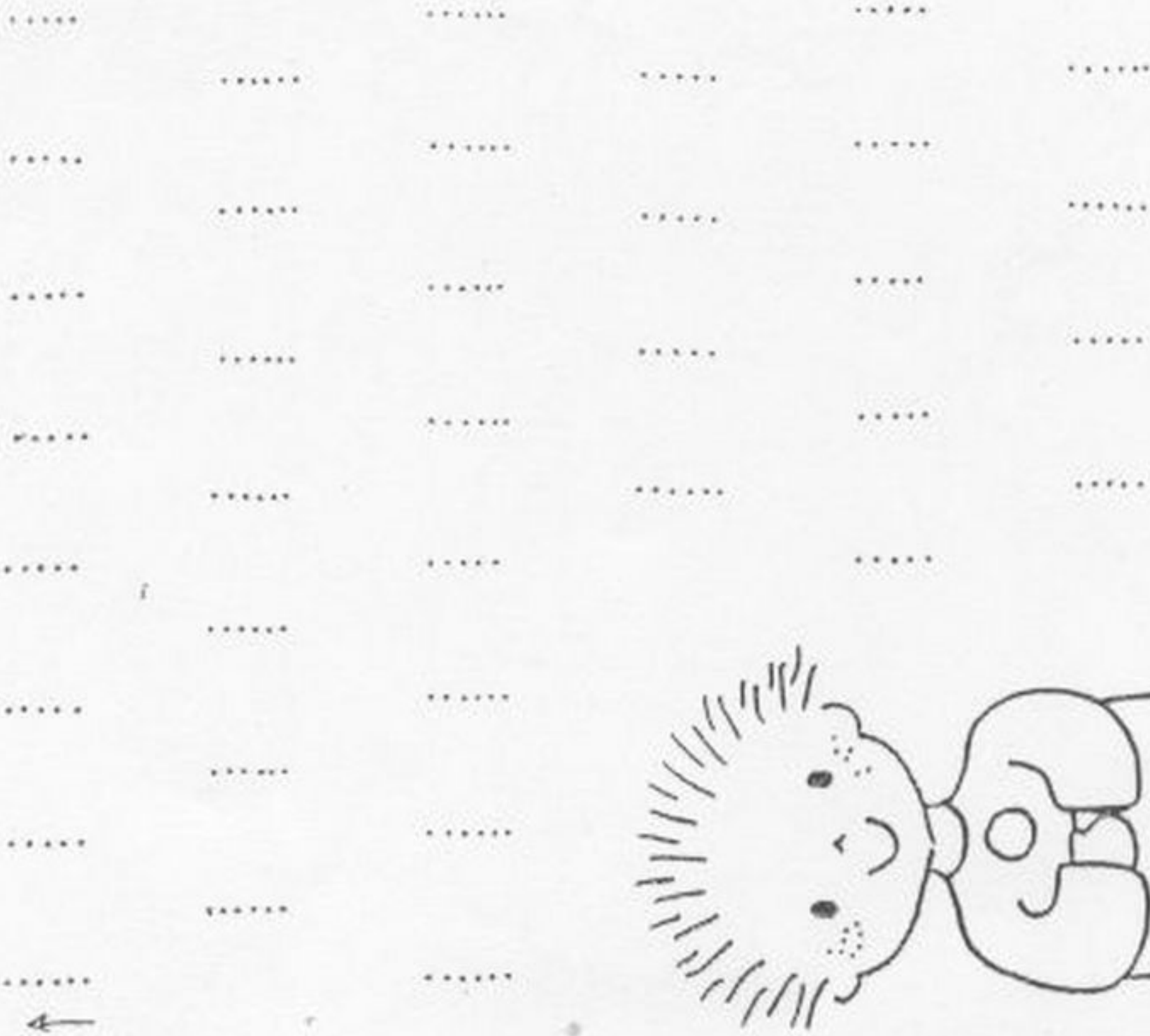

E.E.I. MAR DE ALBORÁN

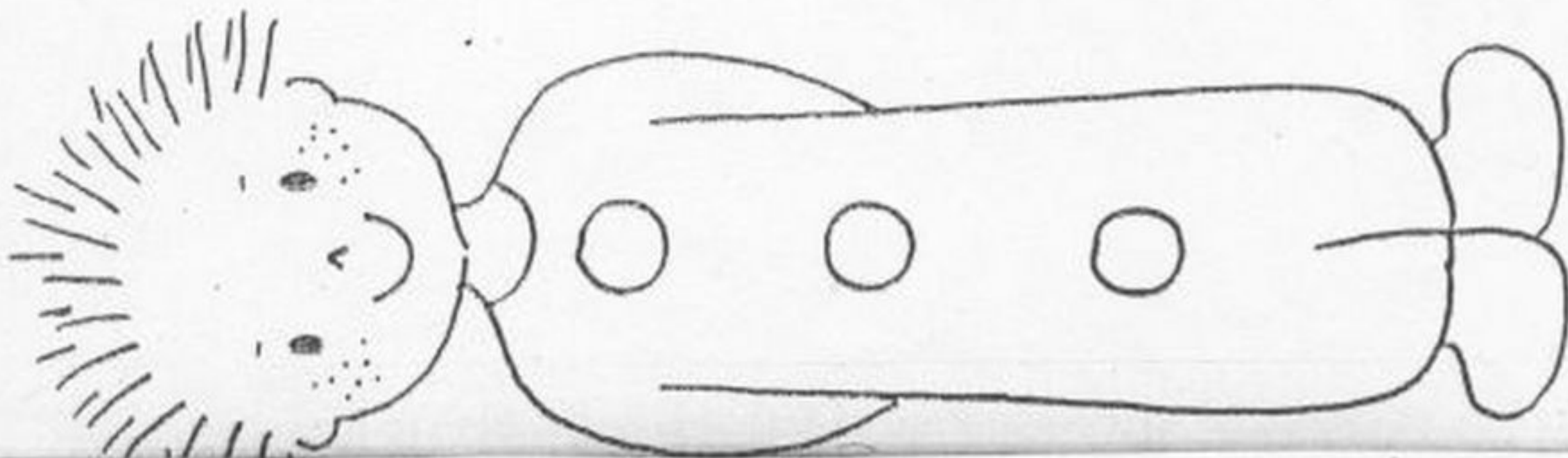
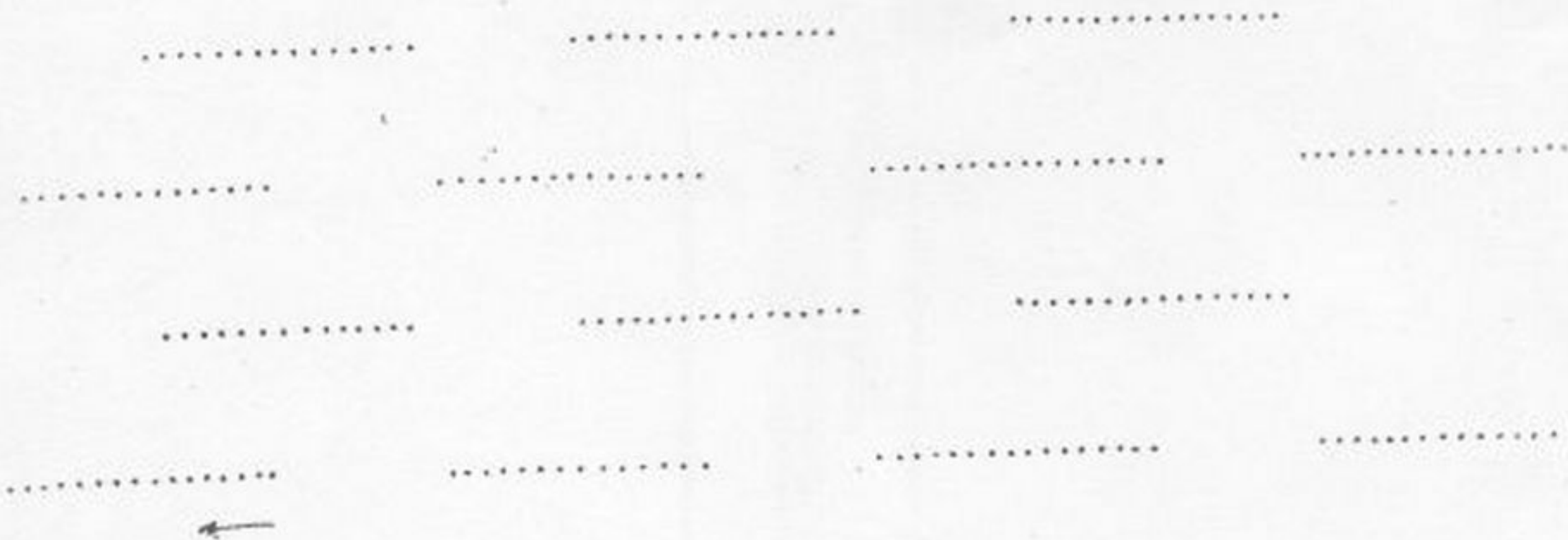

- Siguiendo la dirección que indican las flechas, repasar con ceras blandas.
- Realizar las grafías.

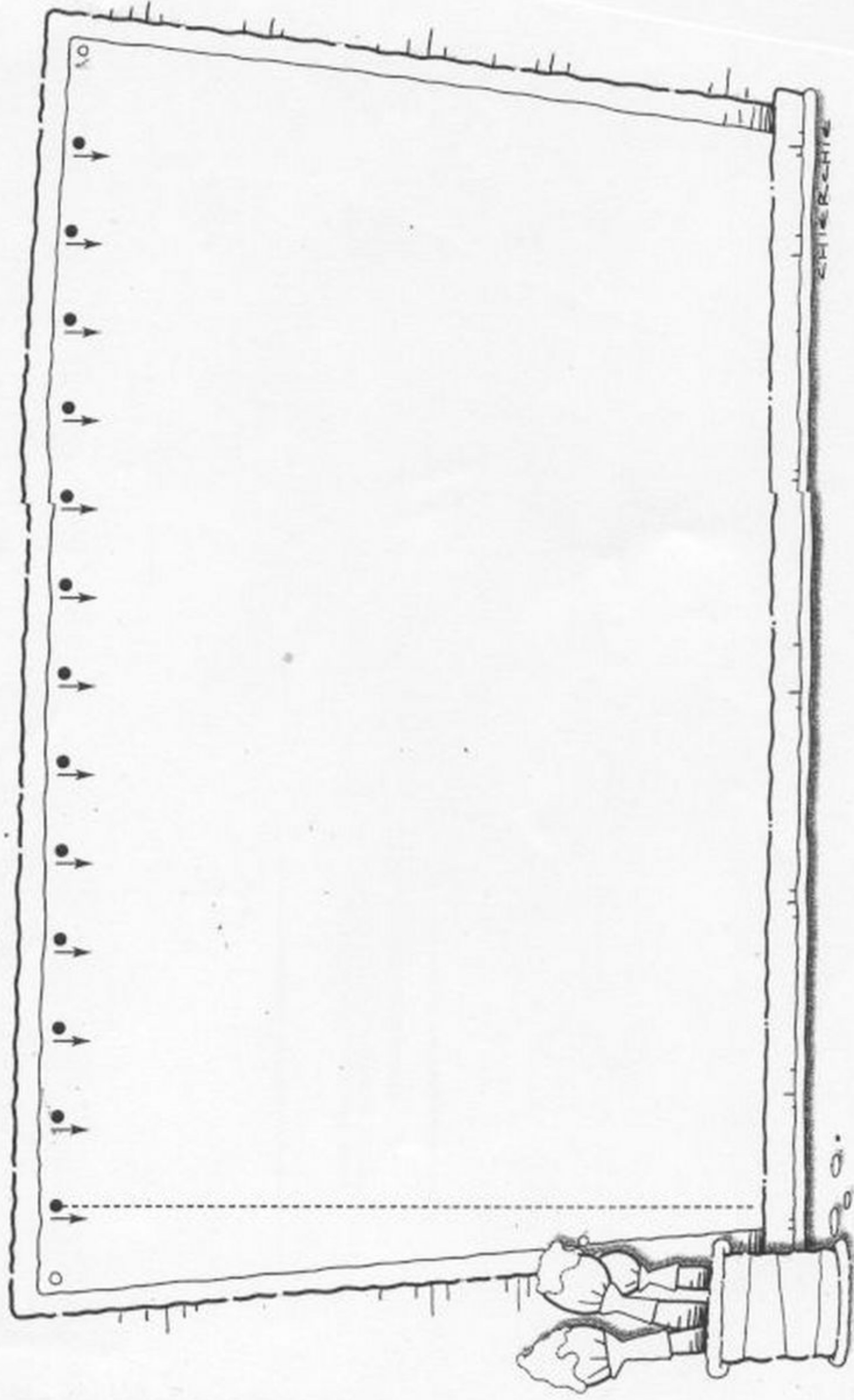

- *Reseguir* los trazos con rotulador fino.
- Realizar las grafías siguiendo la dirección de las flechas.

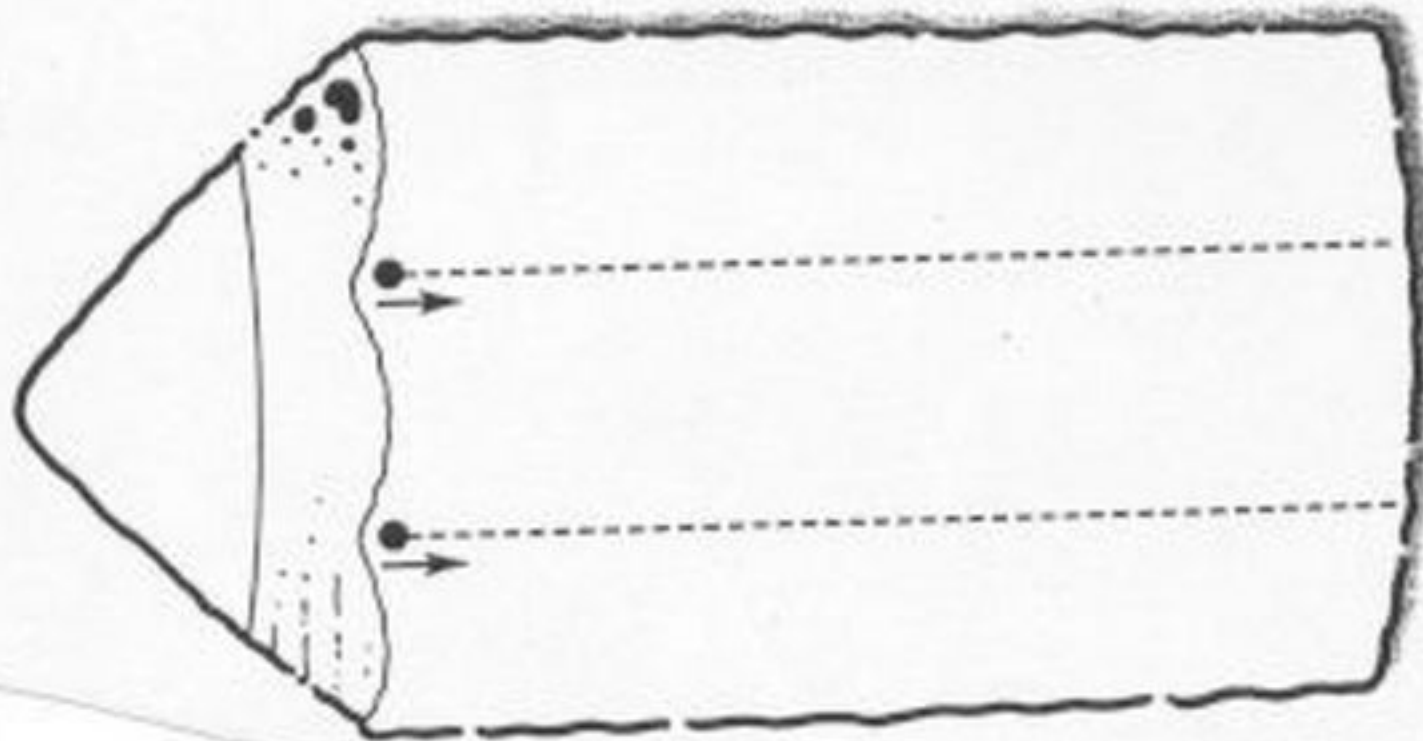
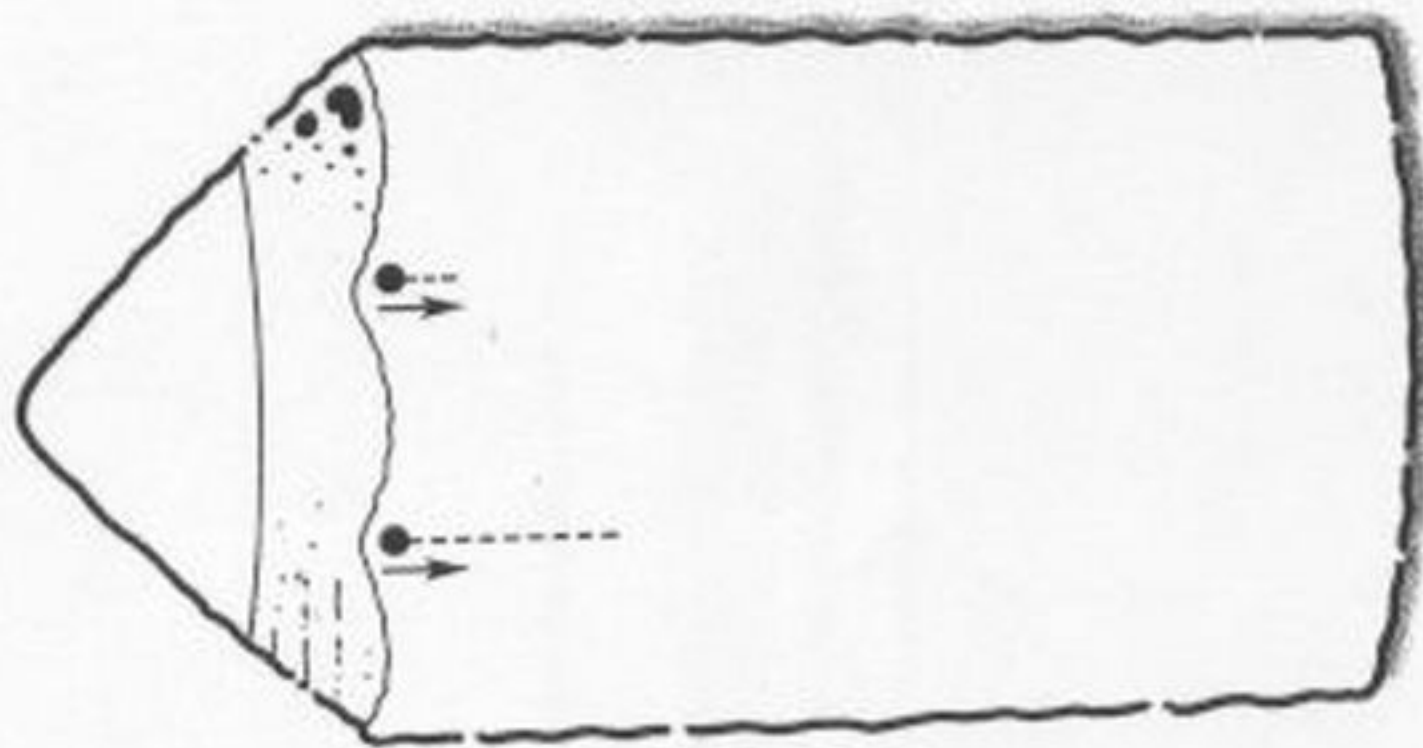
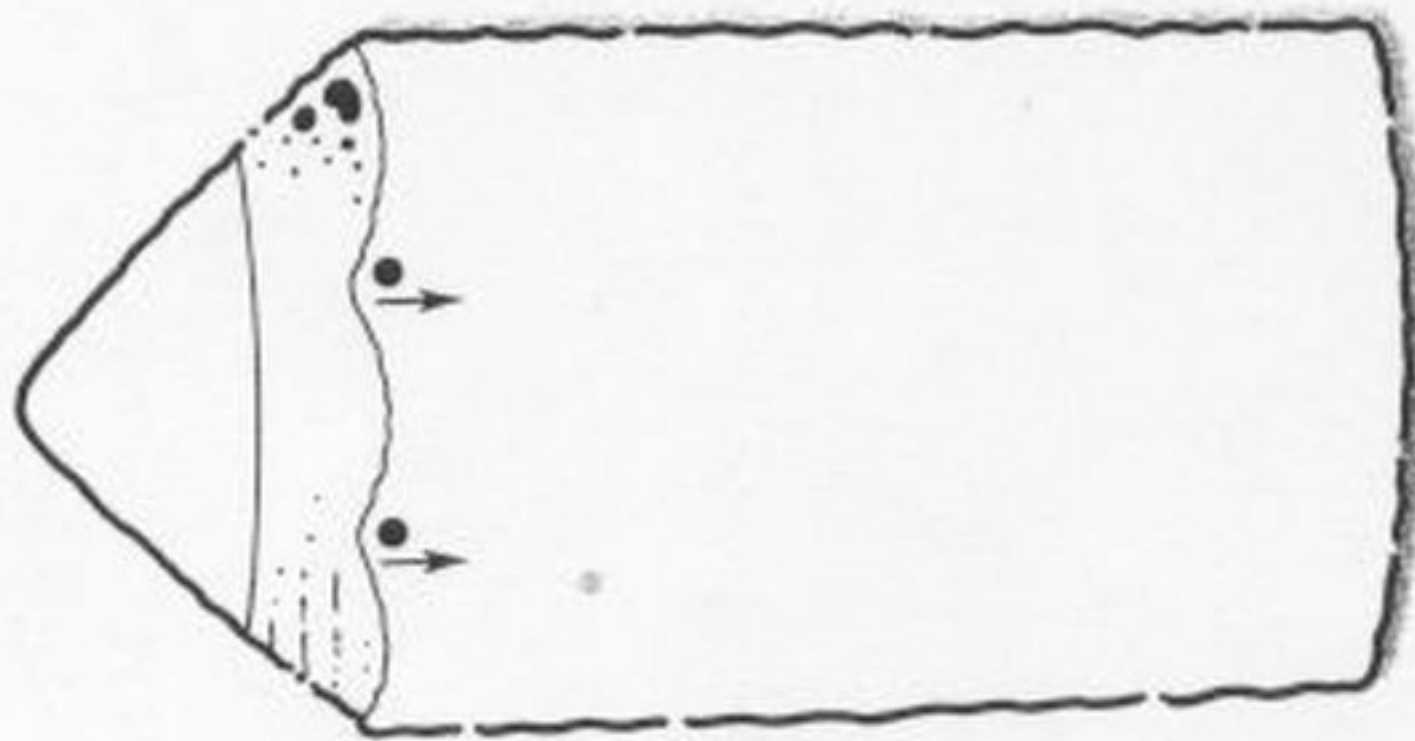
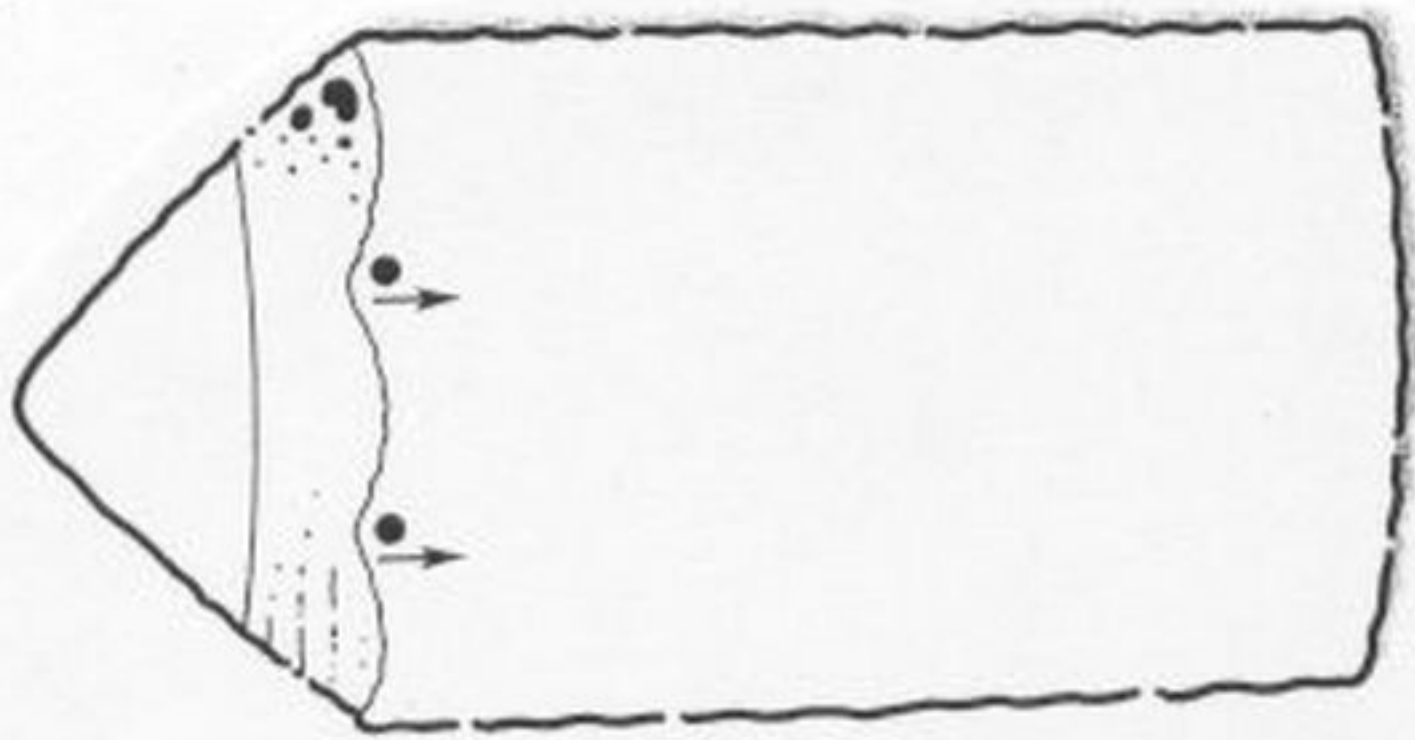

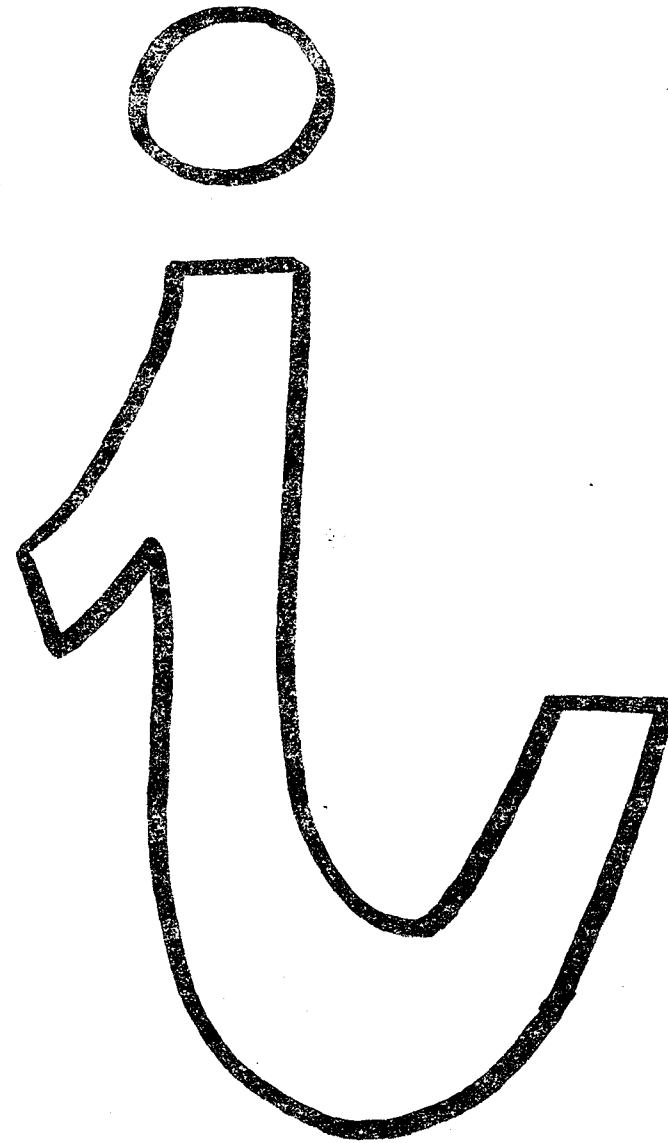
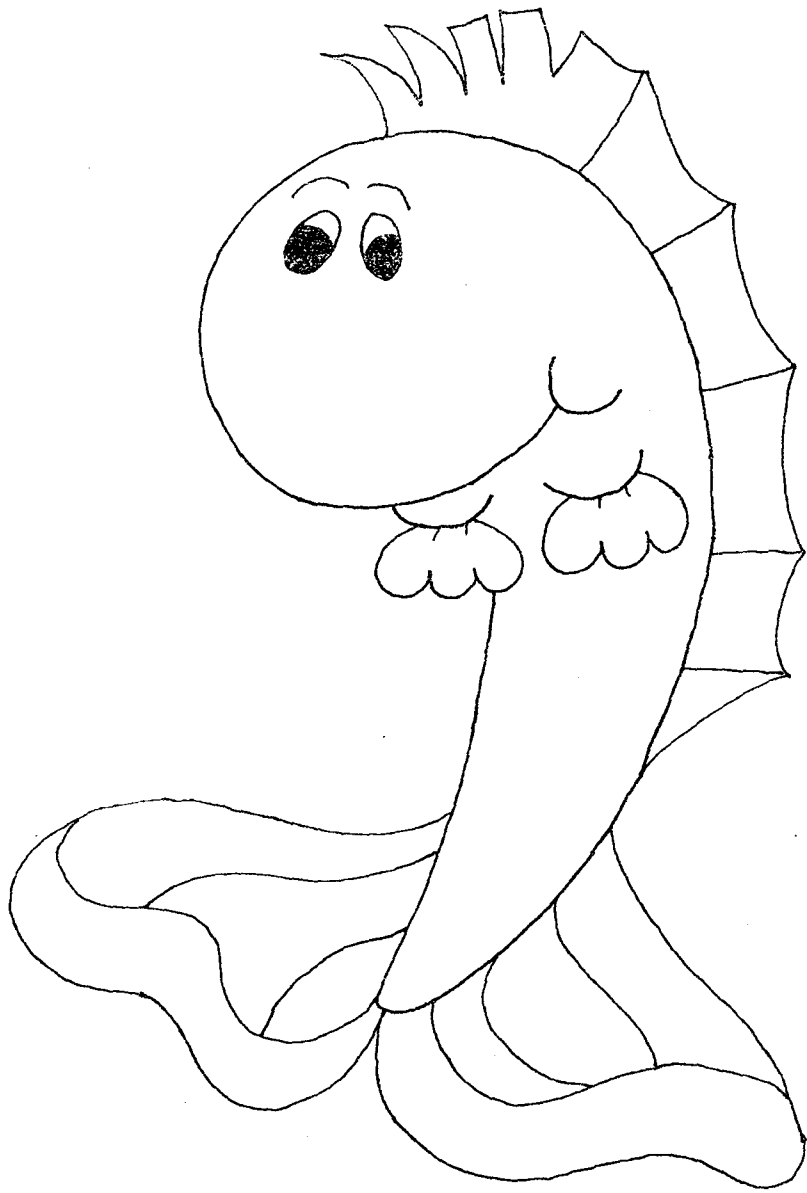

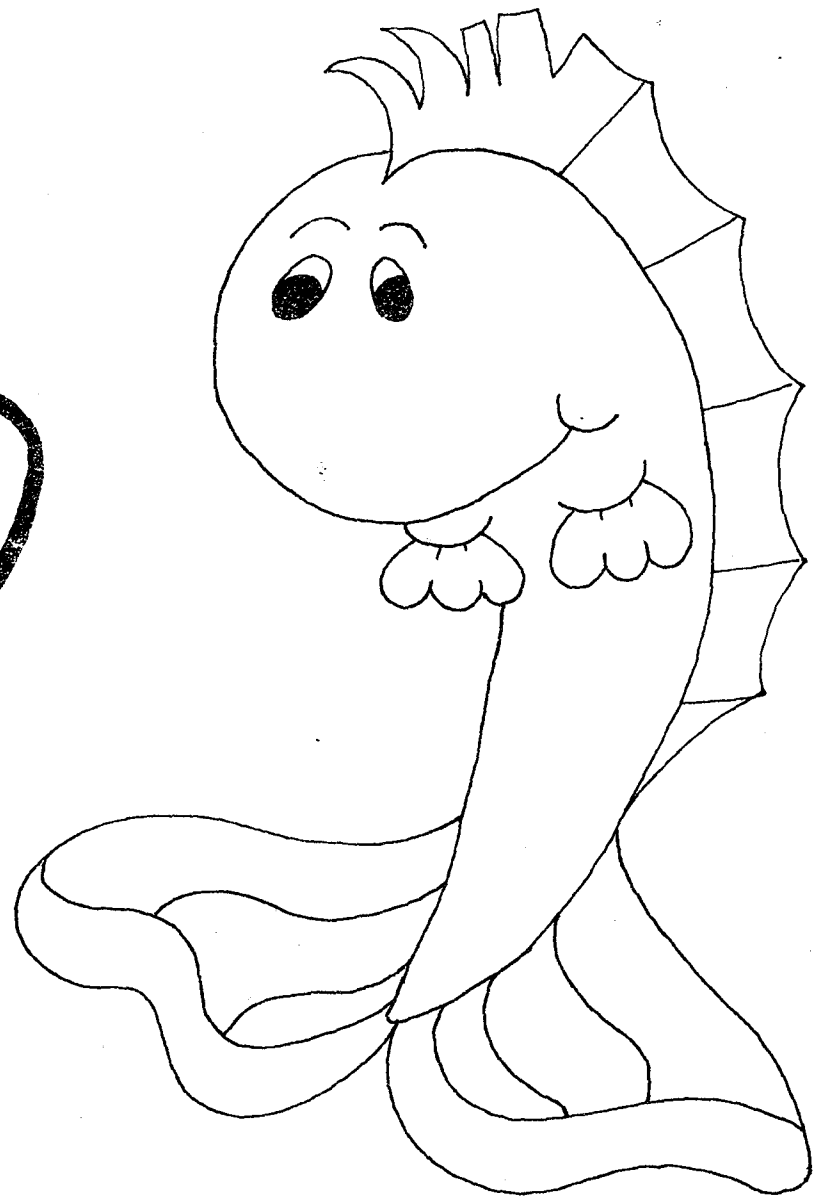
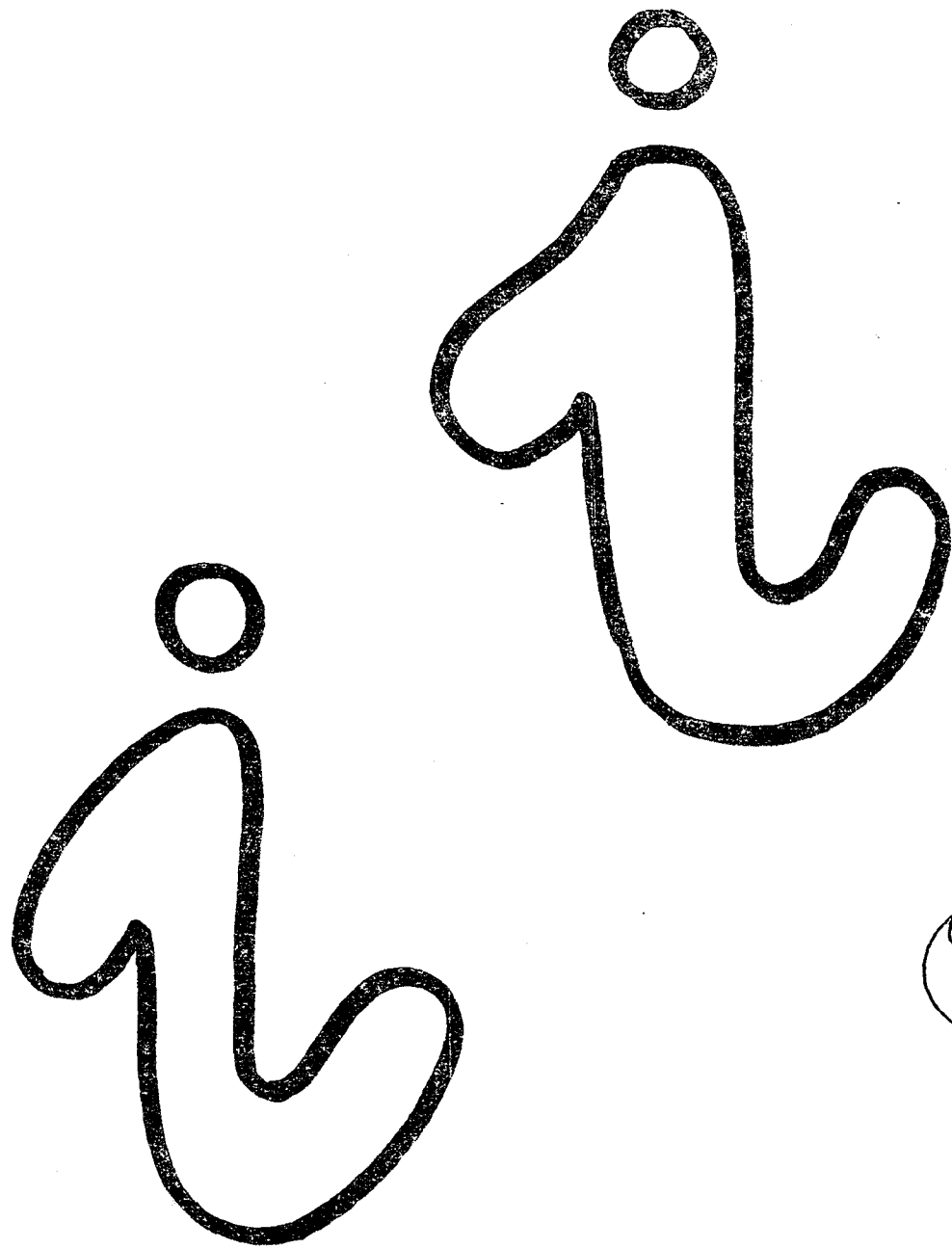

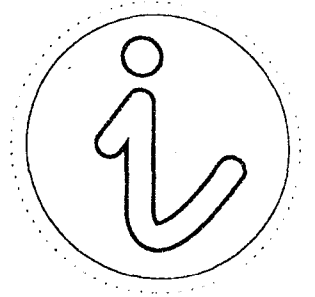
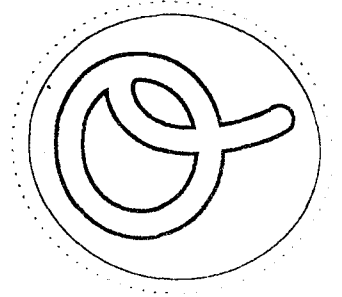
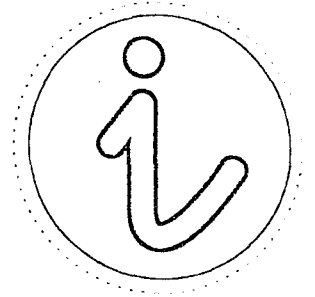
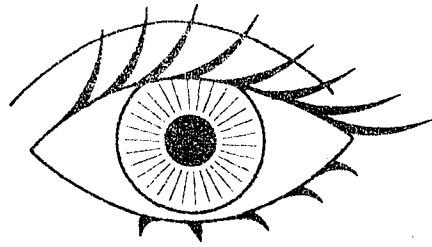
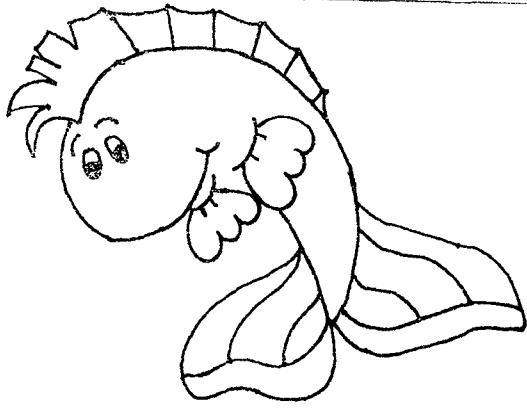

i	i	i	i	i	i	i	i	i
.
.
.
.



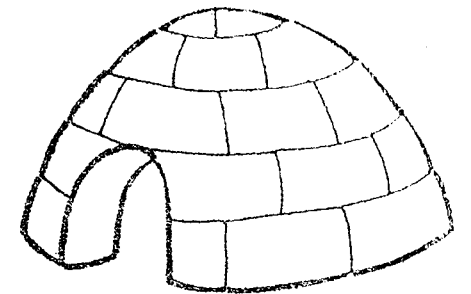
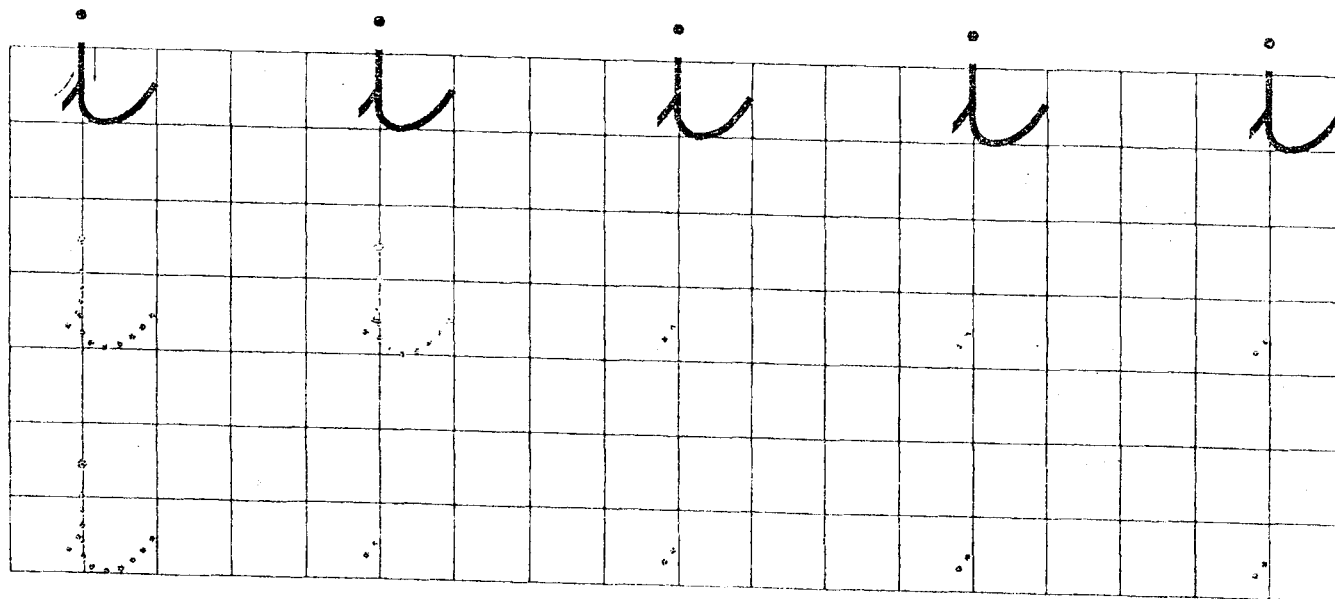
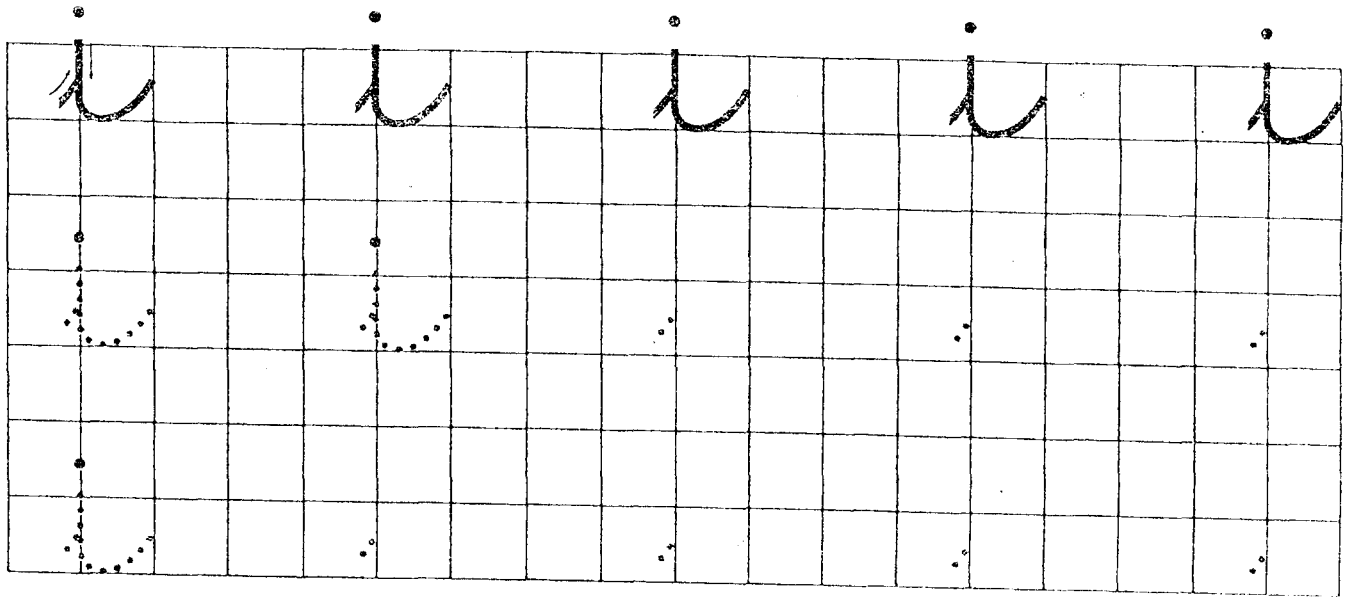
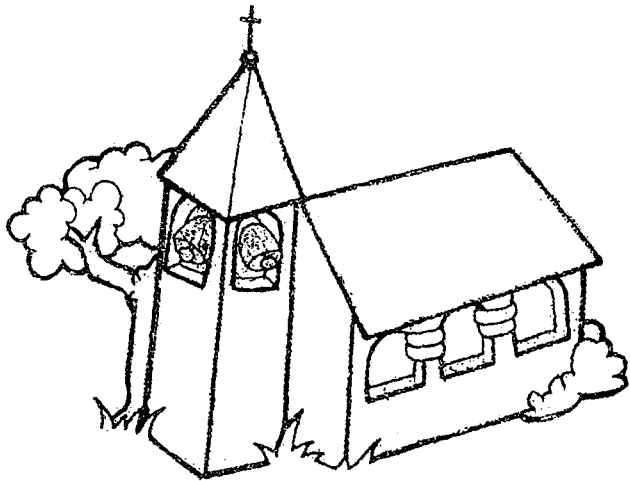

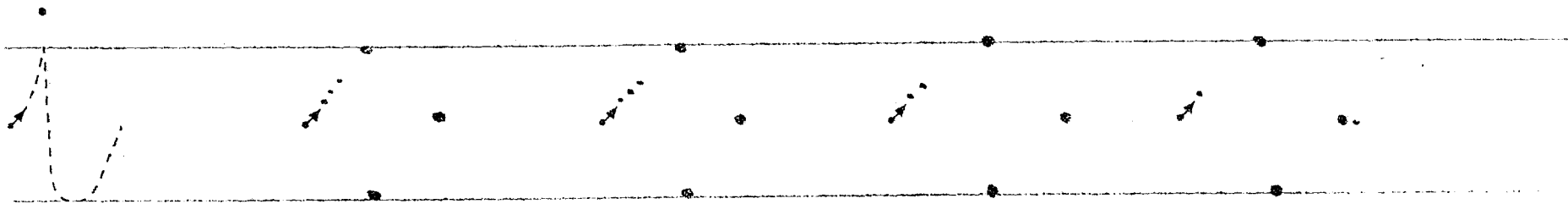
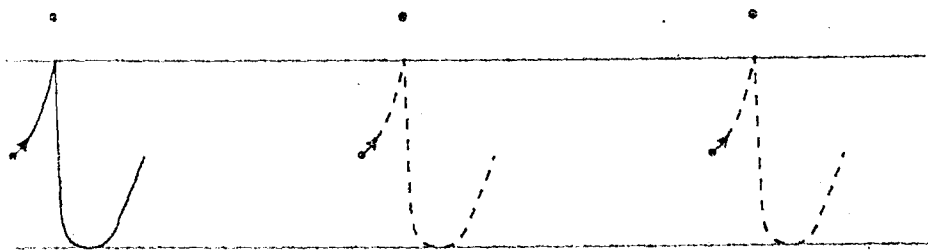
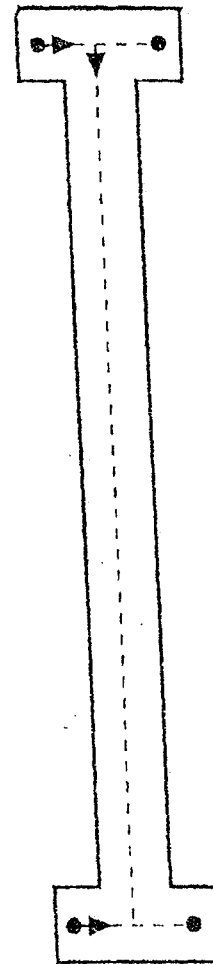
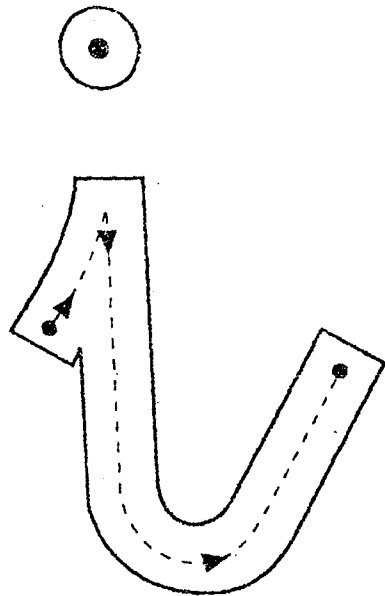

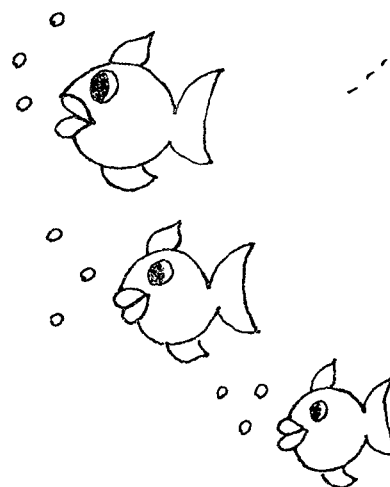
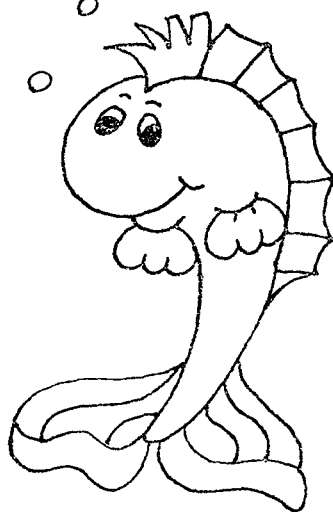
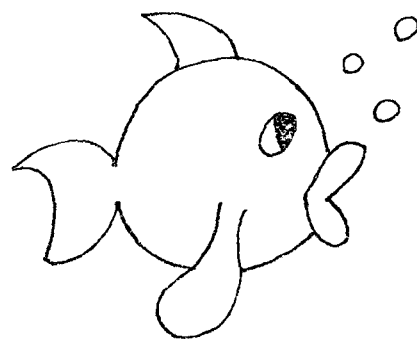
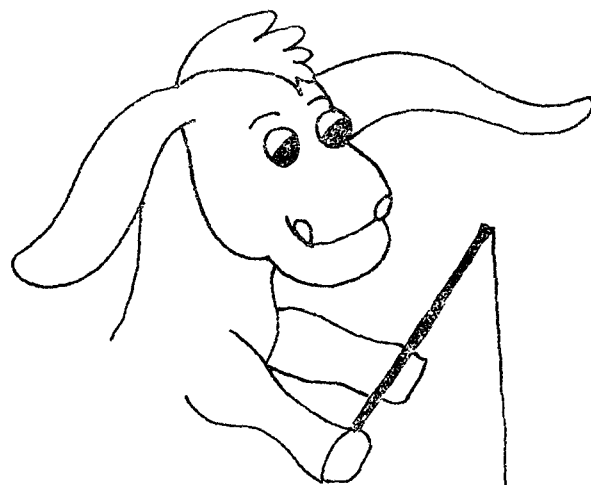
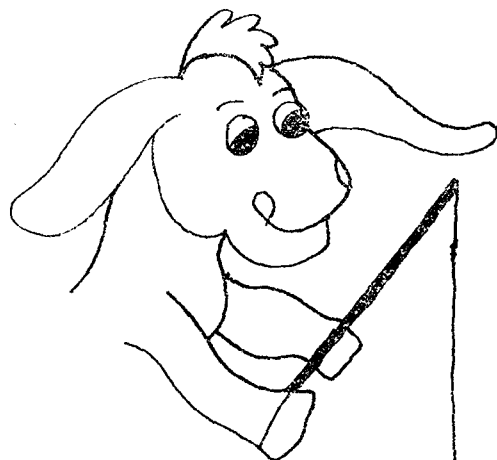
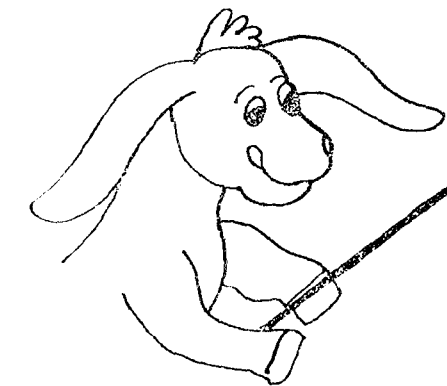

E.E.I. MAR DE ALBORÁN

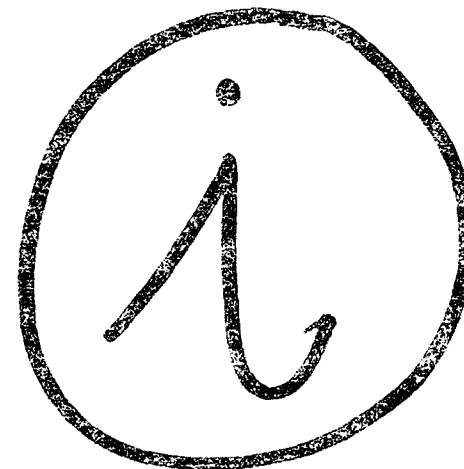
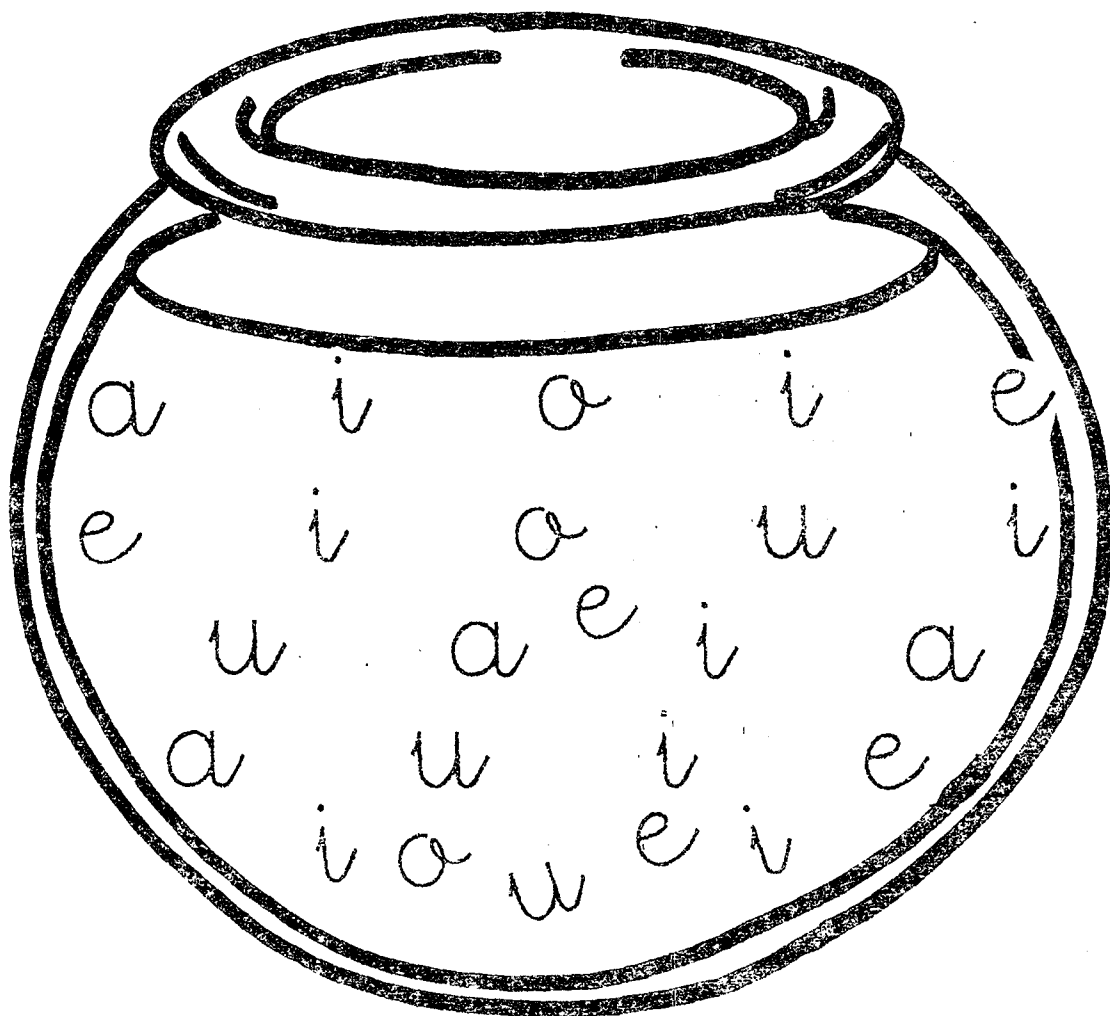

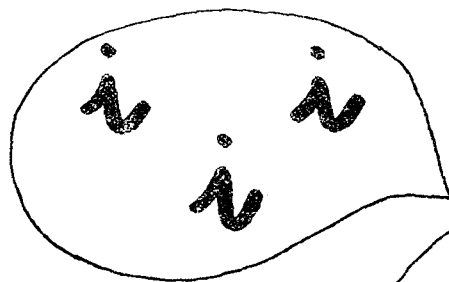
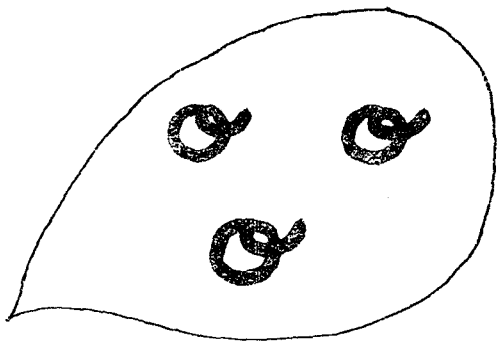
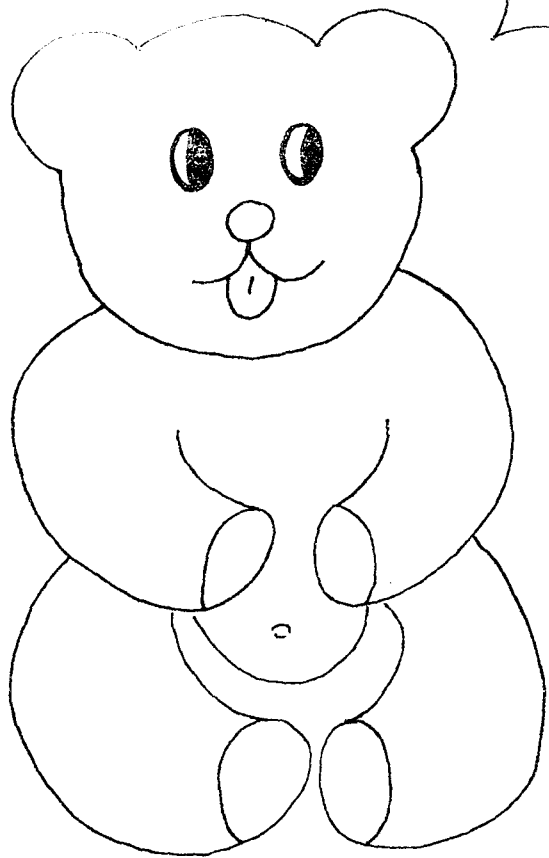

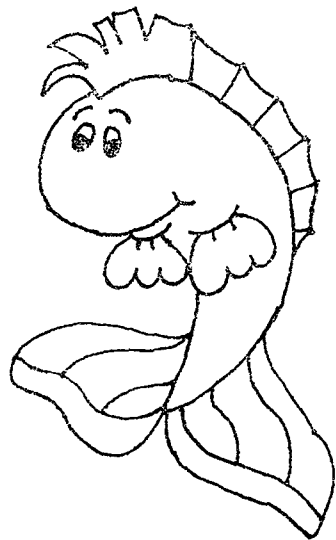

Tris

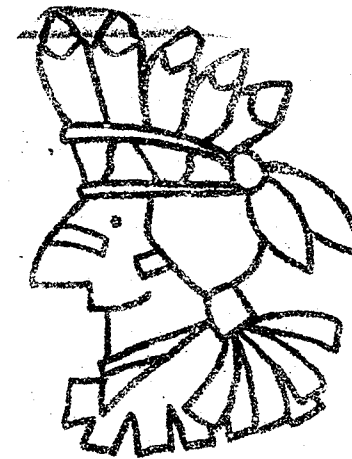
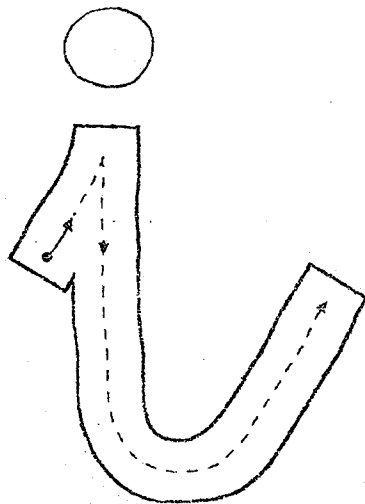

indio

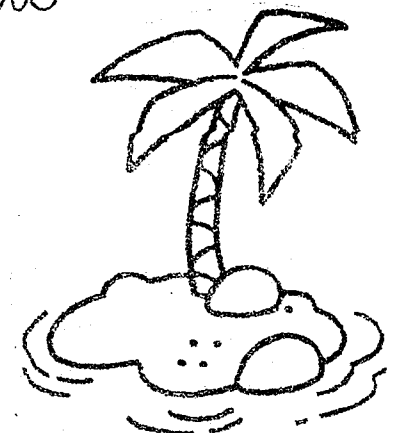
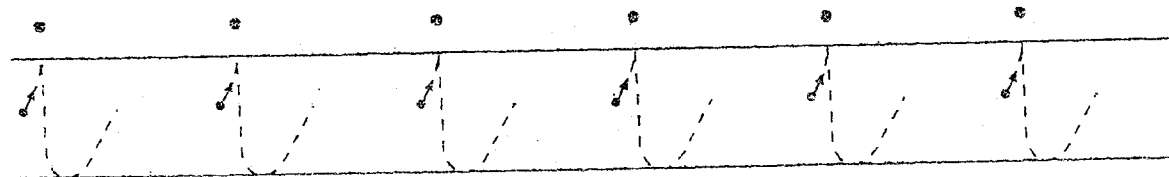
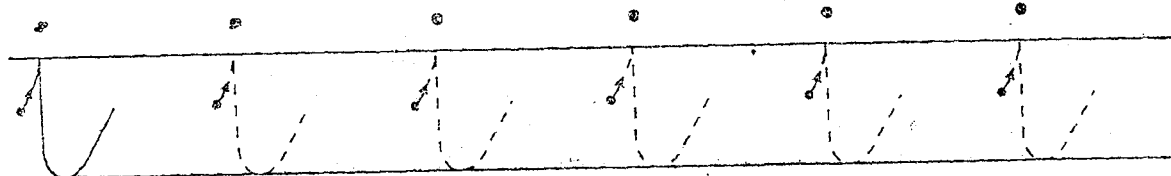

isla



i i i
i i i

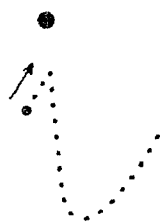
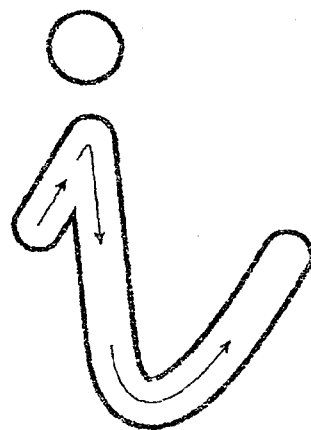
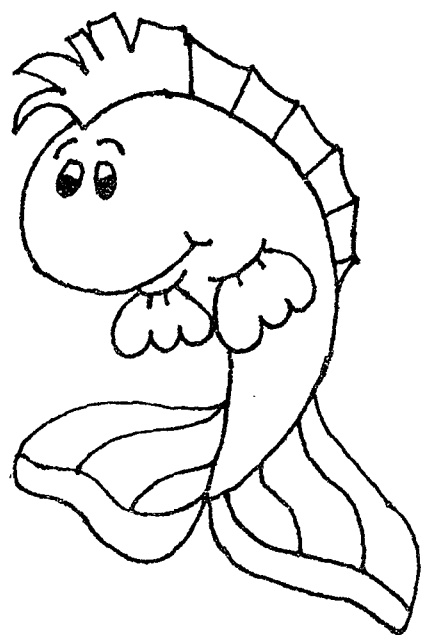

E.E.I. MAR DE ALBORÁN

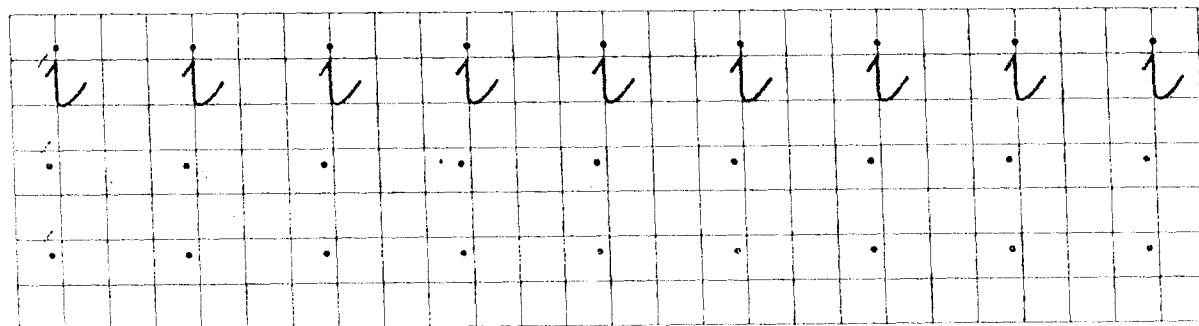
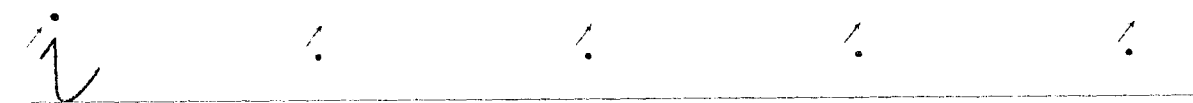
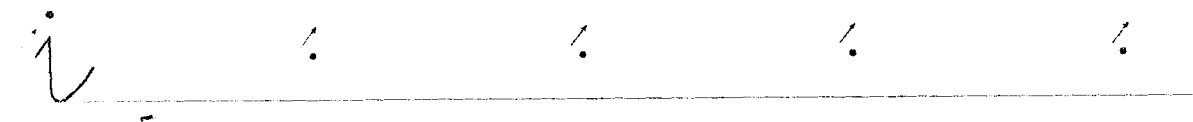
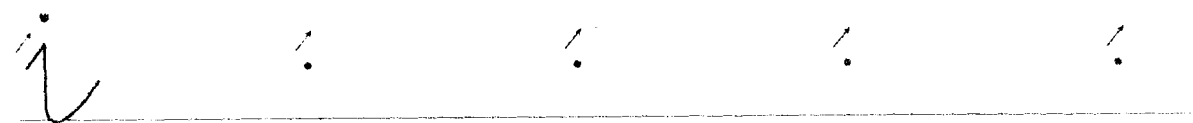
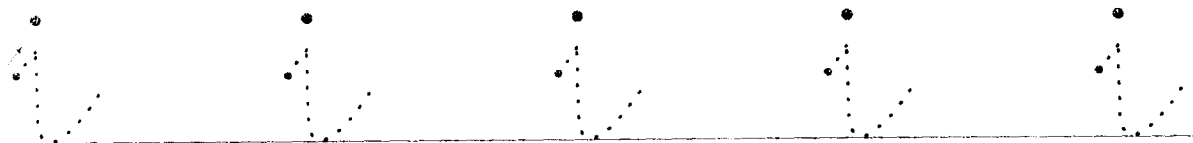
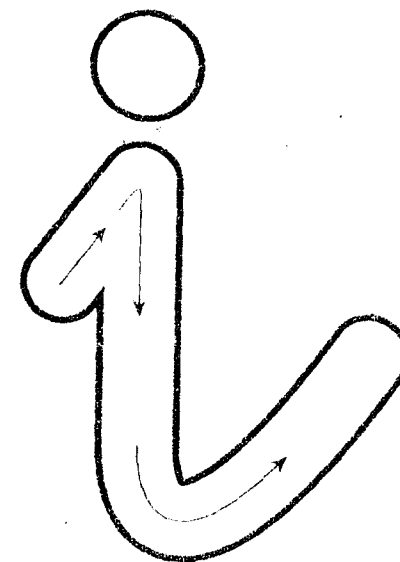

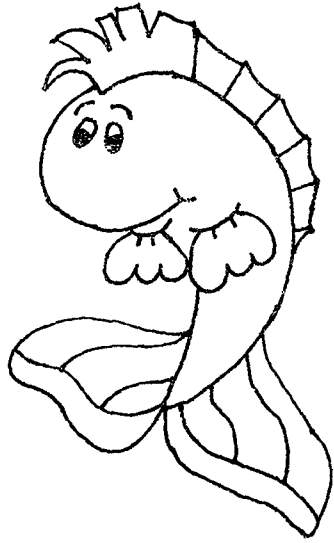

Tris

iglesia

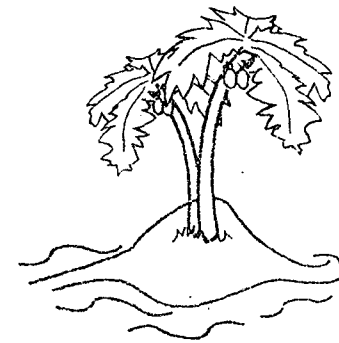
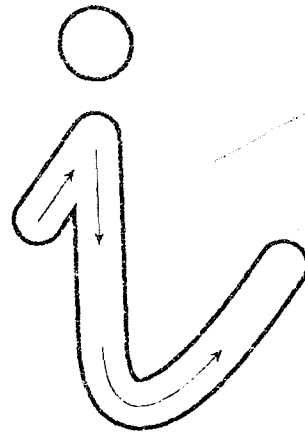
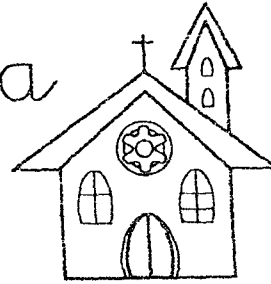

isla

hueso

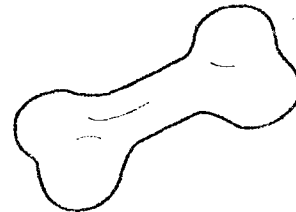

i	i	i	i	i	i	i	i	i	i
.
.



Rodear la grafía de la i en las palabras
y colorear los dibujos que la tienen en su nombre.

i

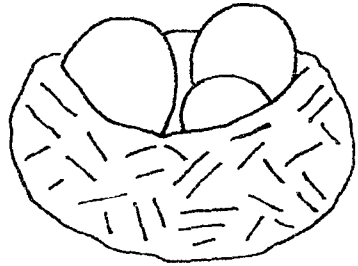

nido

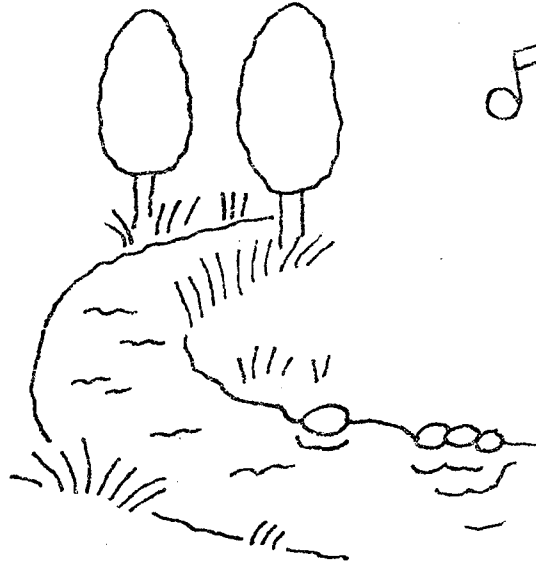

río

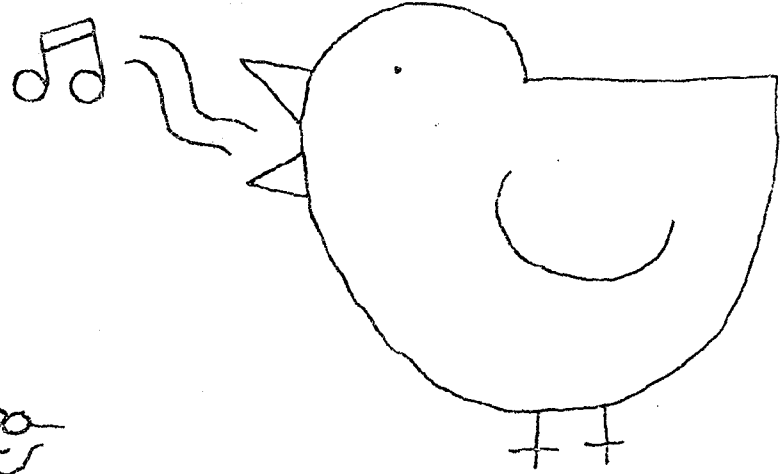

pío-pío

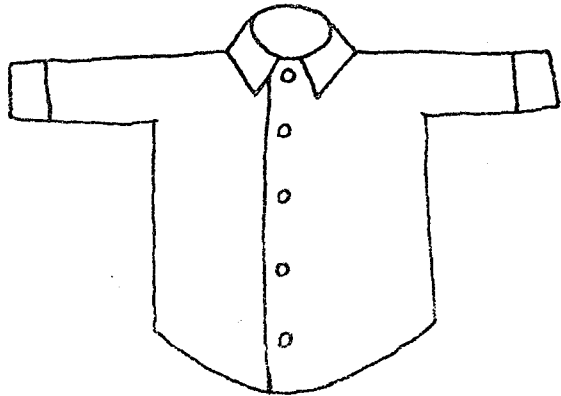

camisa

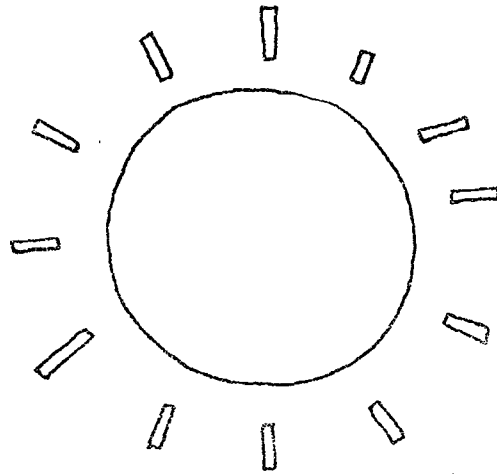

sol

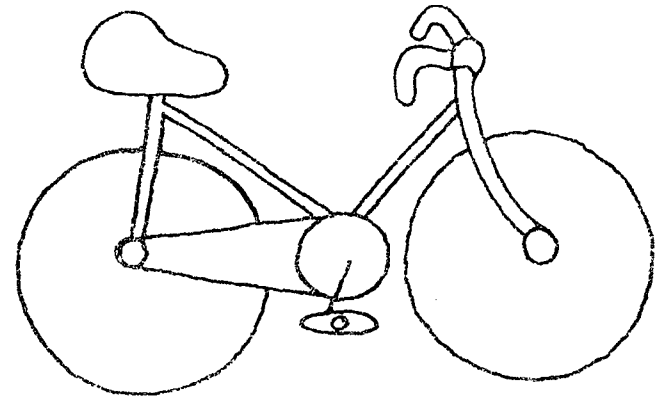

bicicleta

E.E.I. MAR DE ALBORÁN



• Rodear la letra *v* en las siguientes palabras.

neve

pato

iglu

niño

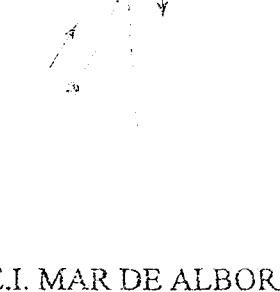
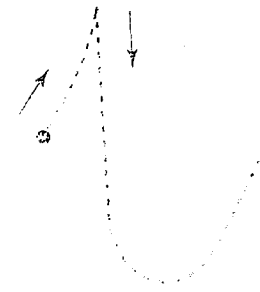
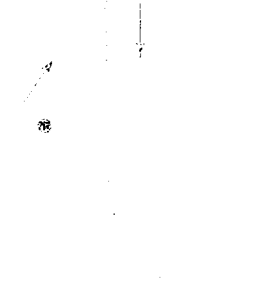
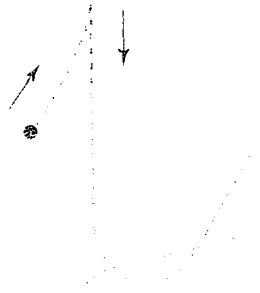
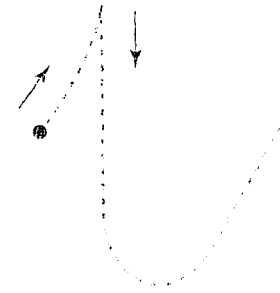
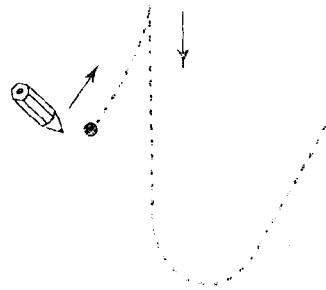

★ Colorear el dibujo cuyo nombre contenga el fonema *i*.

I

i

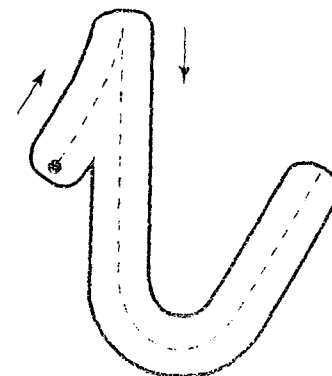
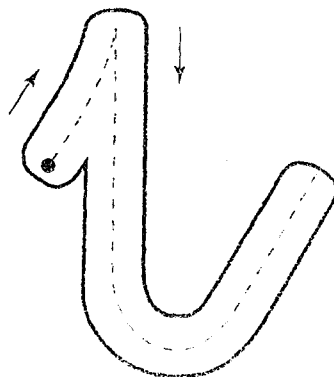
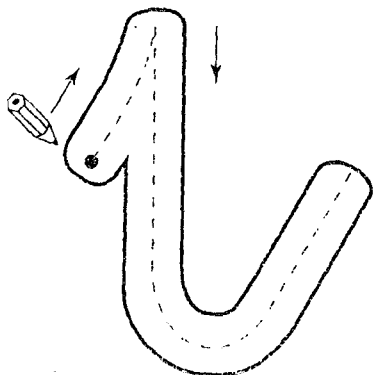
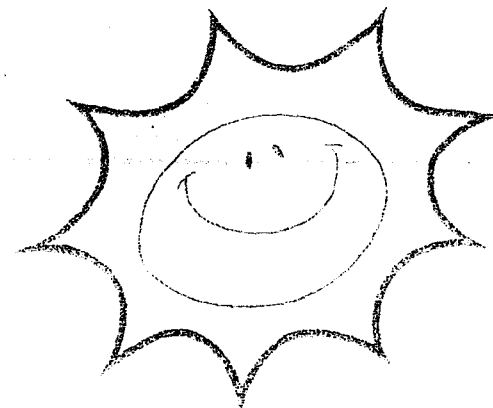
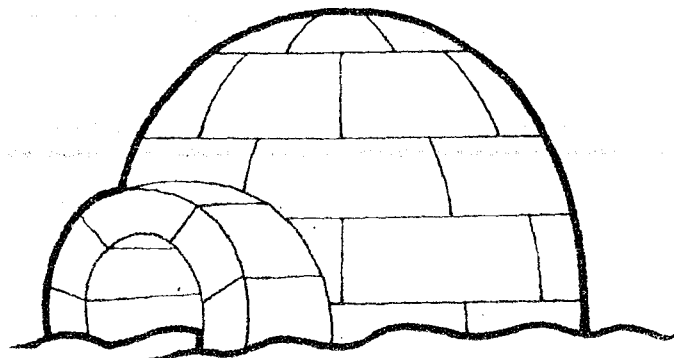

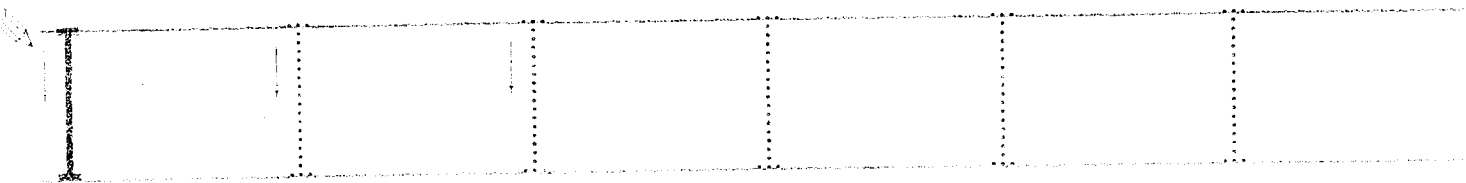
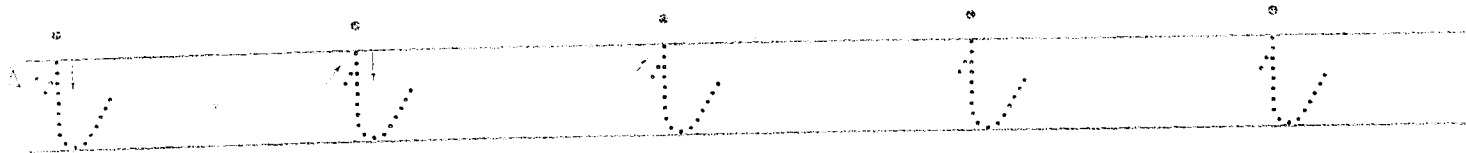
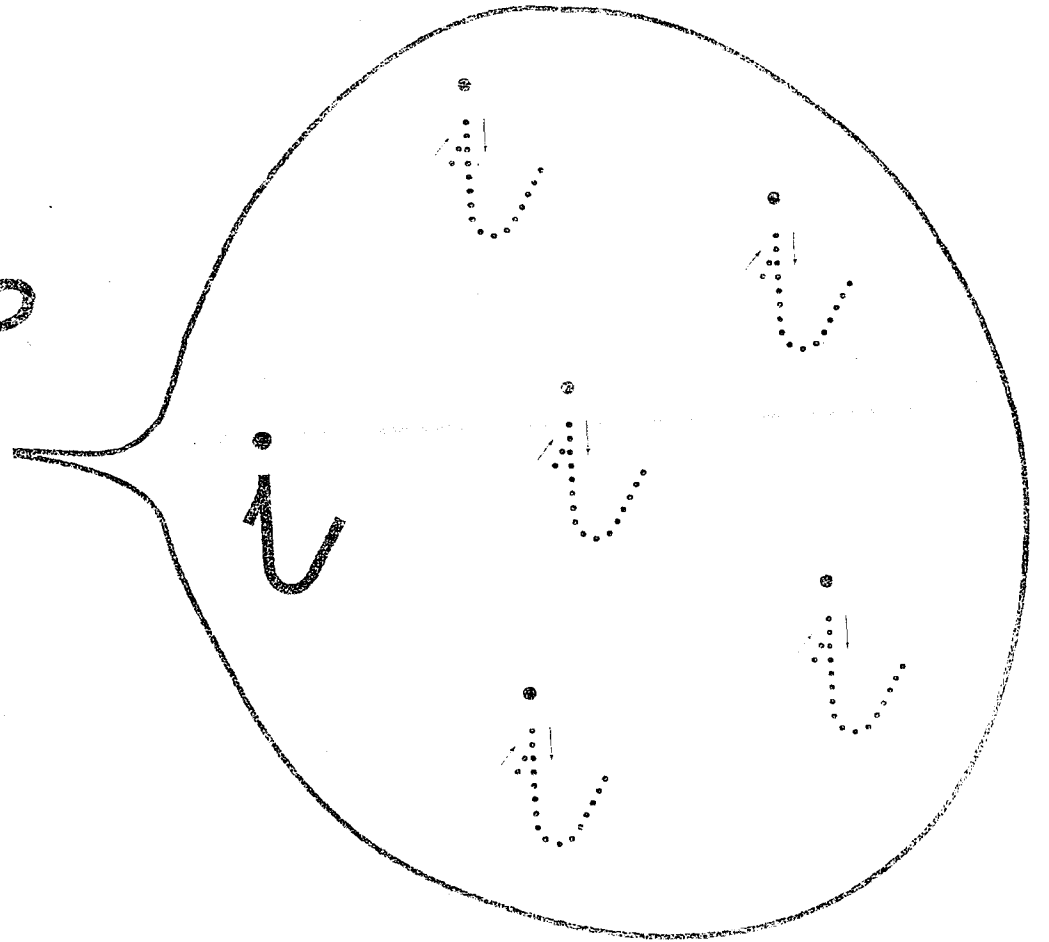
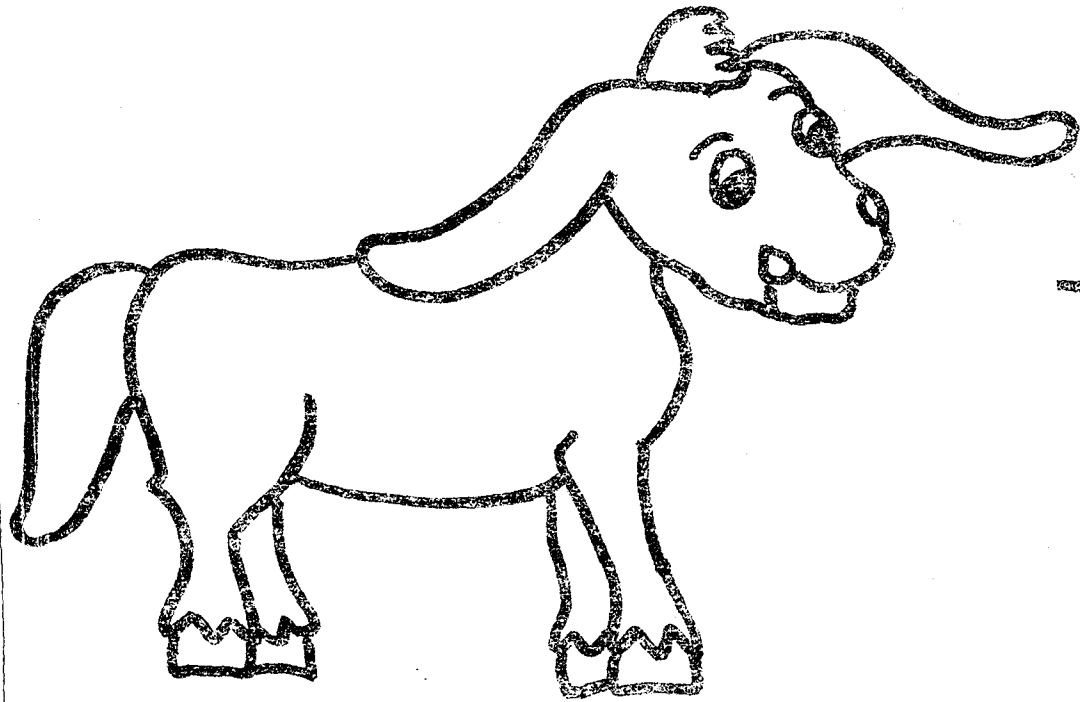

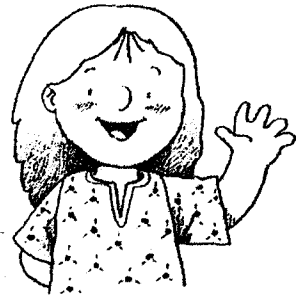
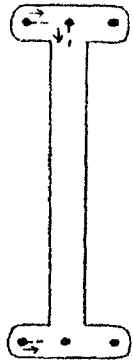

Inés

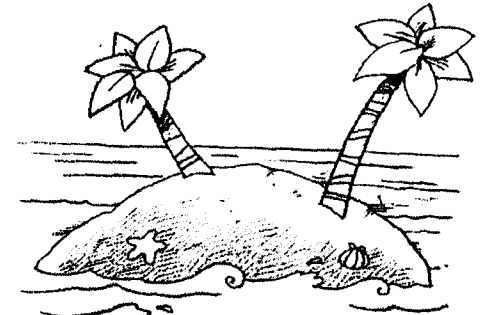
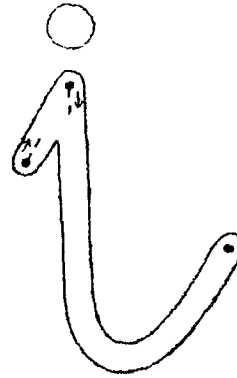

isla

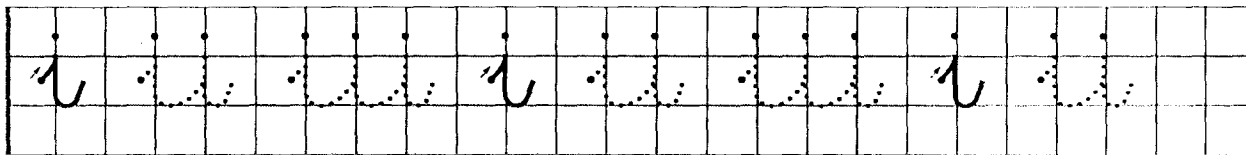
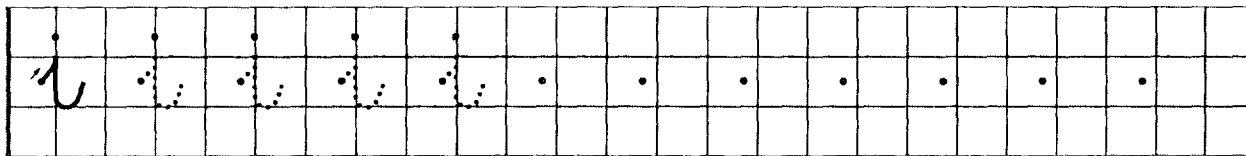
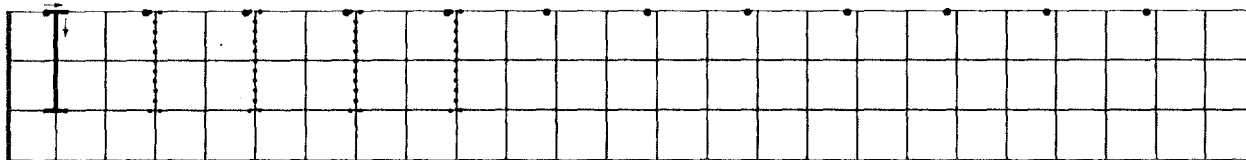
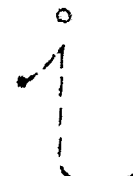
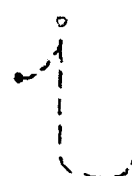
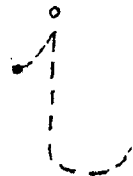
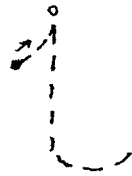

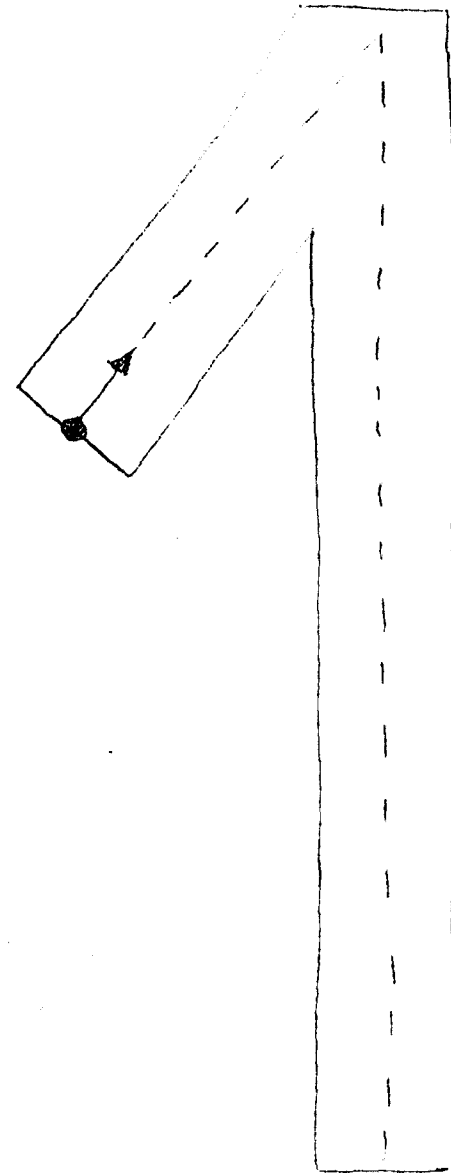

E.E.I. MAR DE ALBORÁN



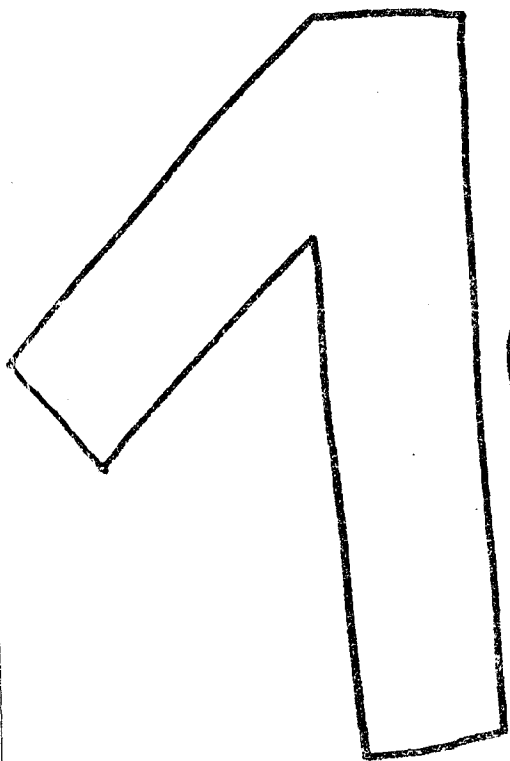

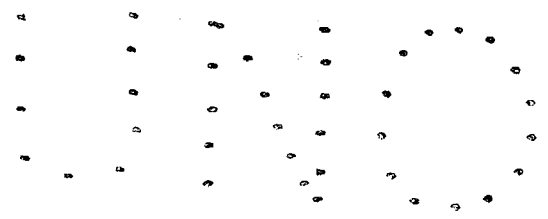
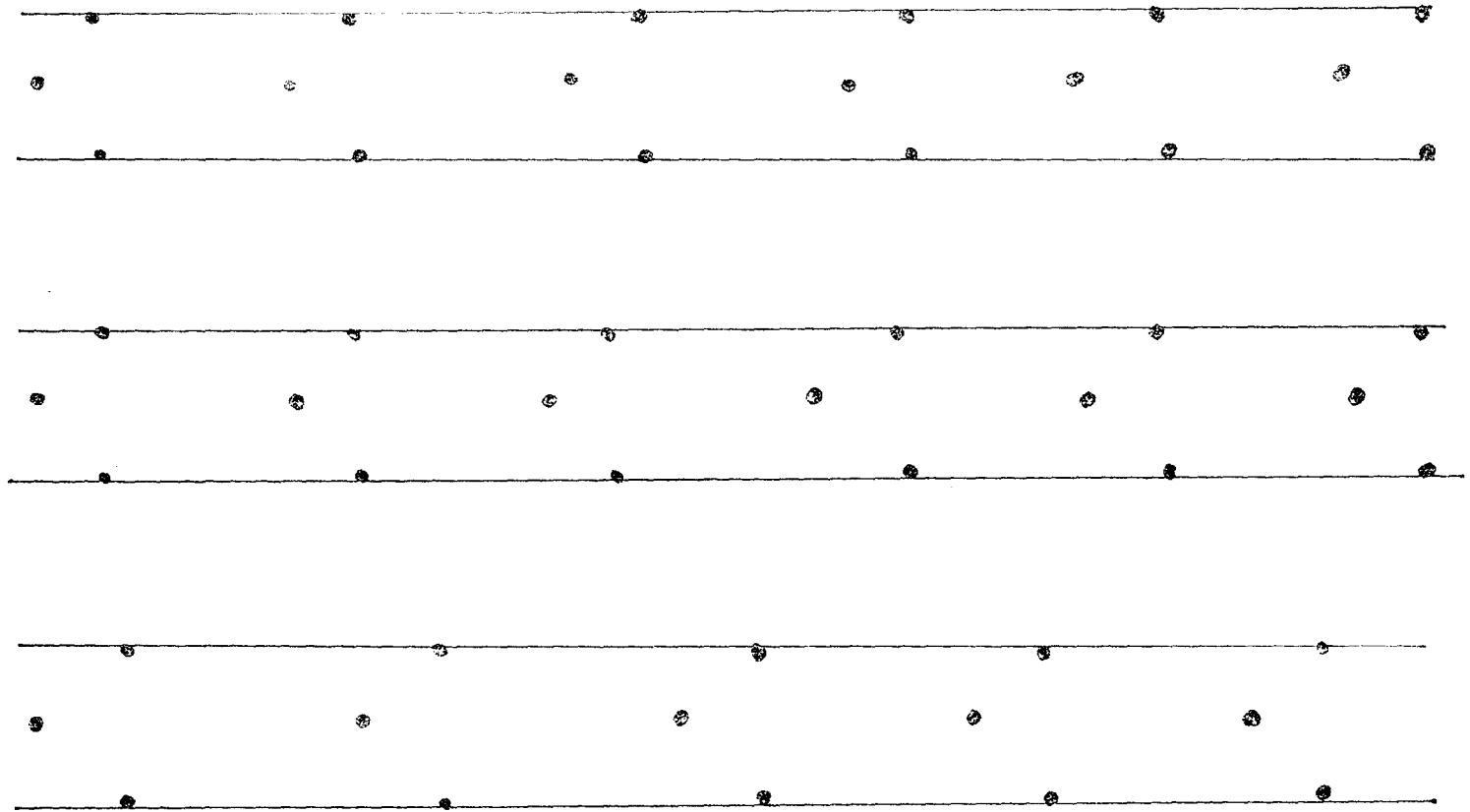
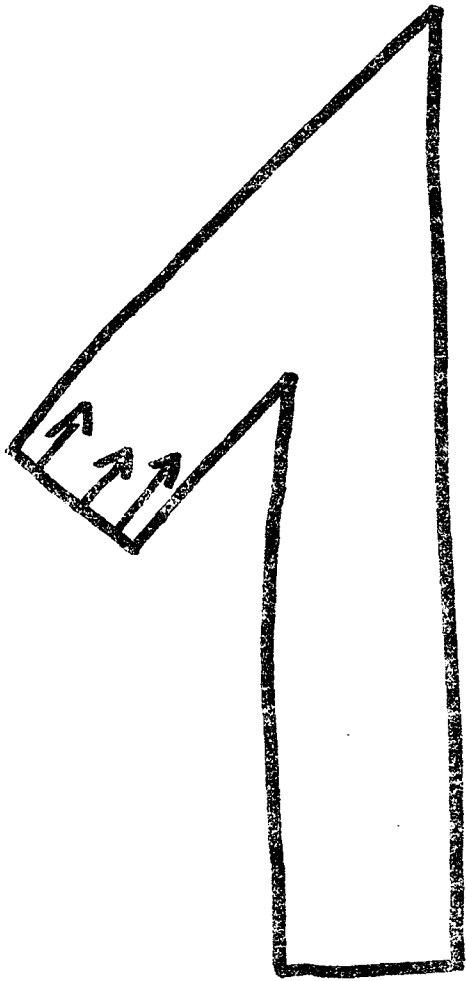

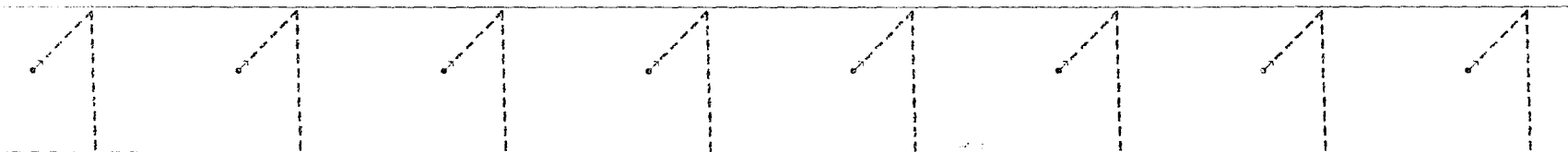
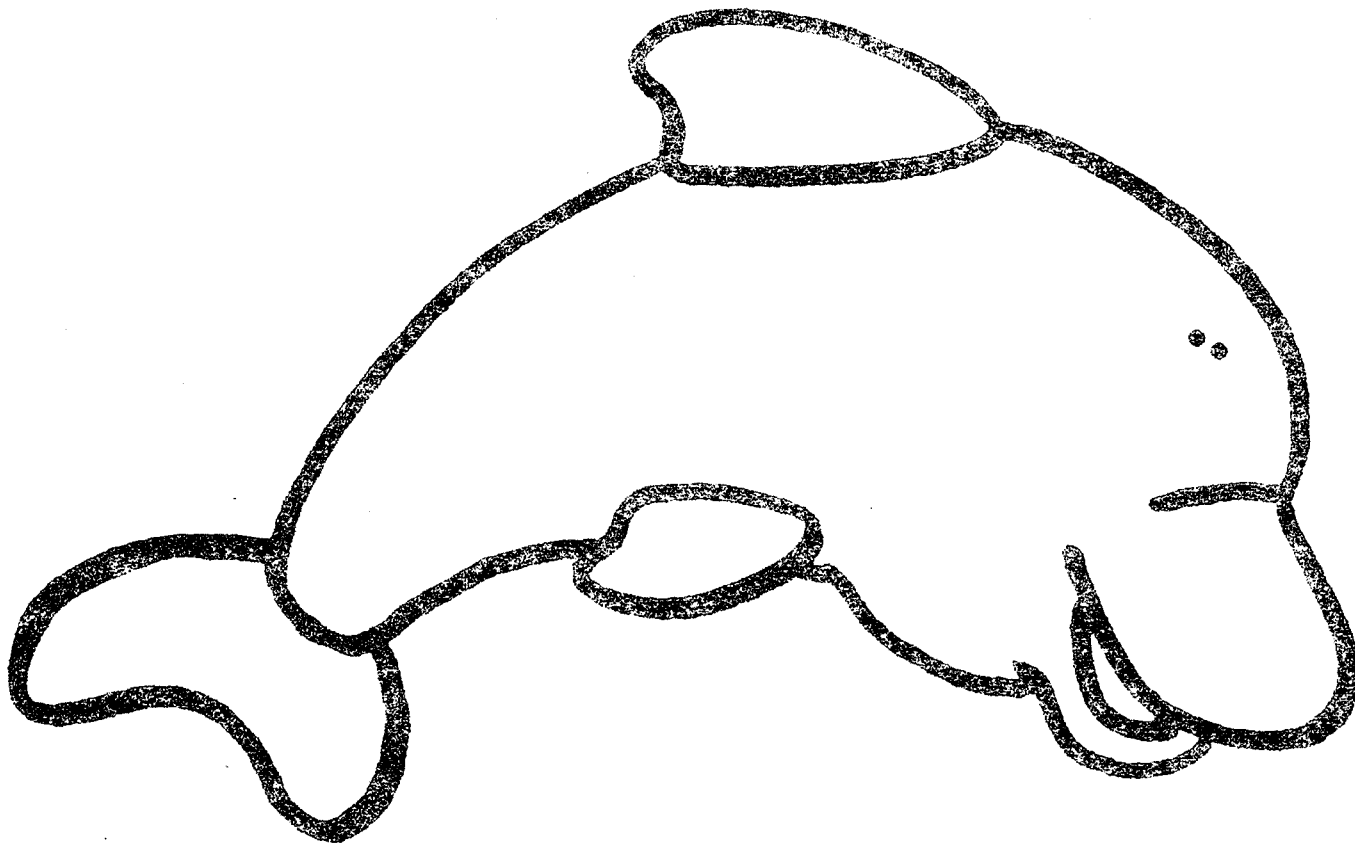

E.E.I. MAR DE ALBORÁN



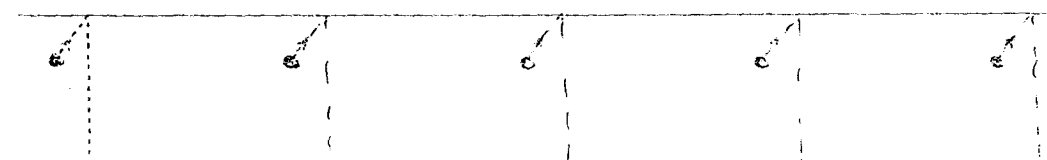
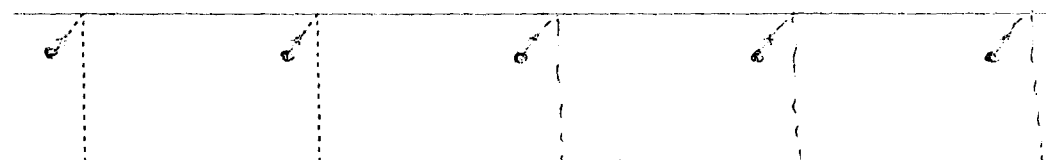
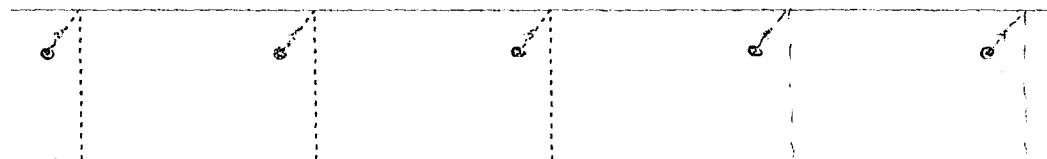
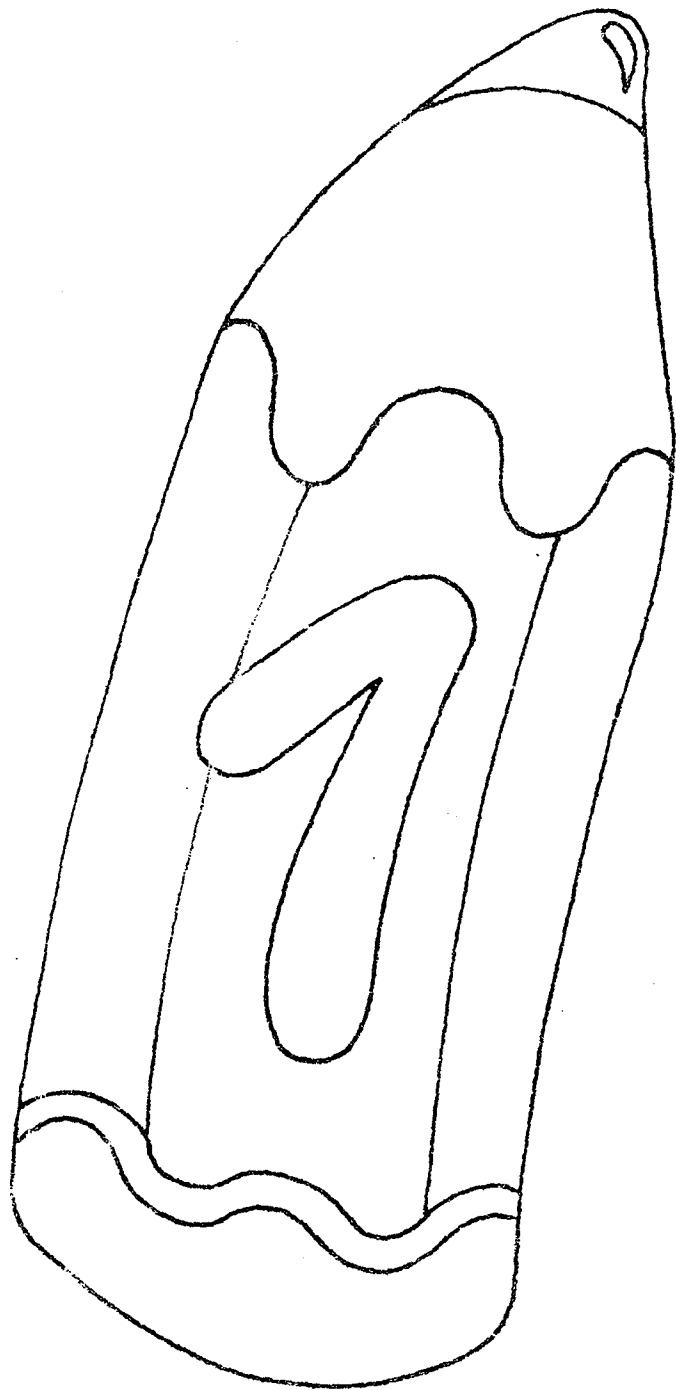

E.E.I. MAR DE ALBORÁN



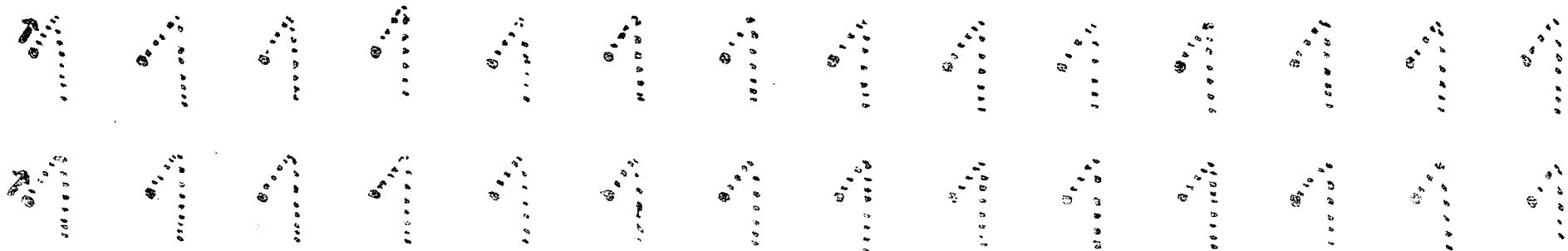
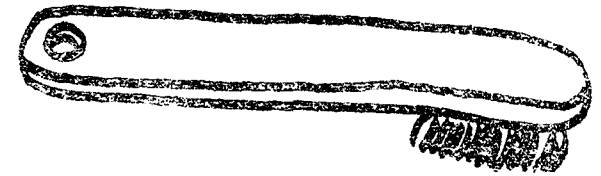
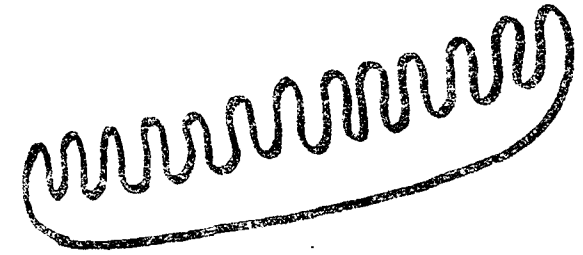
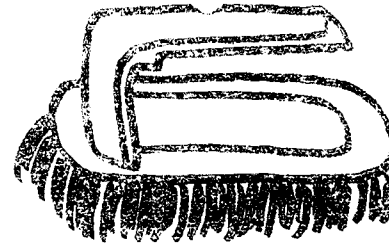
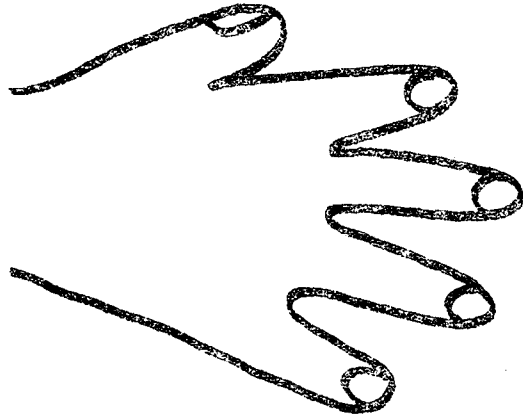

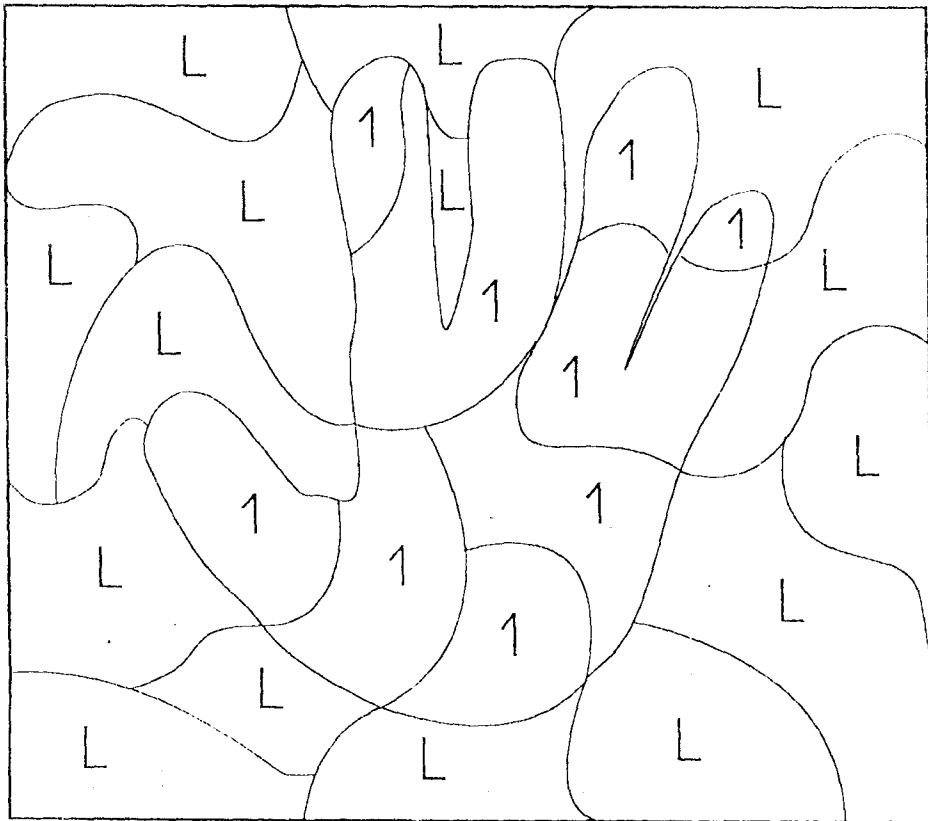

ROJO. 1

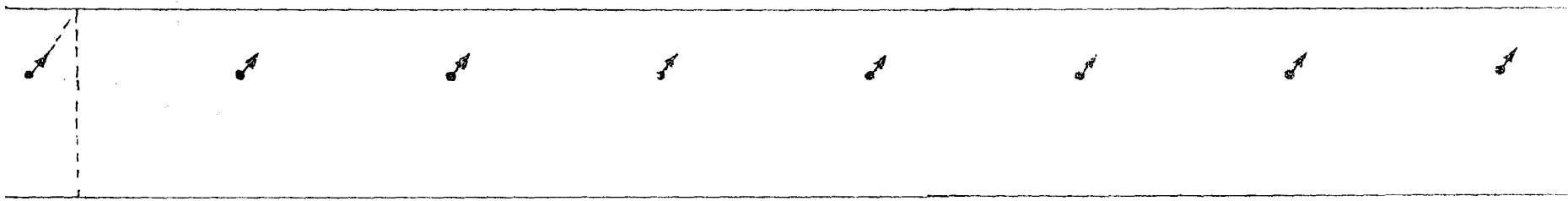
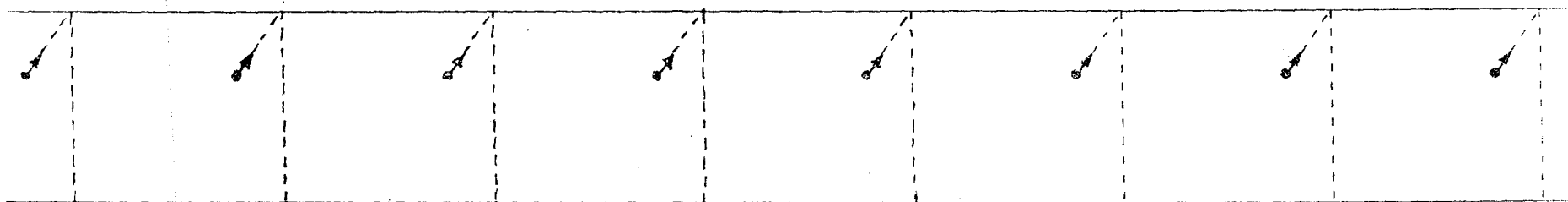
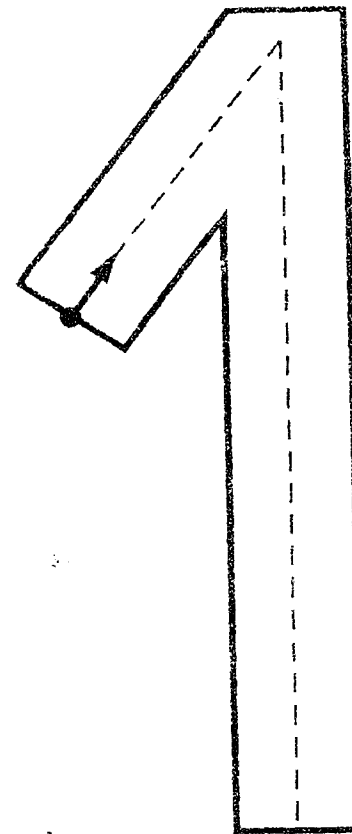

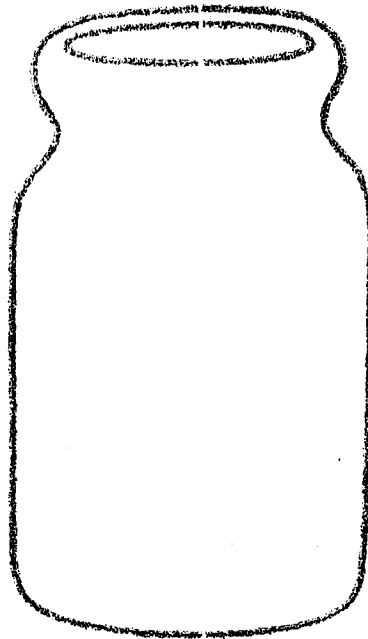
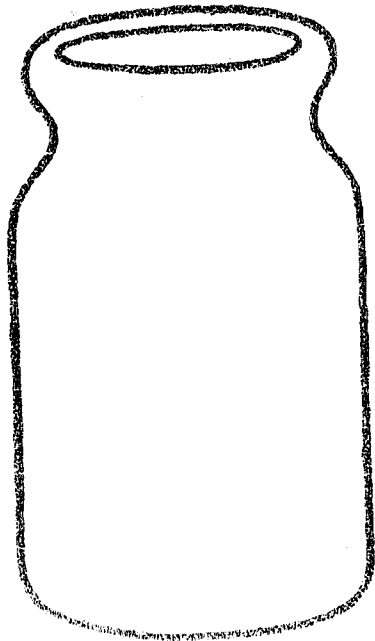

Dibujar un objeto o pegar un gomet en cada farro.

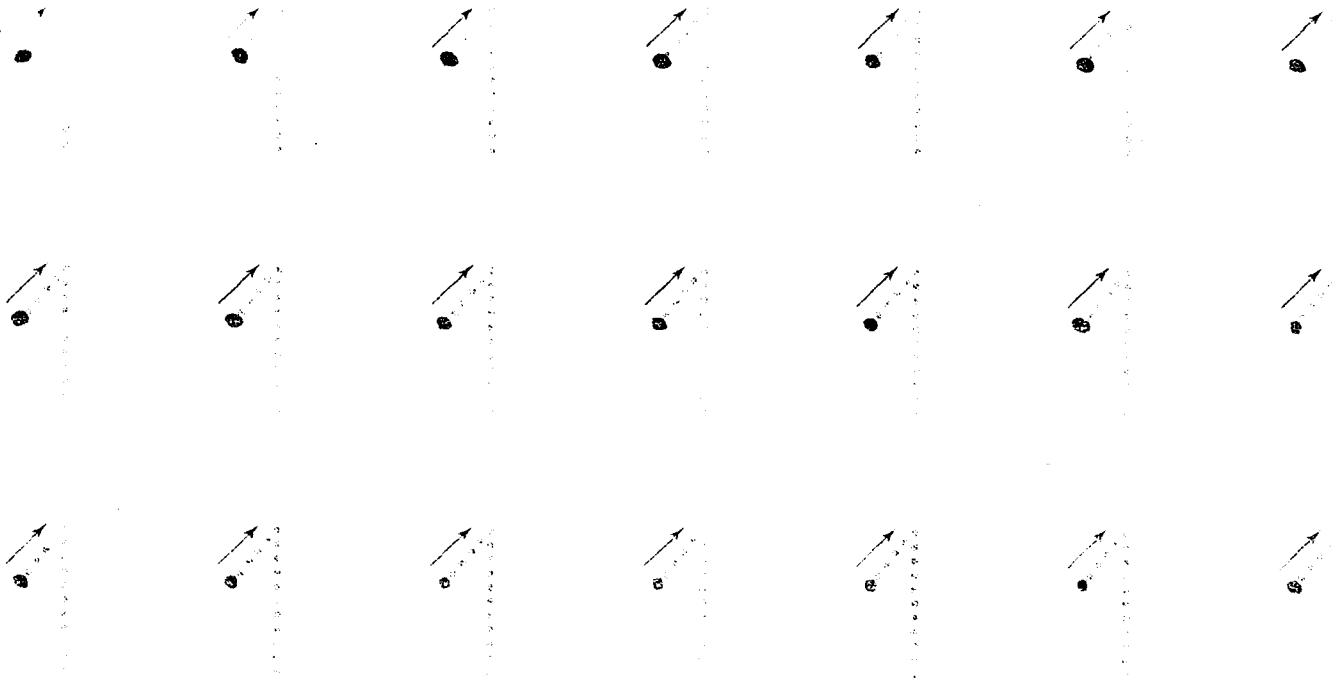
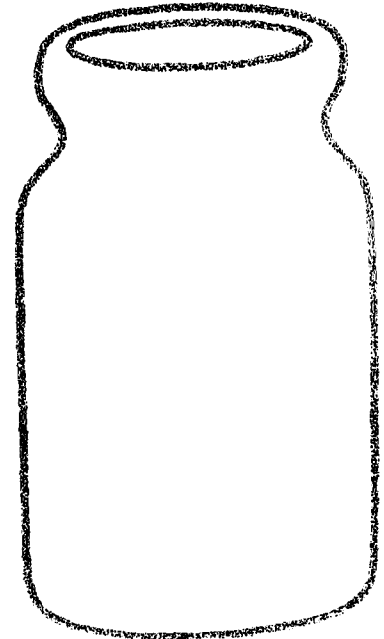



1

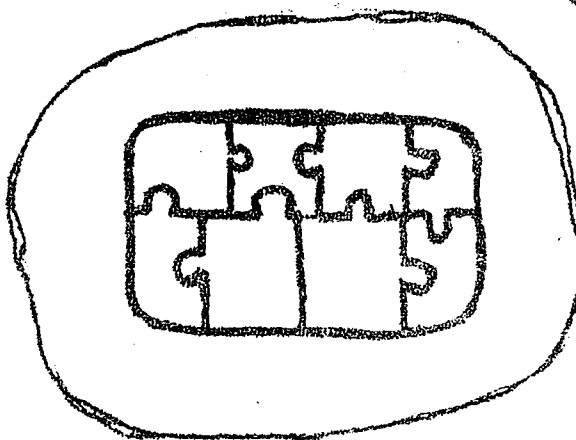
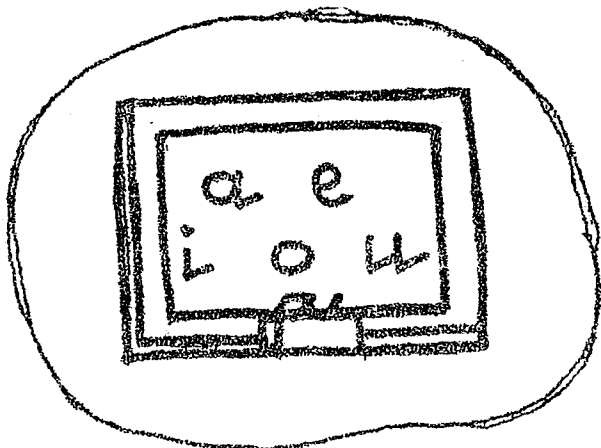
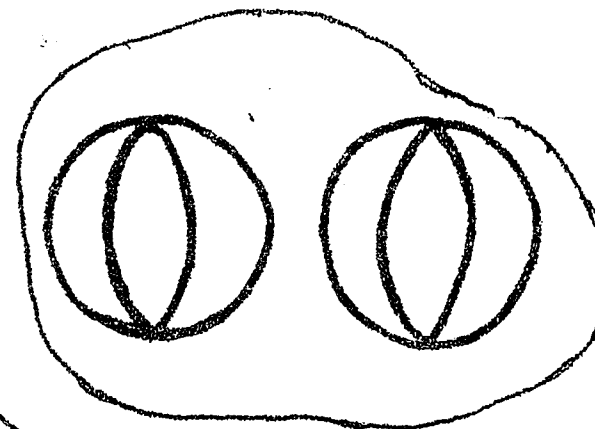
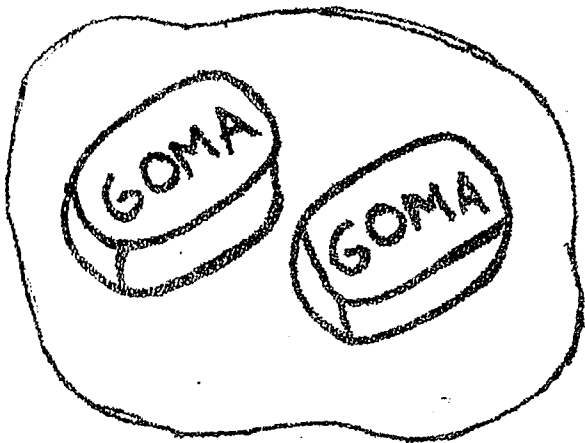
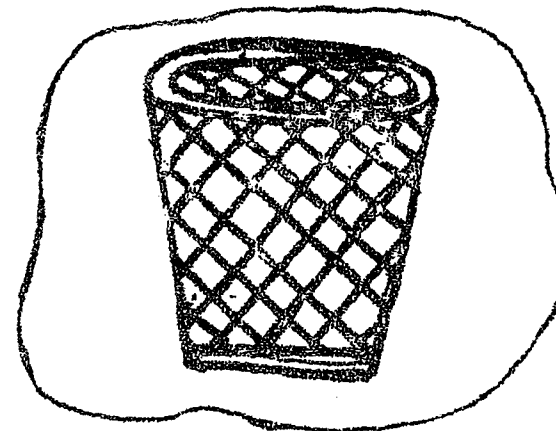

El número 1.

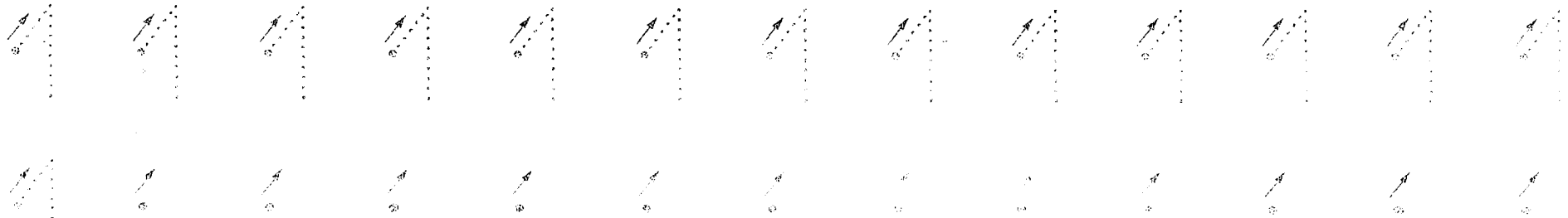
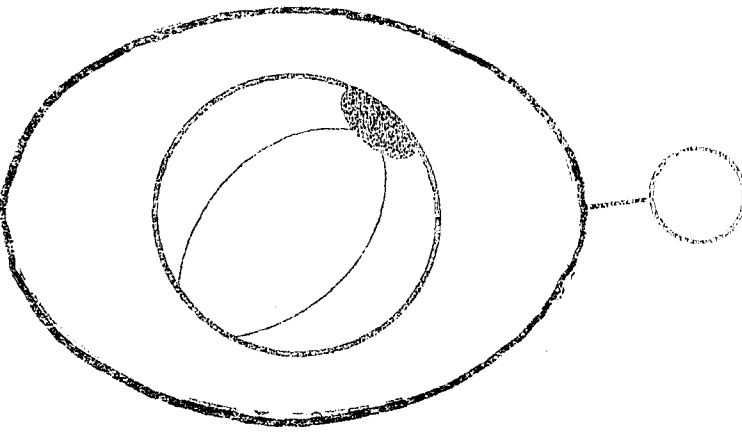
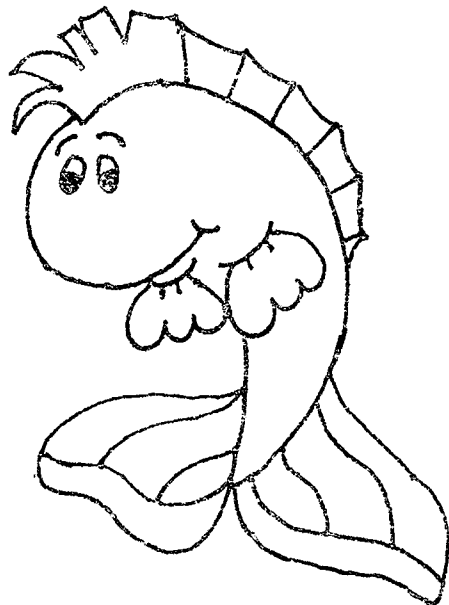
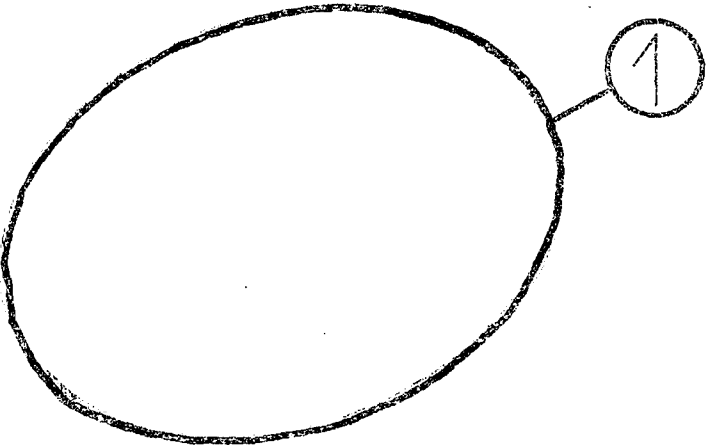
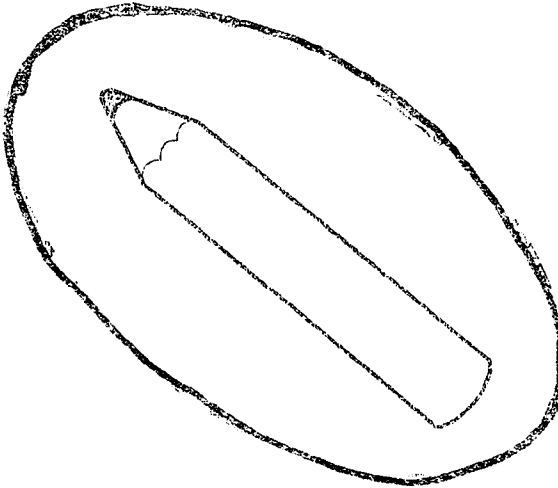
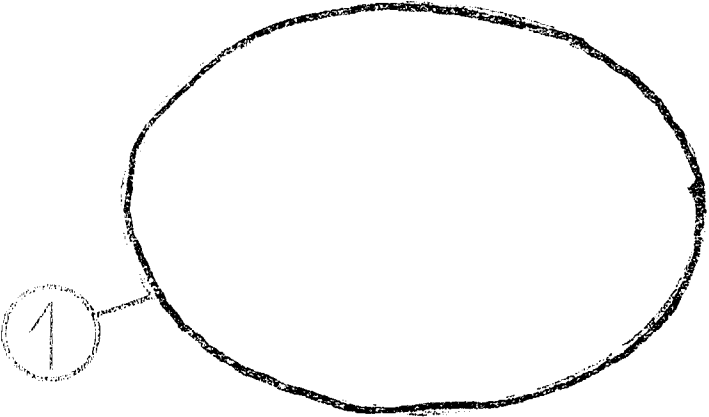

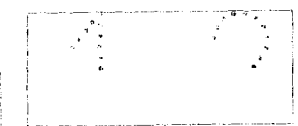
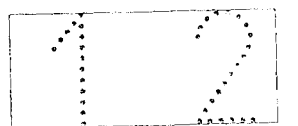
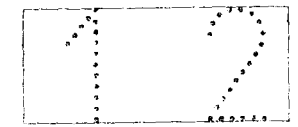
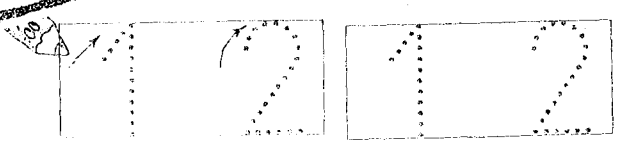
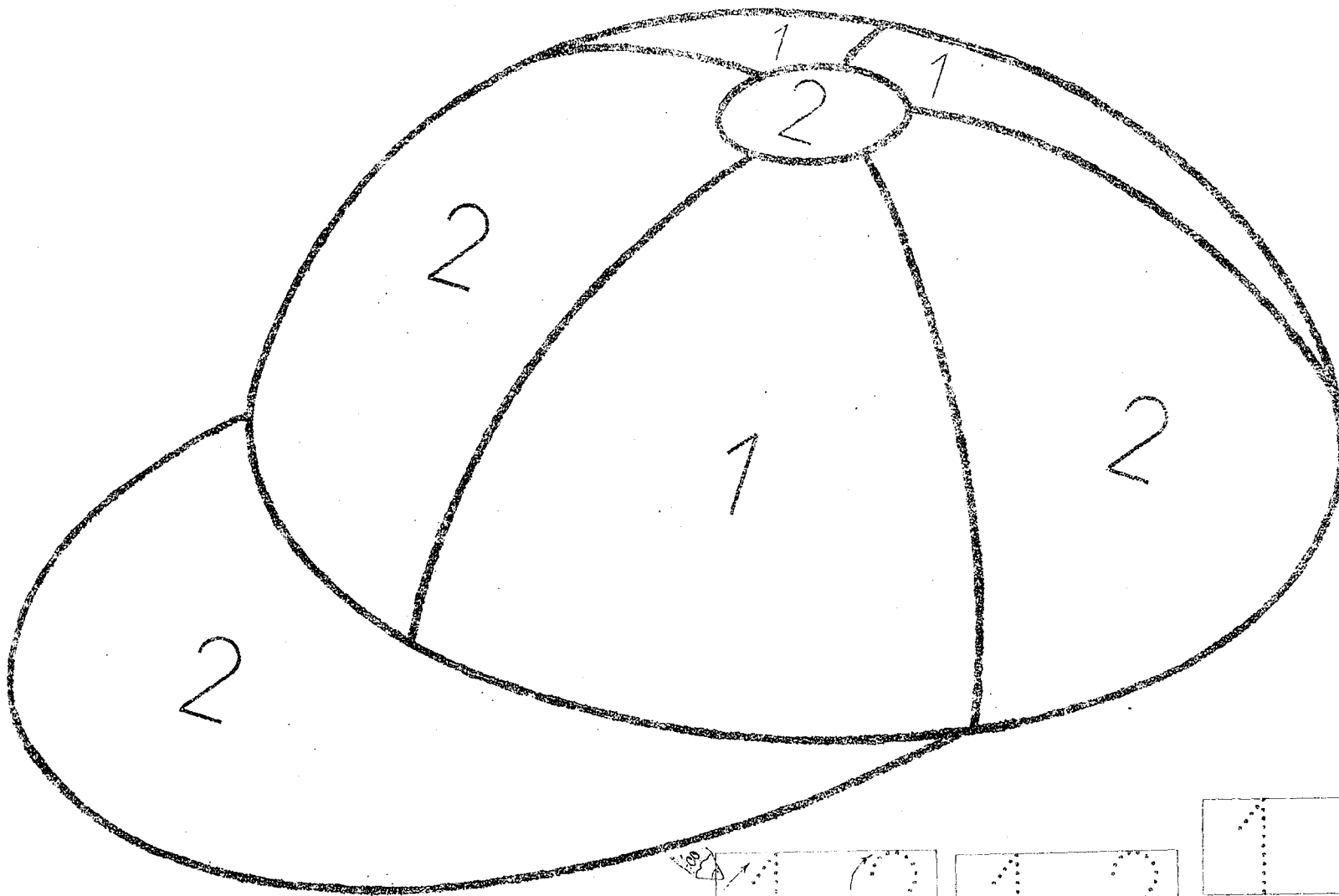

E.E.I. MAR DE ALBORÁN

El número 2

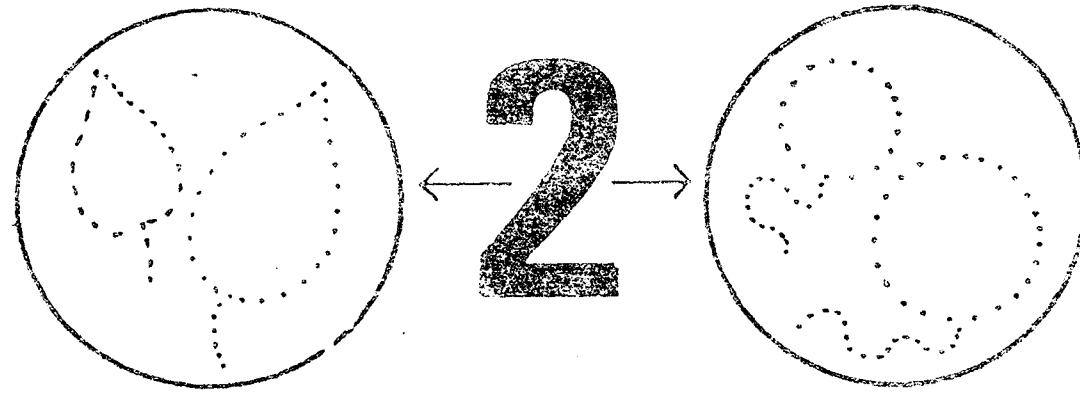

- Repasar con el lápiz los dos elementos de cada conjunto.

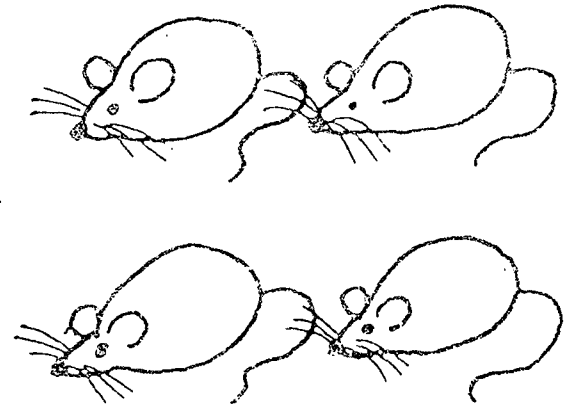
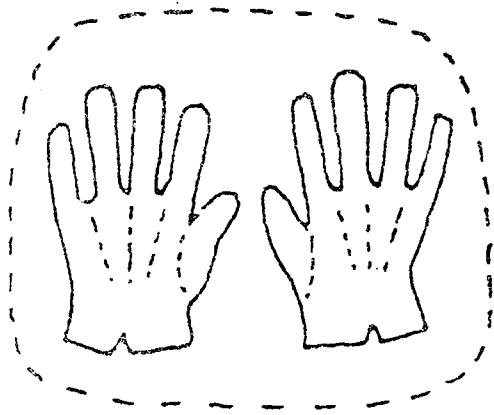

- Rodear y colorear dos elementos.



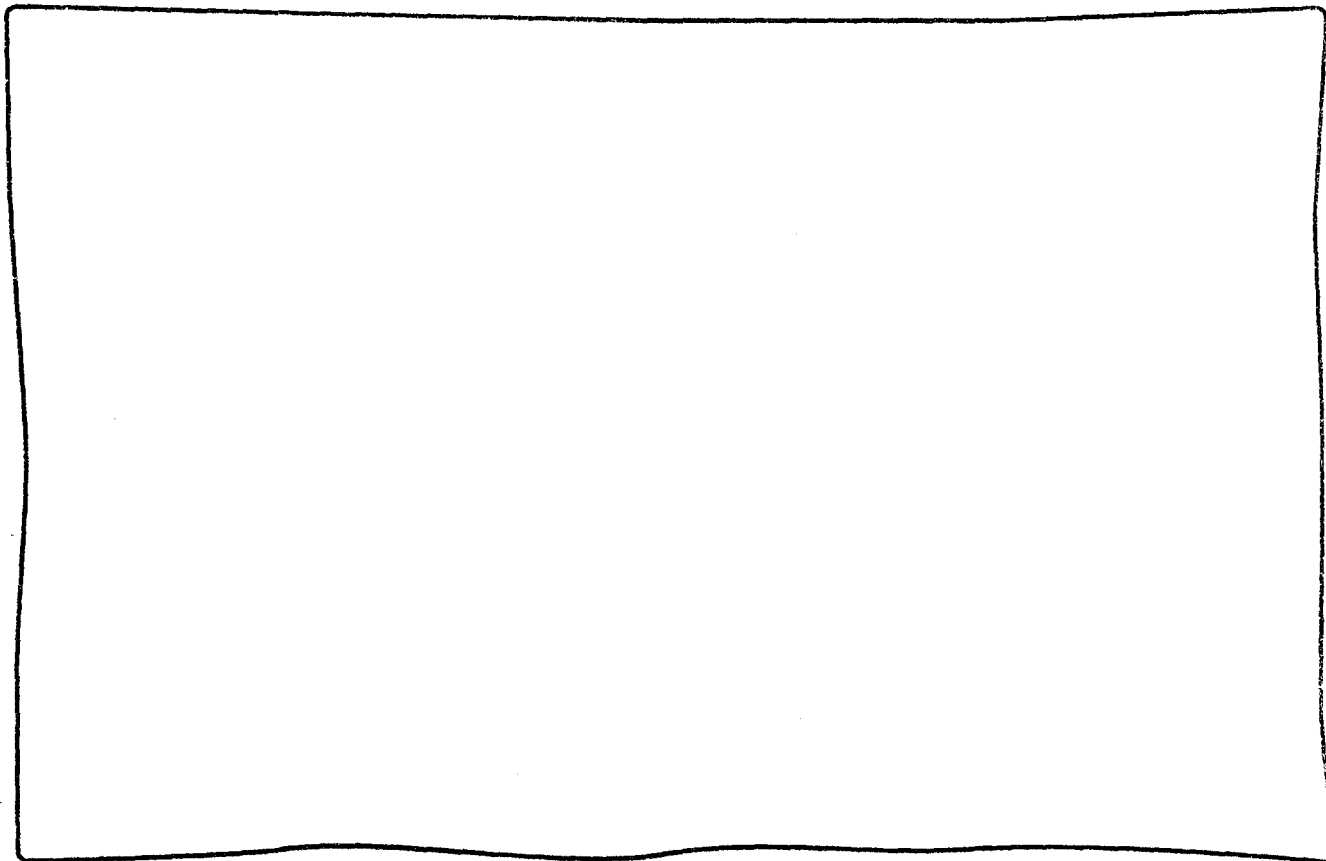
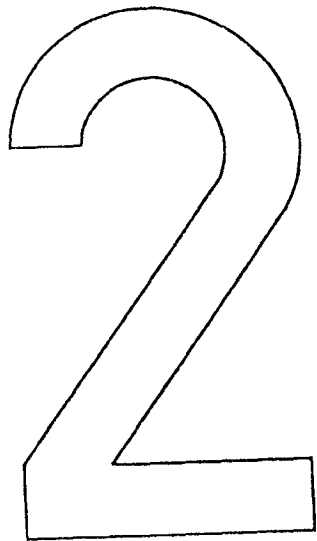

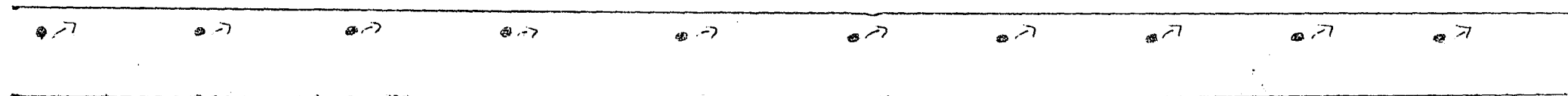
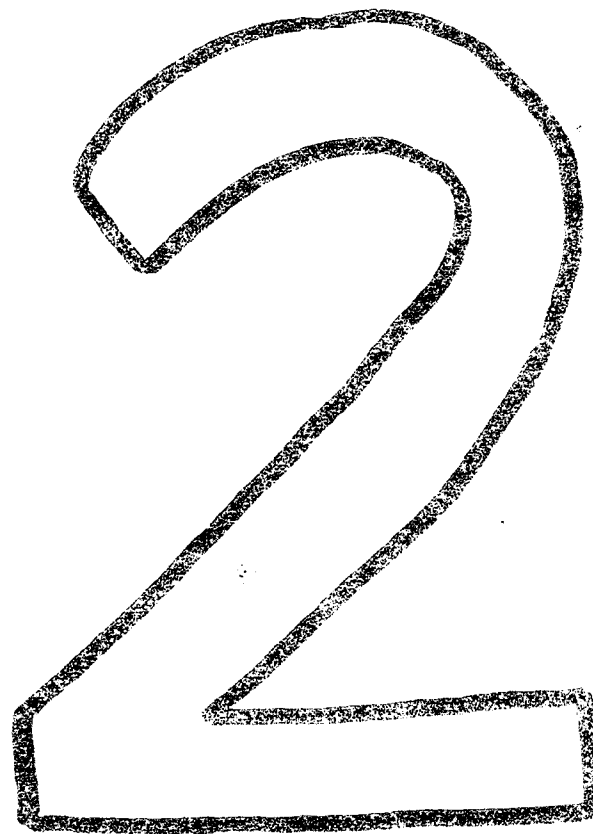
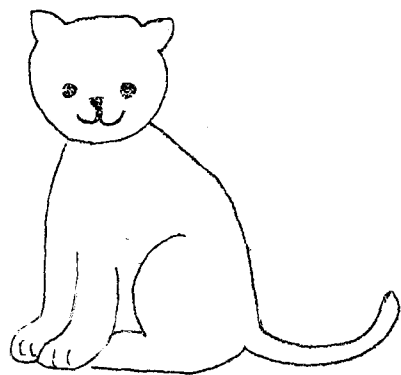
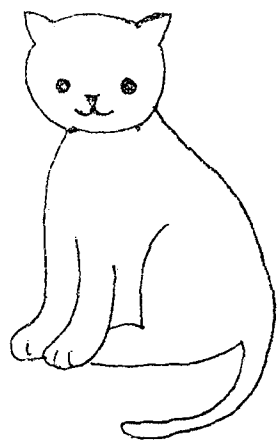

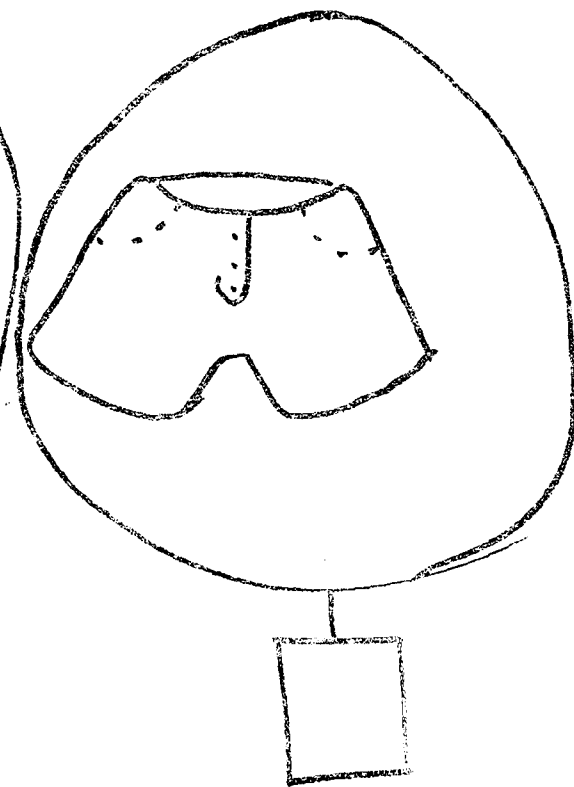
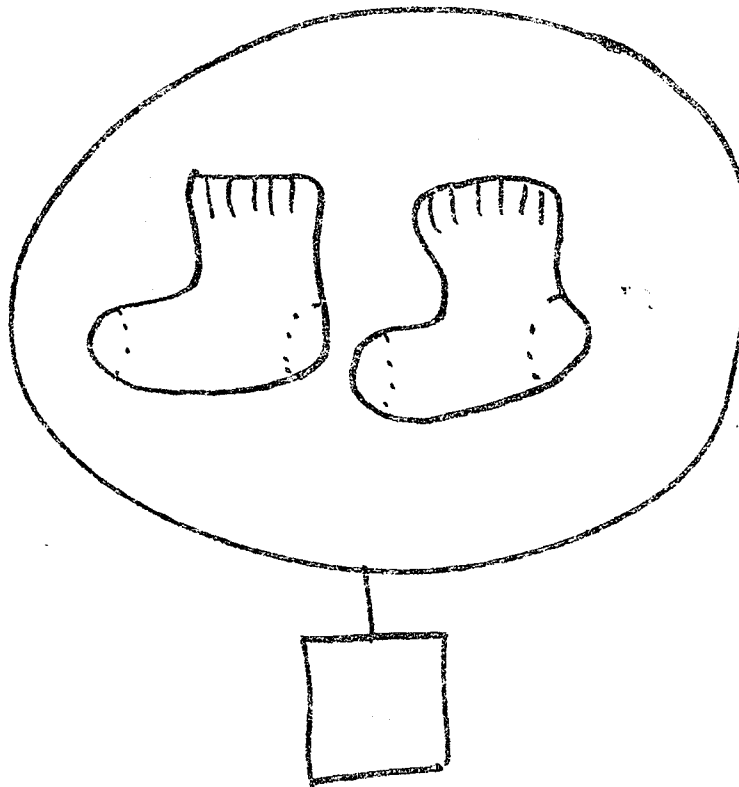
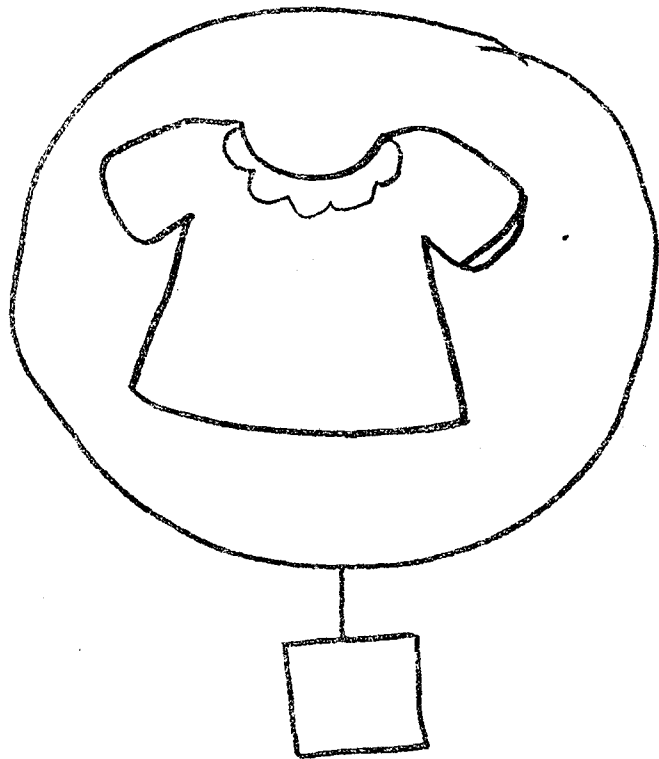

1



2



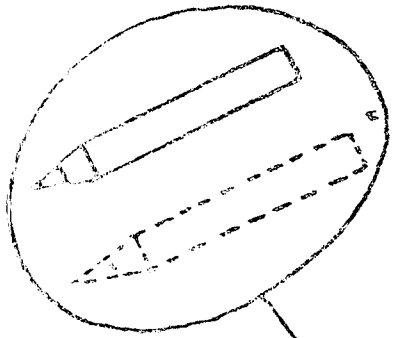

2

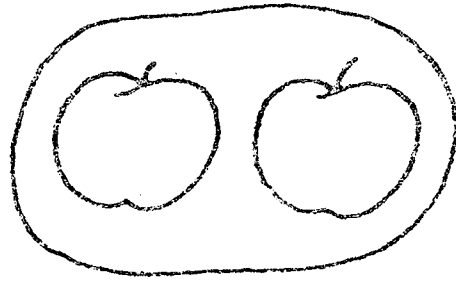

2

dos

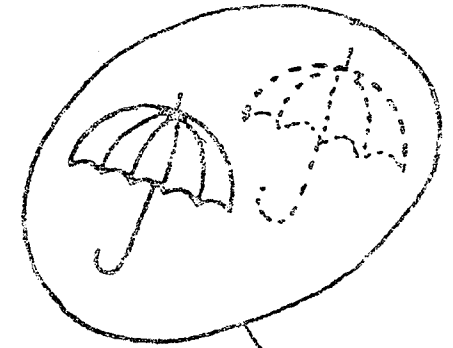

2

2 2 2 2 2 2 2 2 2
2 2 _ _ _ _ _

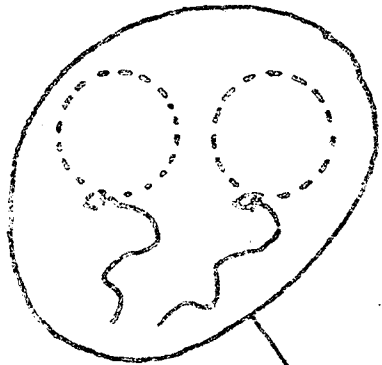

2

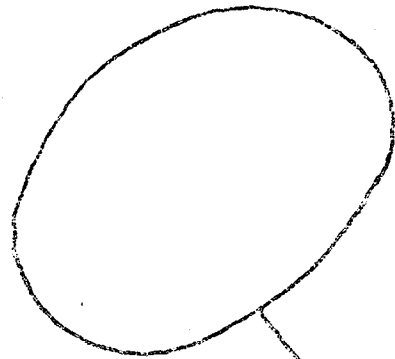

2

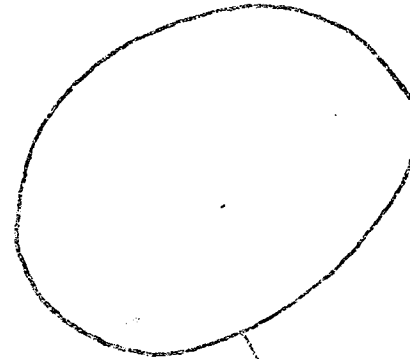

2

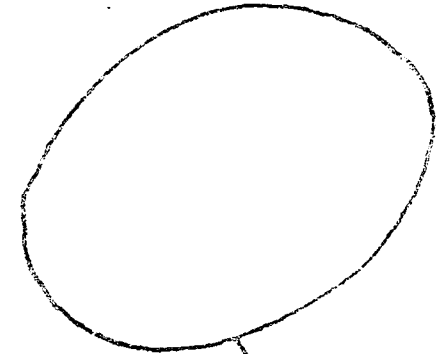

2

Repasar con el lápiz, o dibujar, los elementos que faltan en cada conjunto.



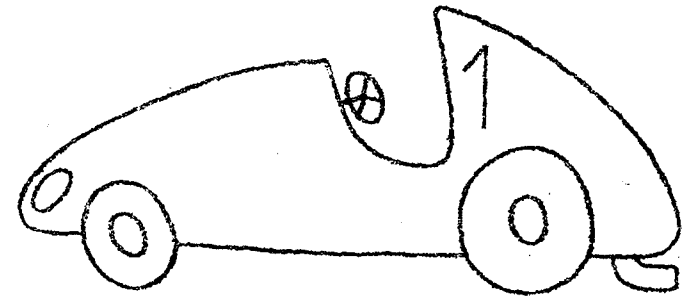
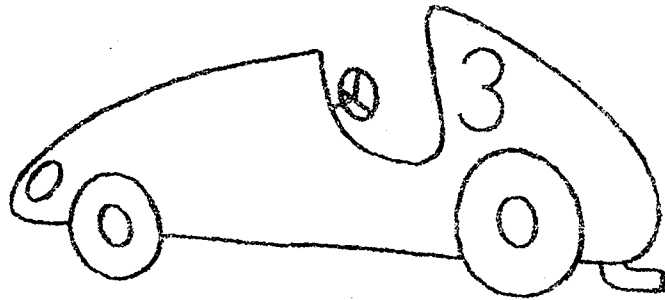
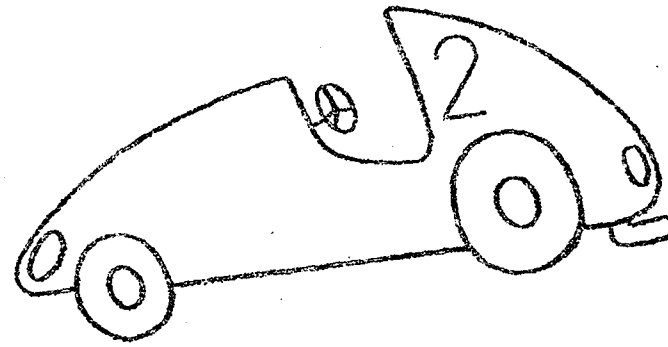
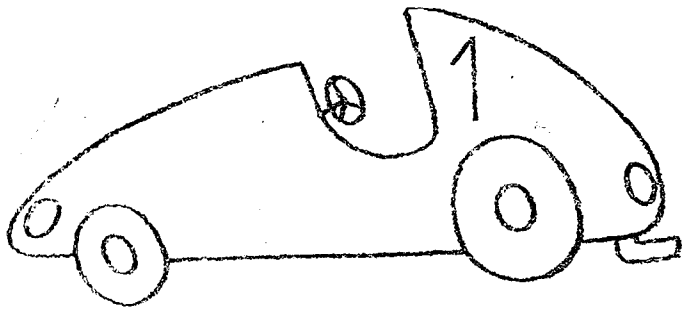

COLOREA LOS COCHES QUE TIENEN EL N.º 1. REPASA

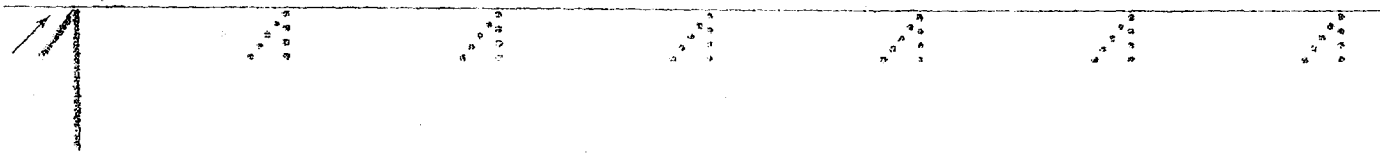
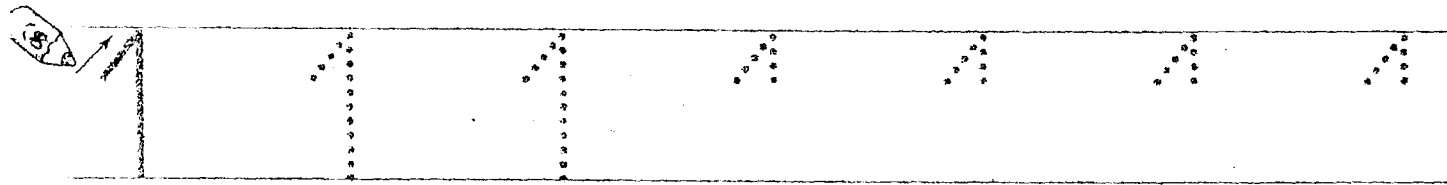

Cantidad

- ✓ Hacer de diferentes colores, el número tres dentro de su silueta.
- ✓ Contar los peces y colorear sólo tres.

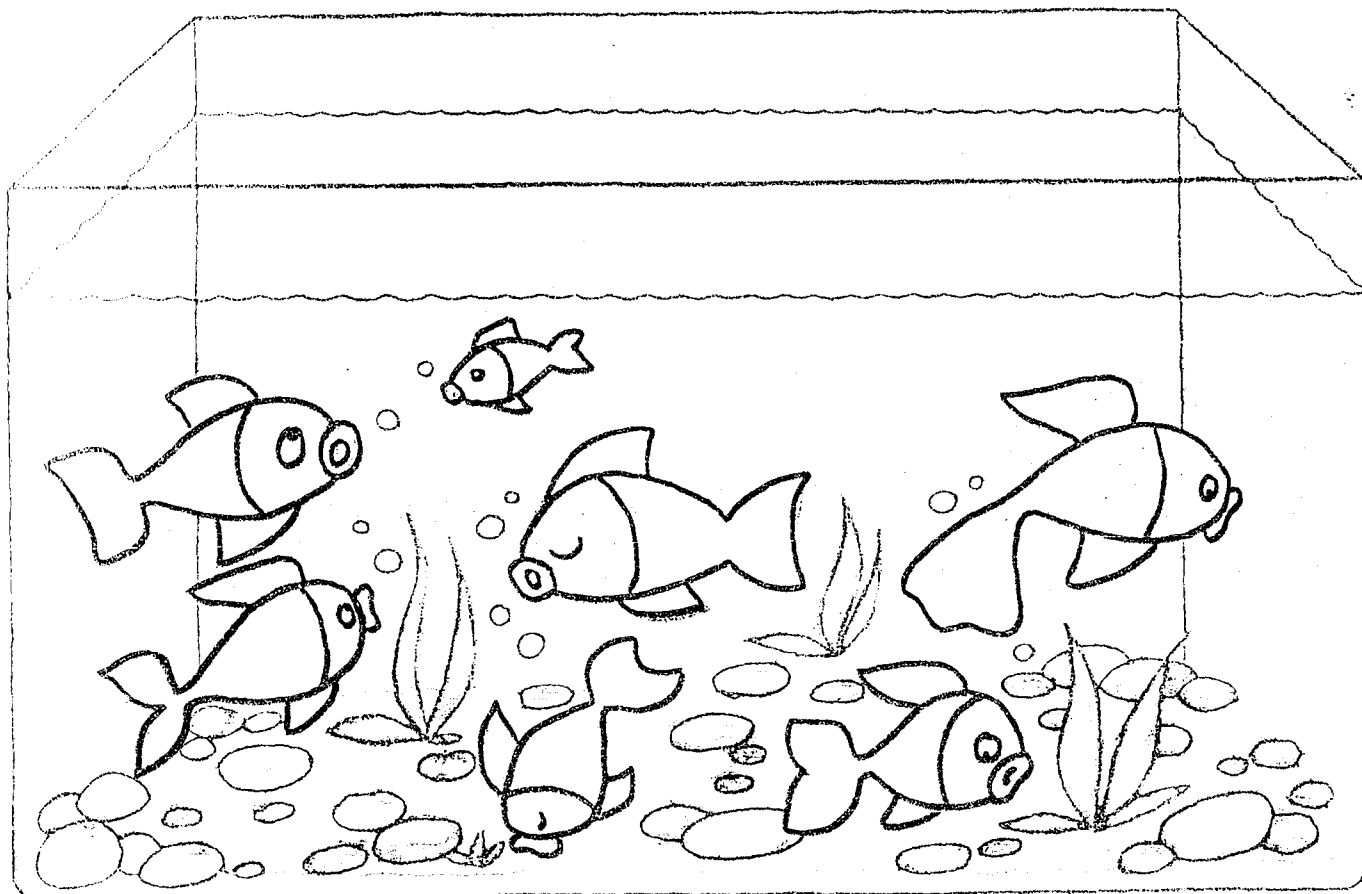
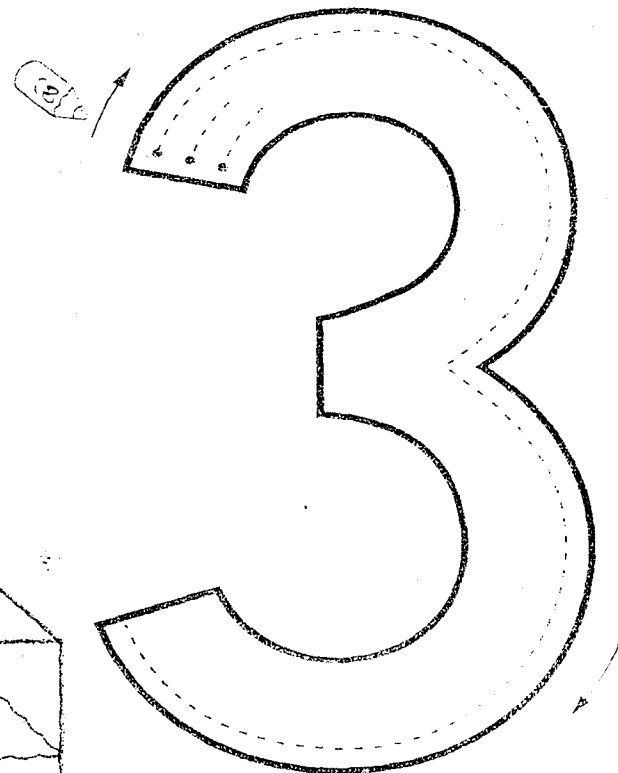

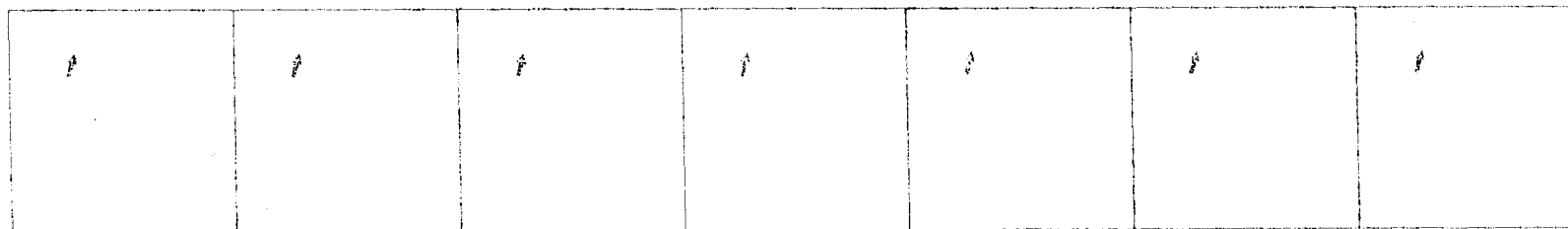
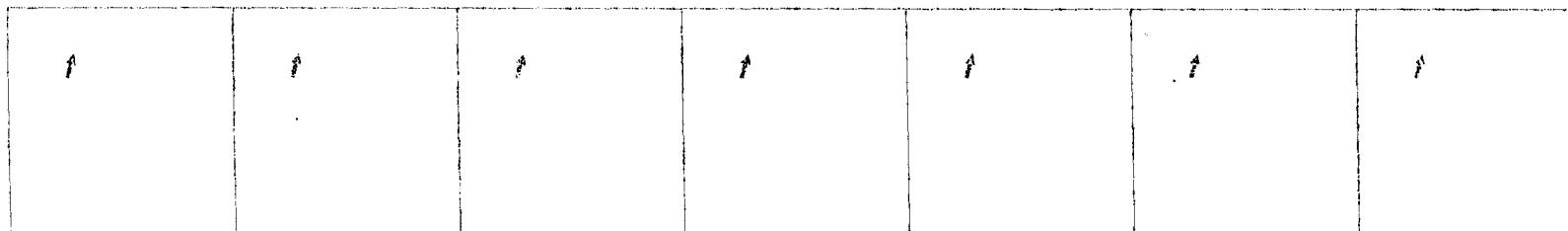
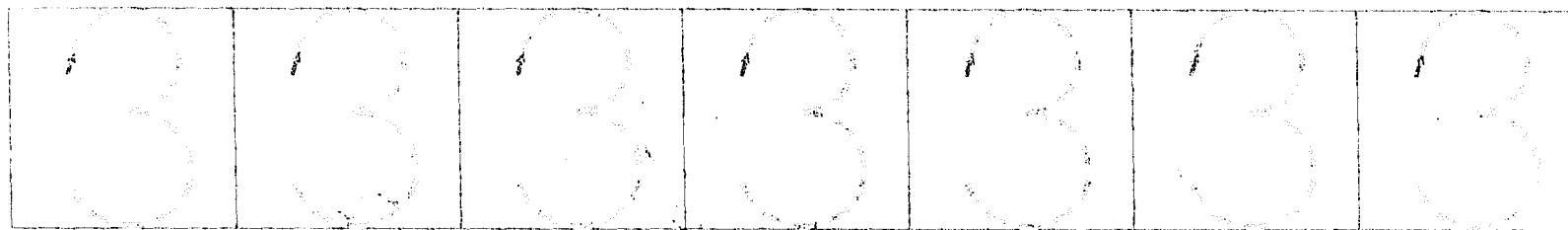
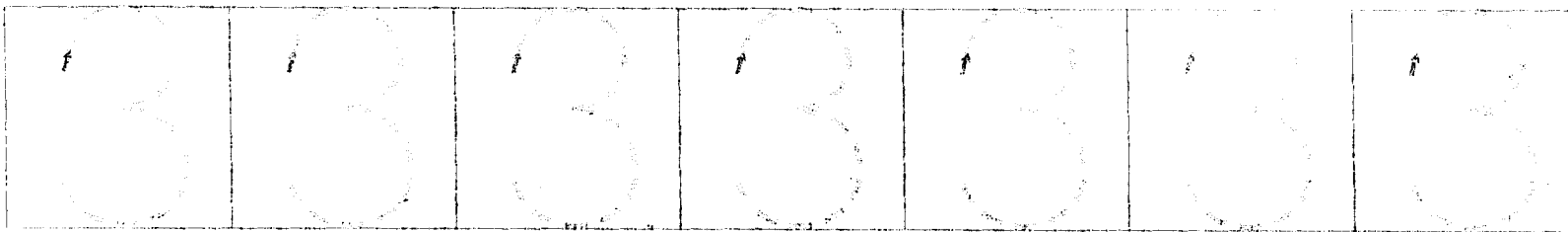

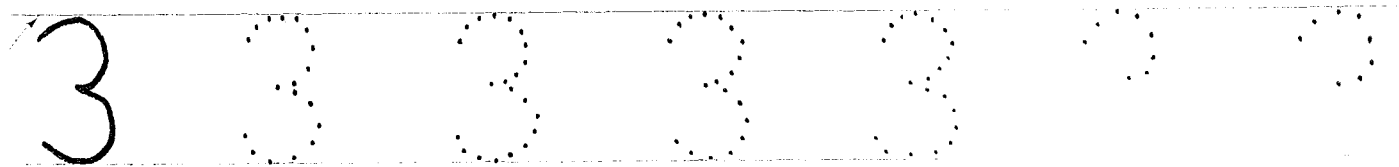
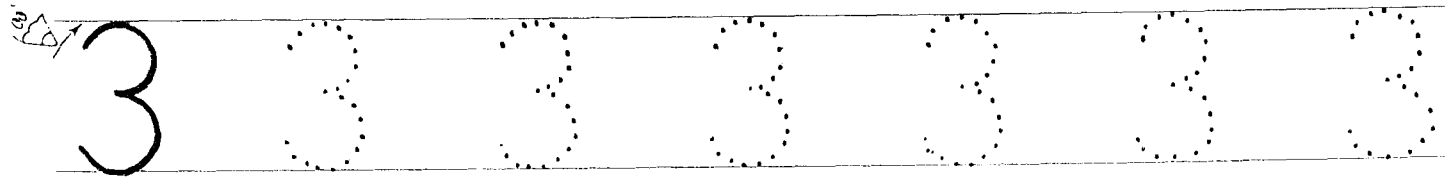
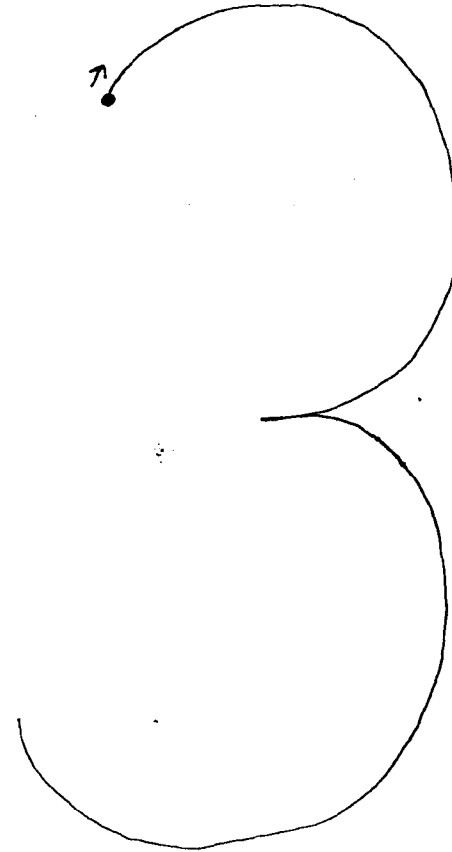
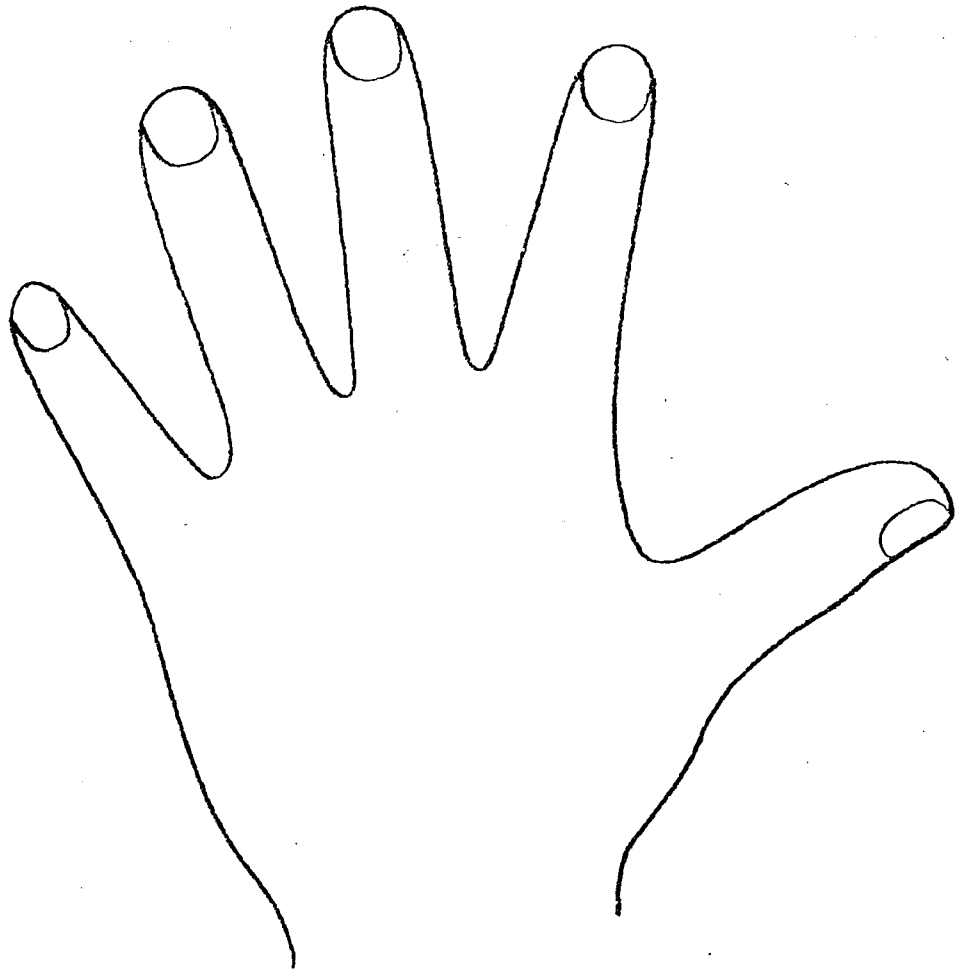

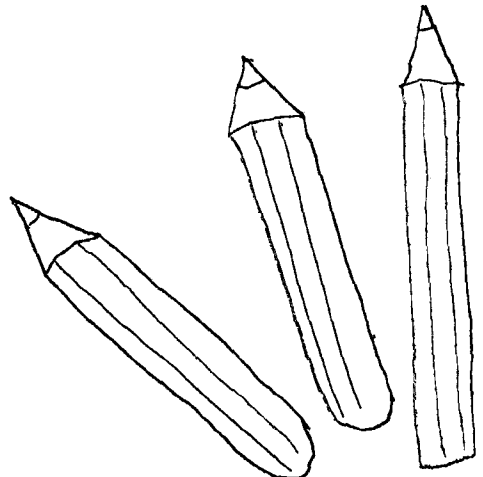
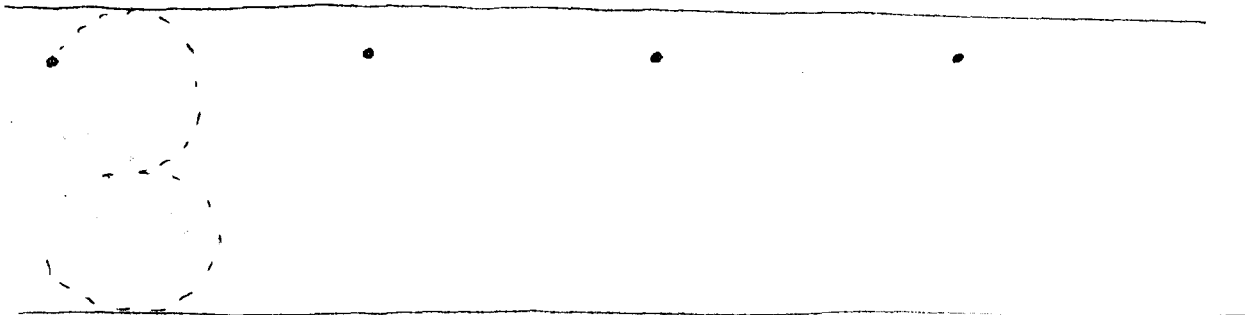
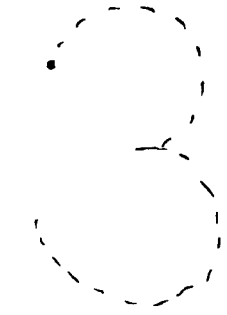
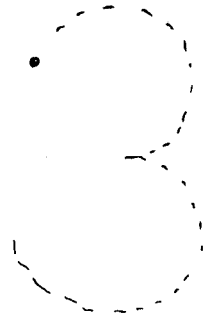
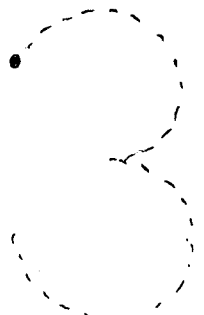
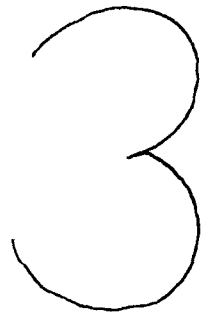

Cuenta, rodea y escribe:

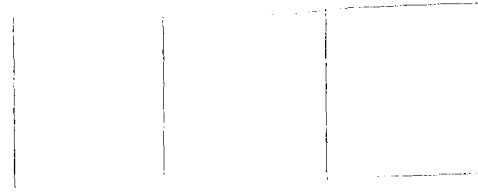
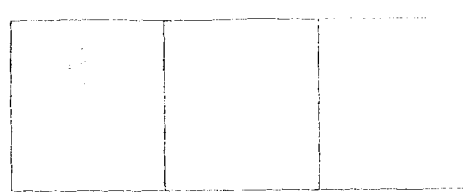
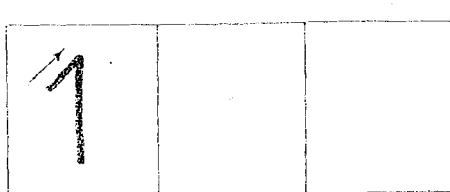
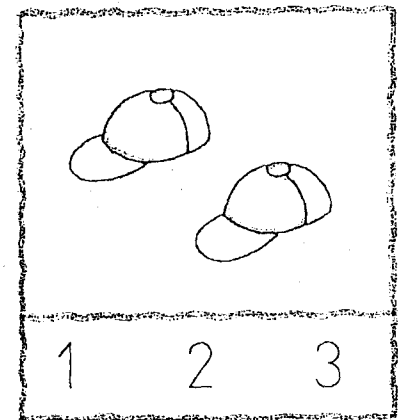
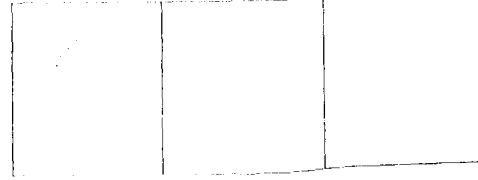
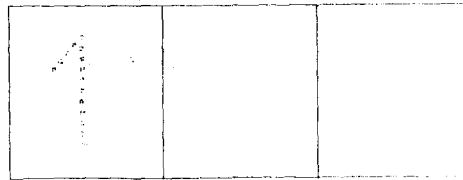
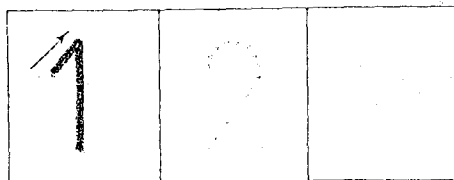
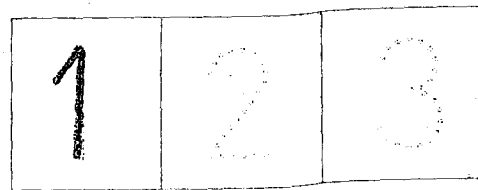
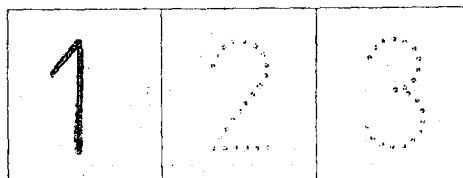
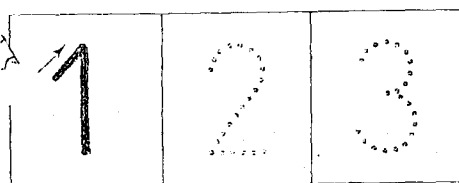
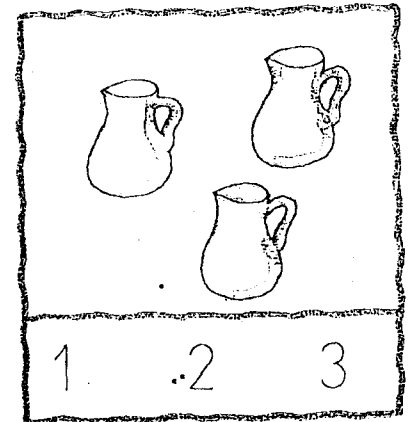
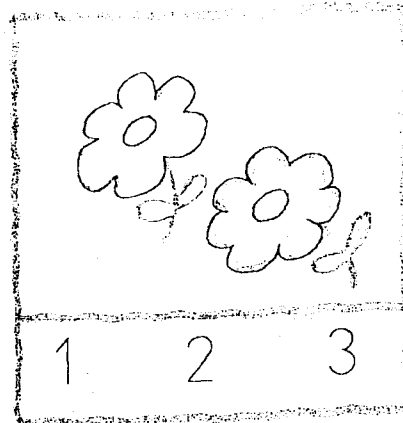
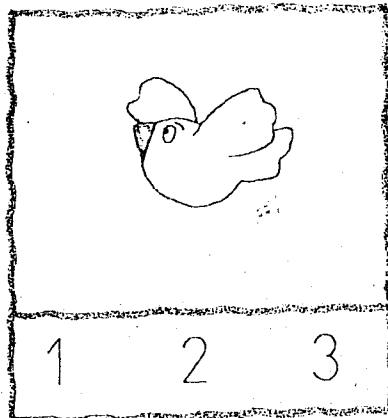
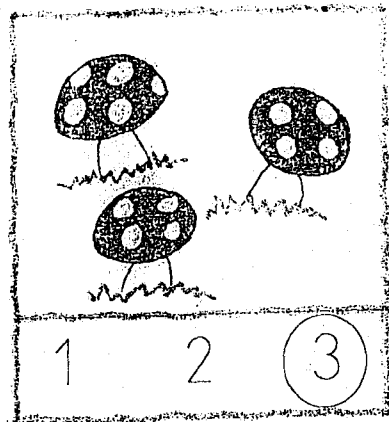

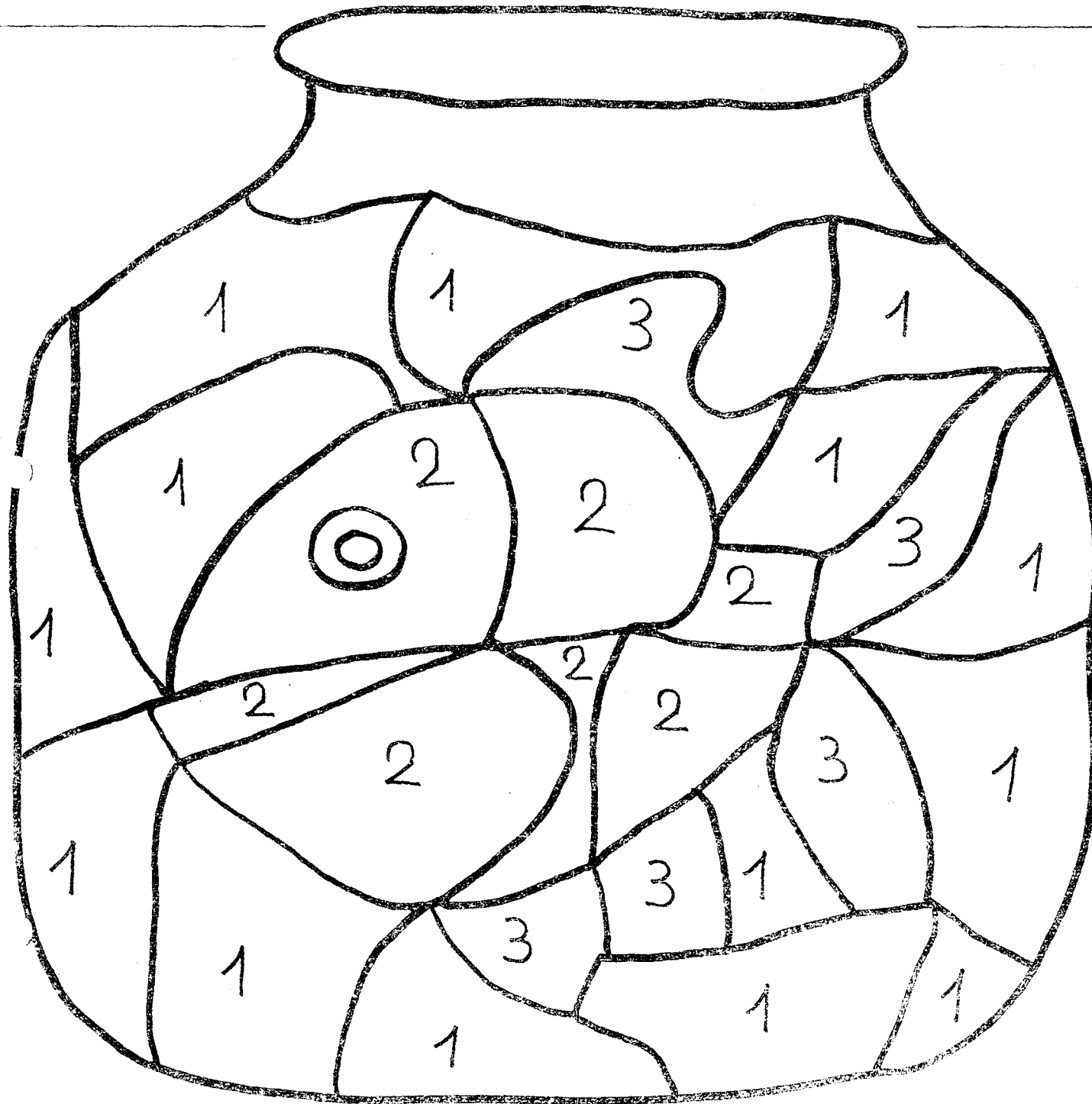

Colorea:

1 → azul

2 → amarillo

3 → rojo



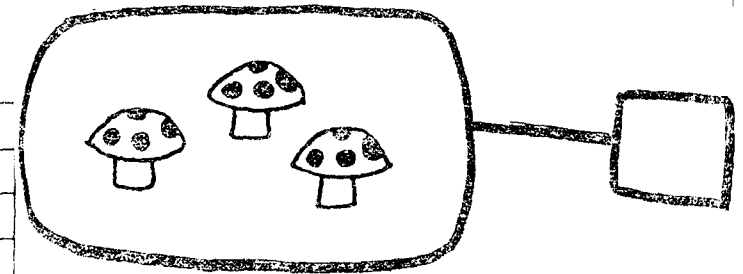
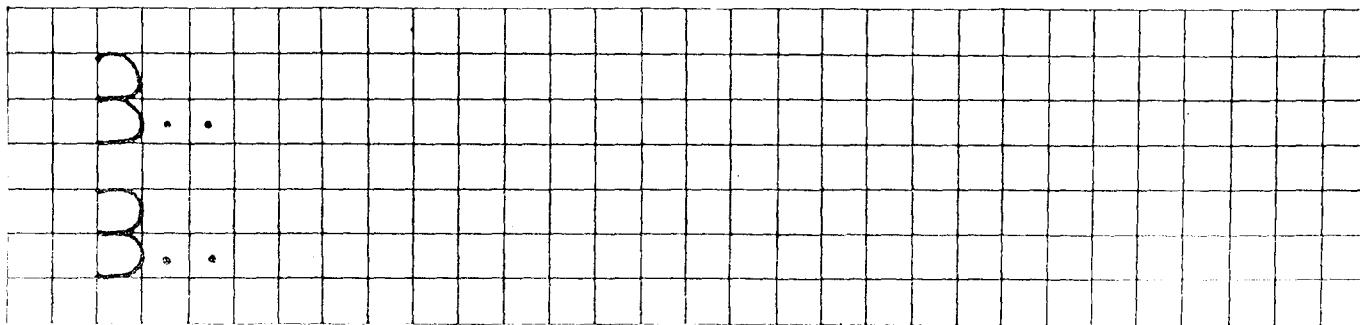
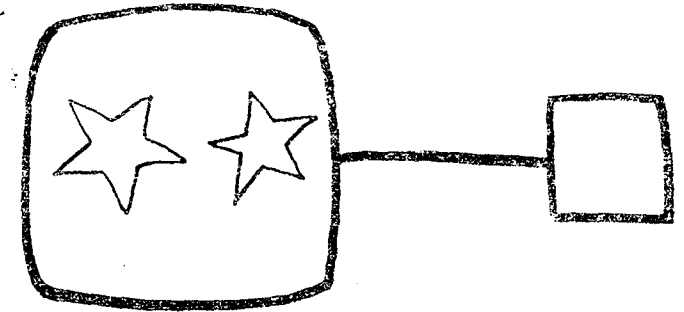
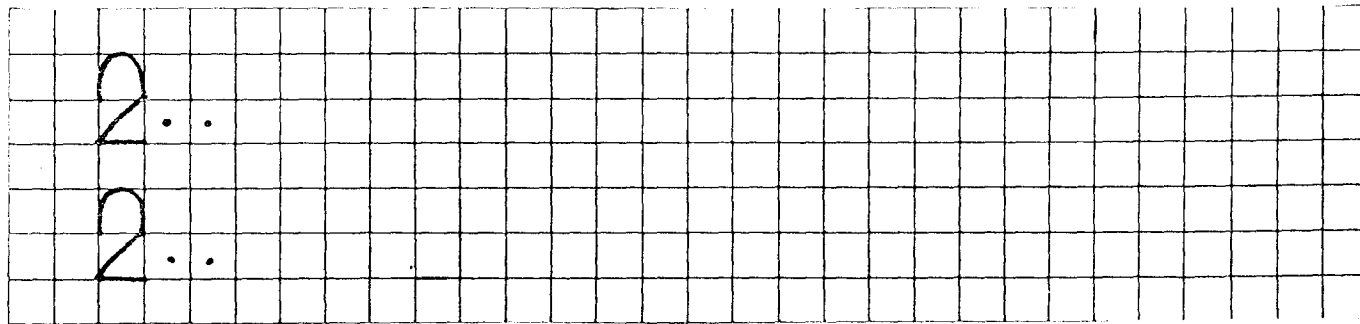
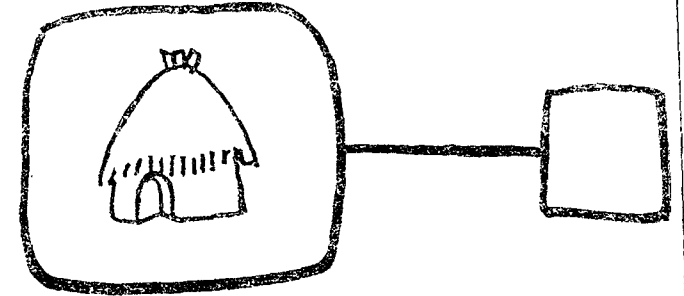
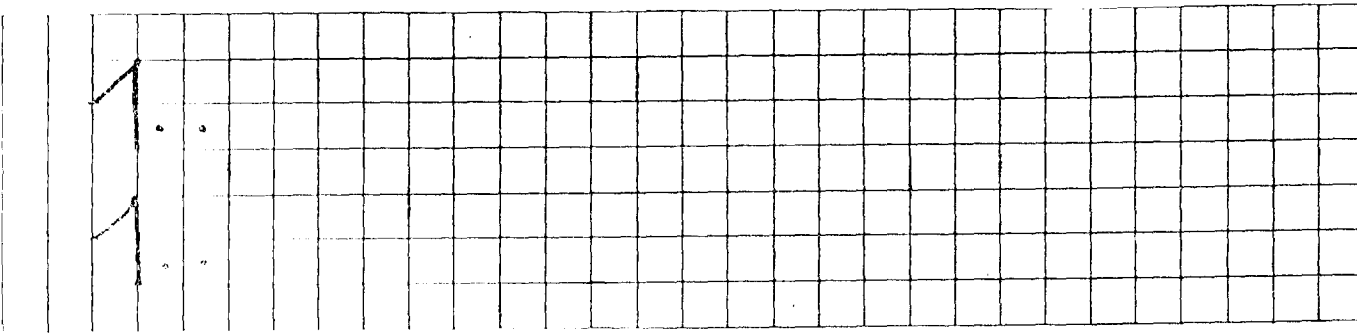

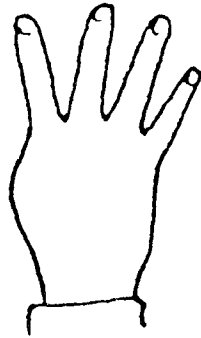
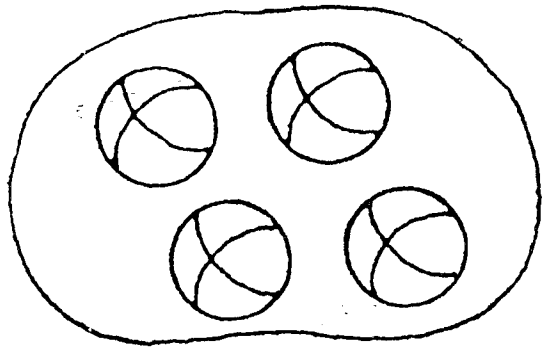
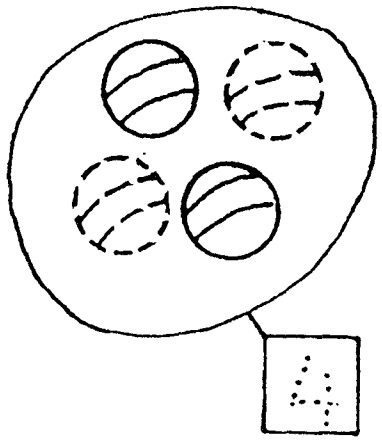

4

cuatro

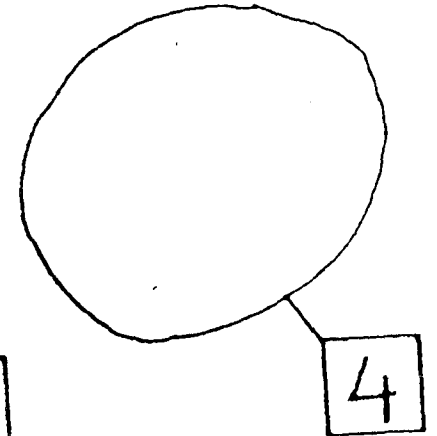
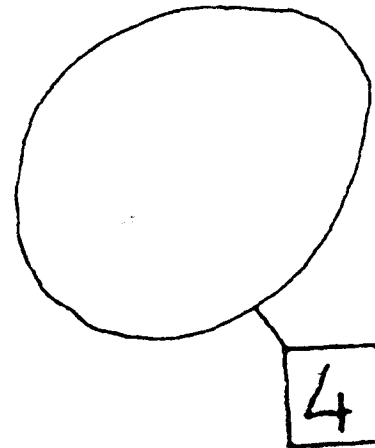
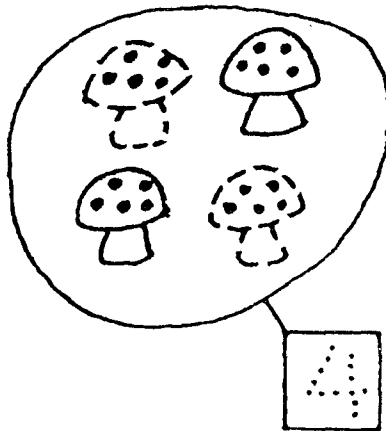
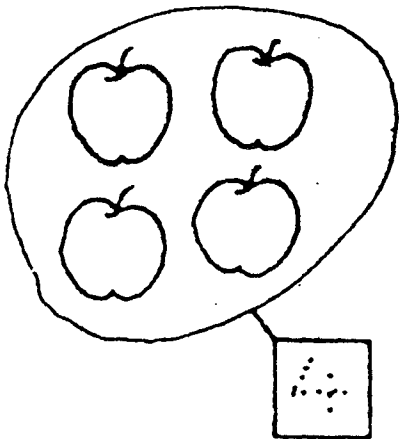
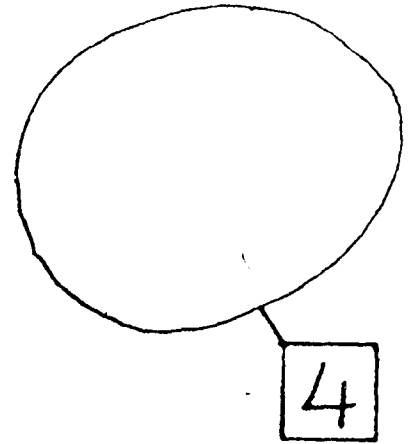

4 4 4 4 4 4 4 4 4 4

4 4 _ _ _ _ _ _ _



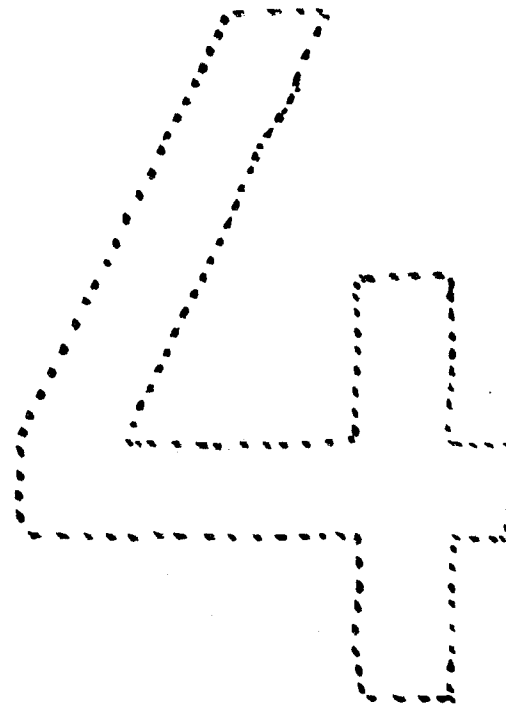
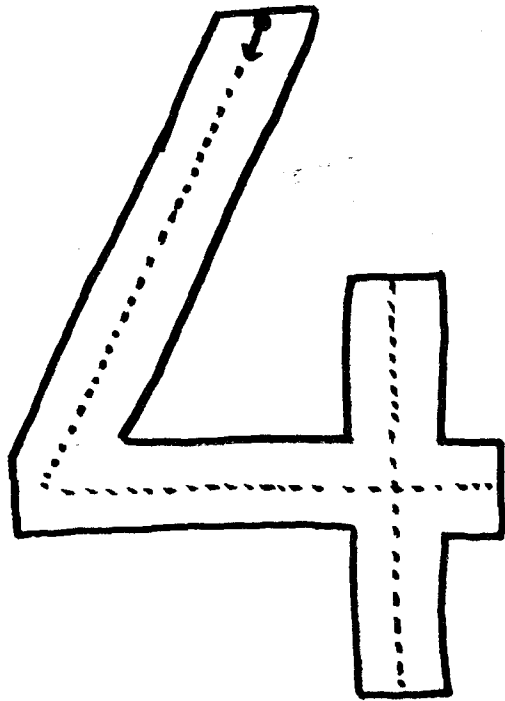

« Dibujar en cada frutero tantas frutas como indica el cardinal. Realizar las grafías.

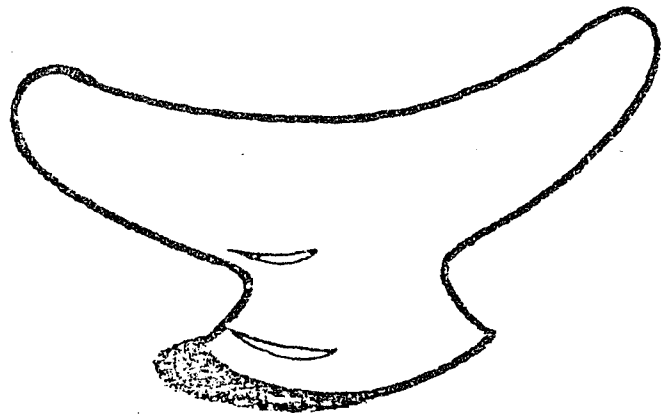

2



3

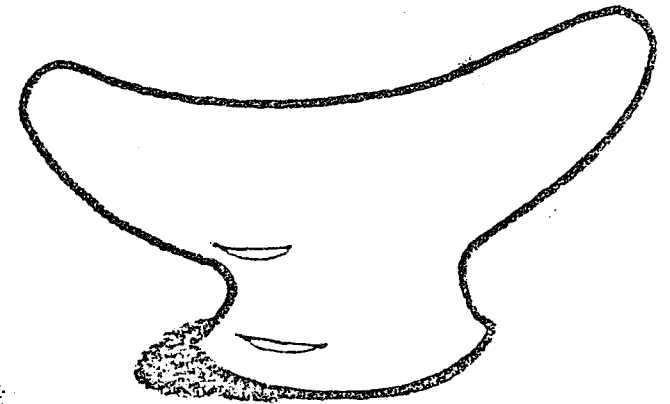

4

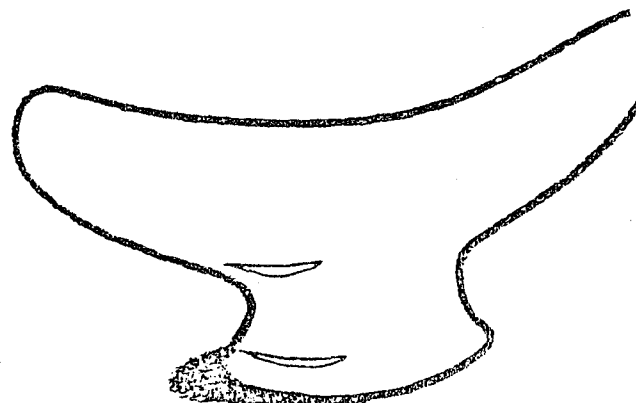
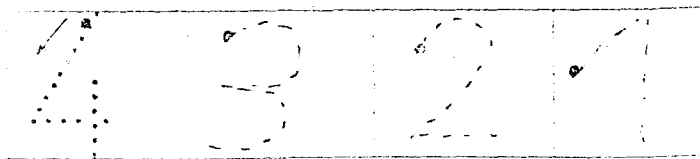
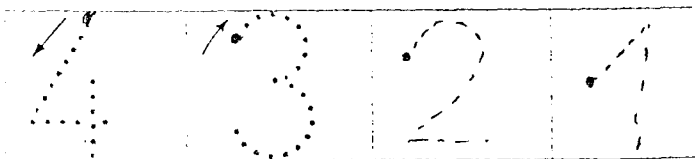

1

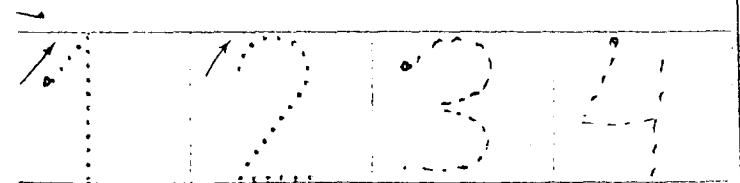

Pon el número de botones que lleva cada niña

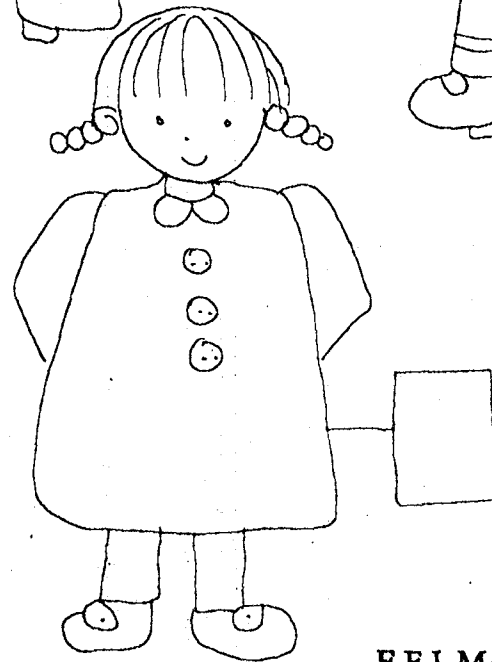
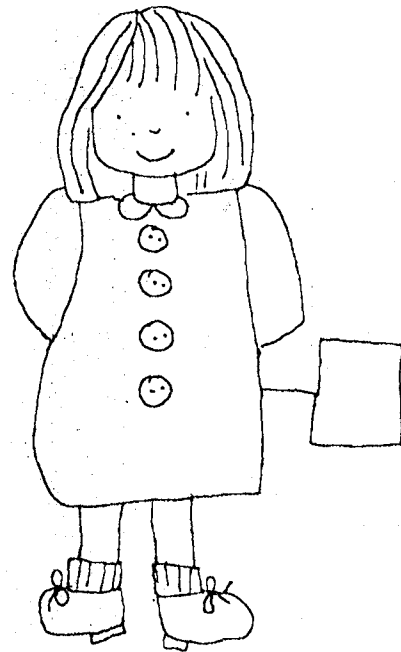
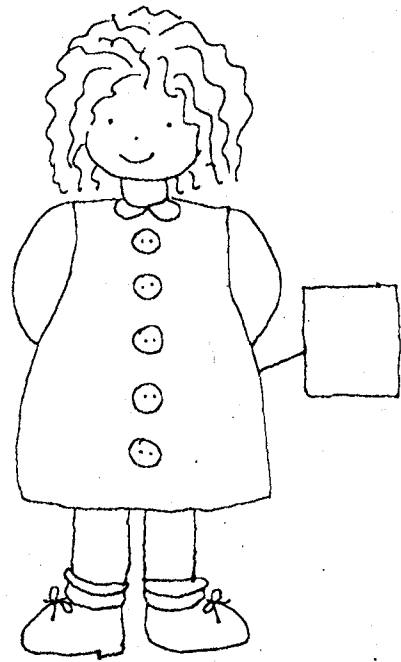

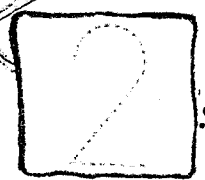
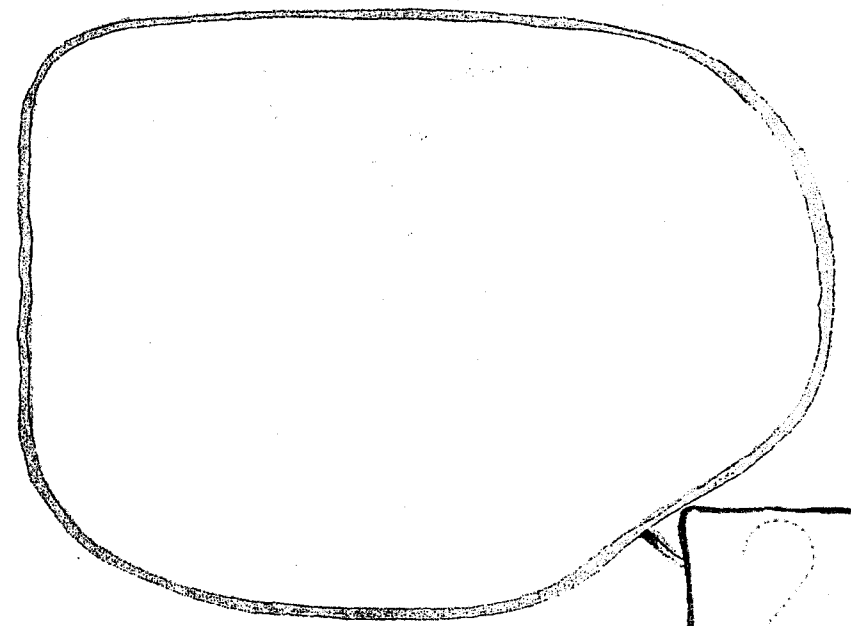
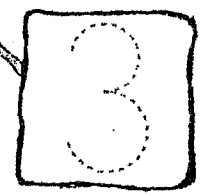
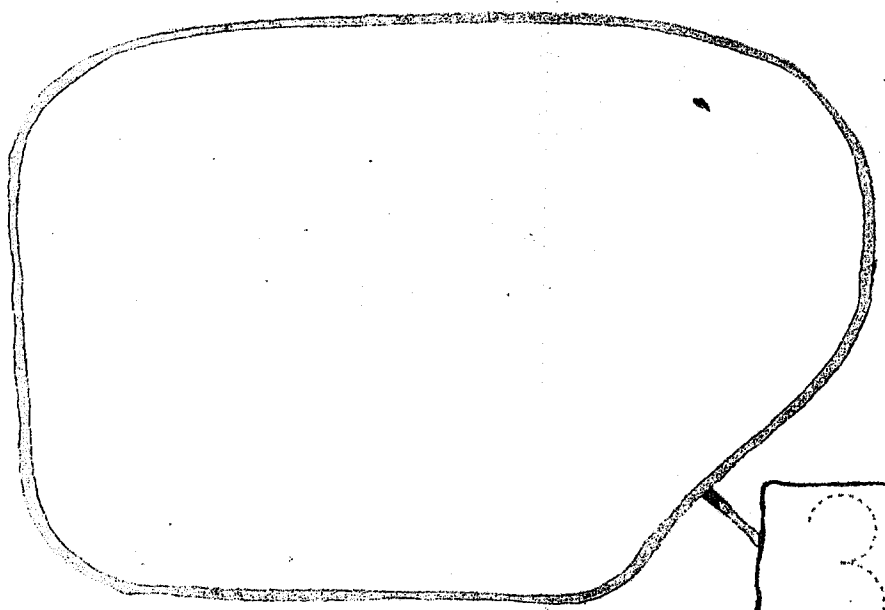
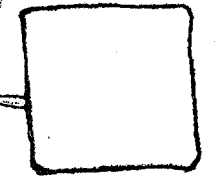
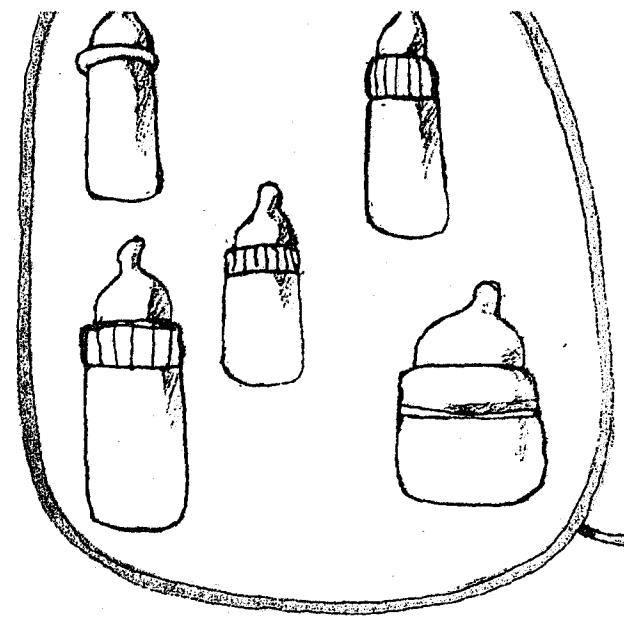
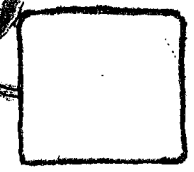
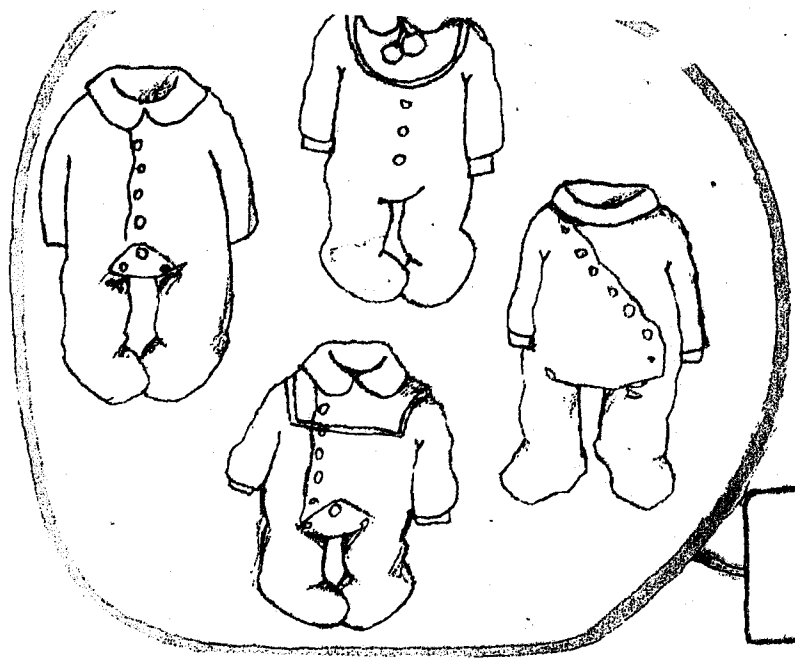

NUESTRO AMIGO QUIERE LLEGAR AL COLE. ¿LO AYUDAMOS?

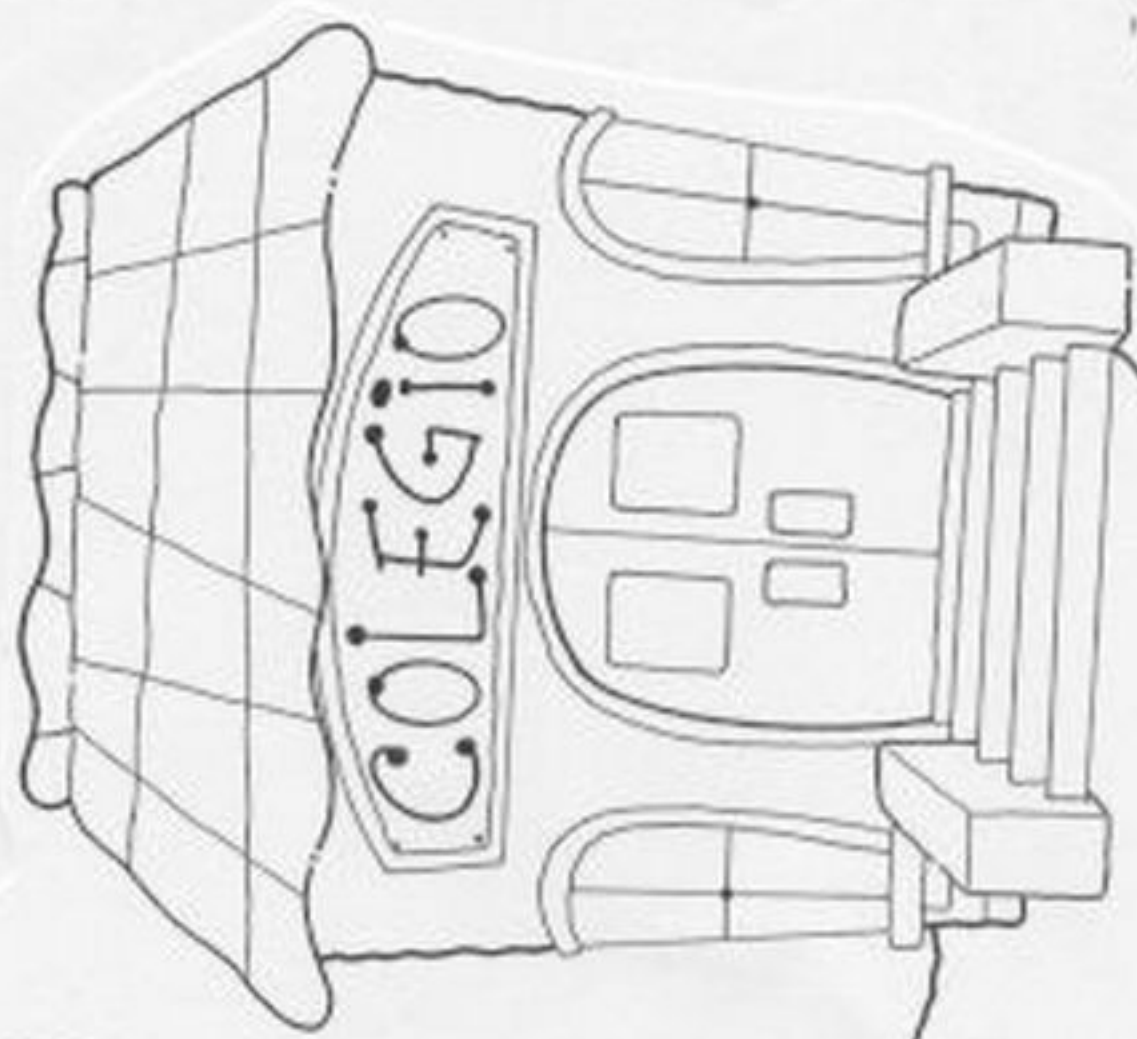

E.E.I. MAR DE ALBORÁN



E.E.I. MAR DE ALBORÁN

Colorea y recorta las distintas partes del cuerpo

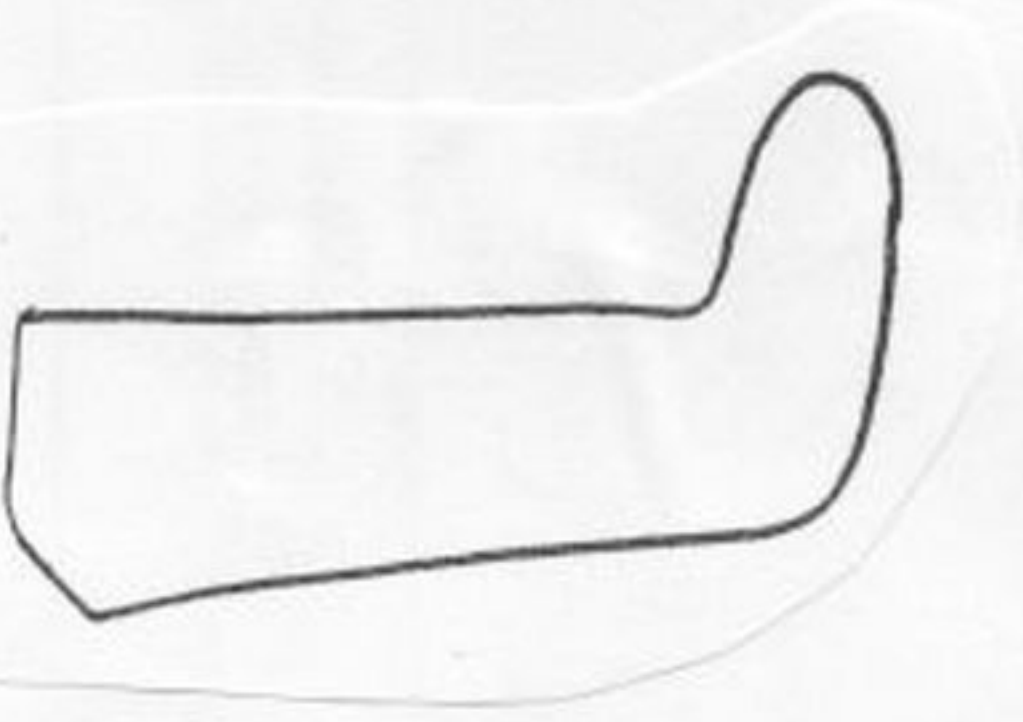
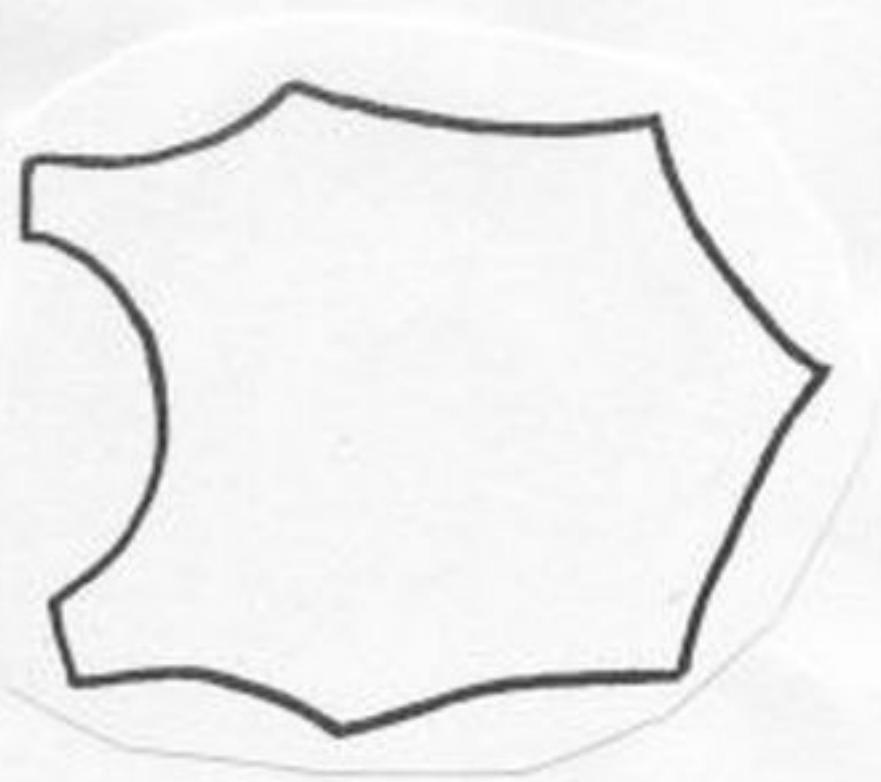



E.E.I. MAR DE ALBORÁN

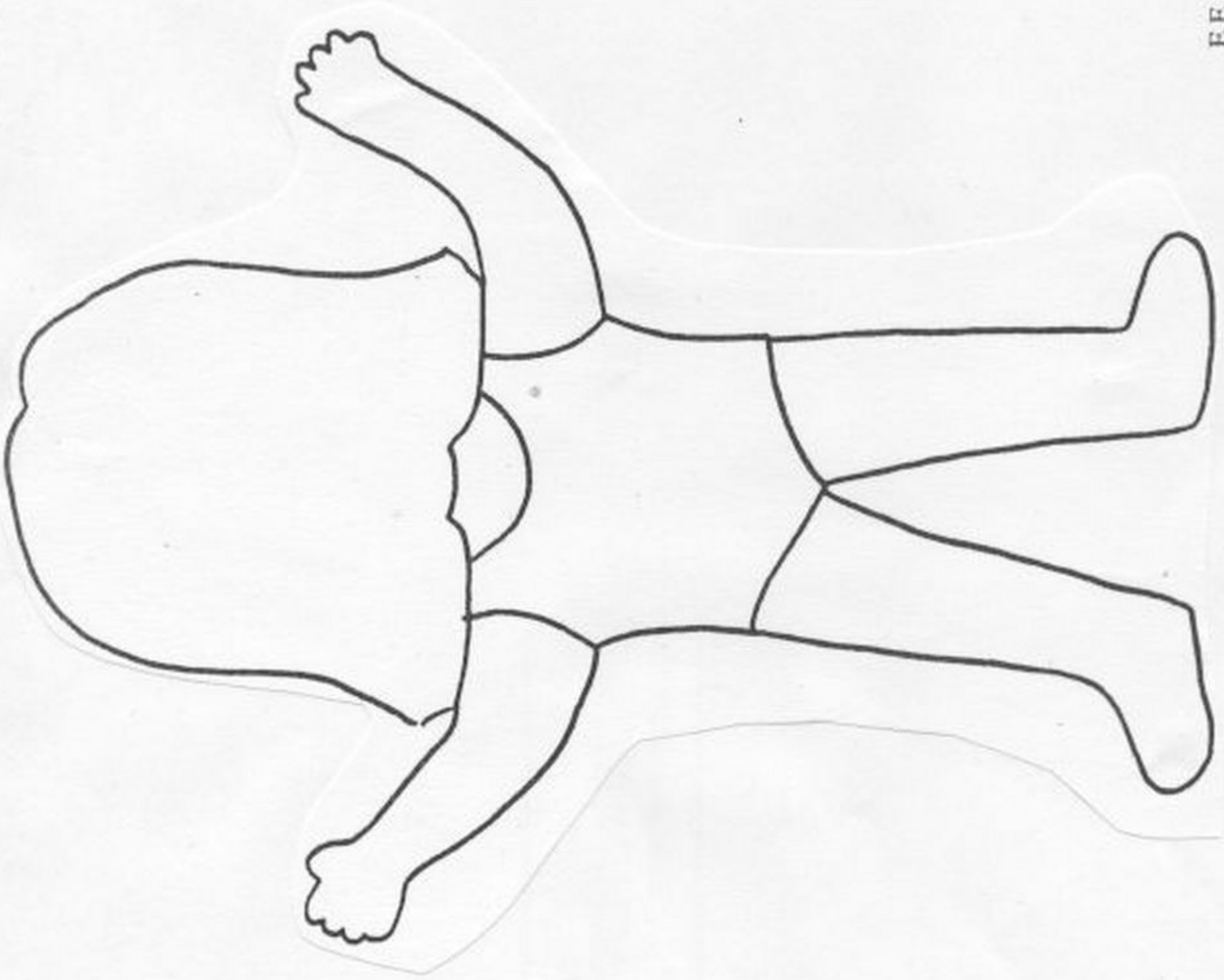



E.E.I. MAR DE ALBORÁN

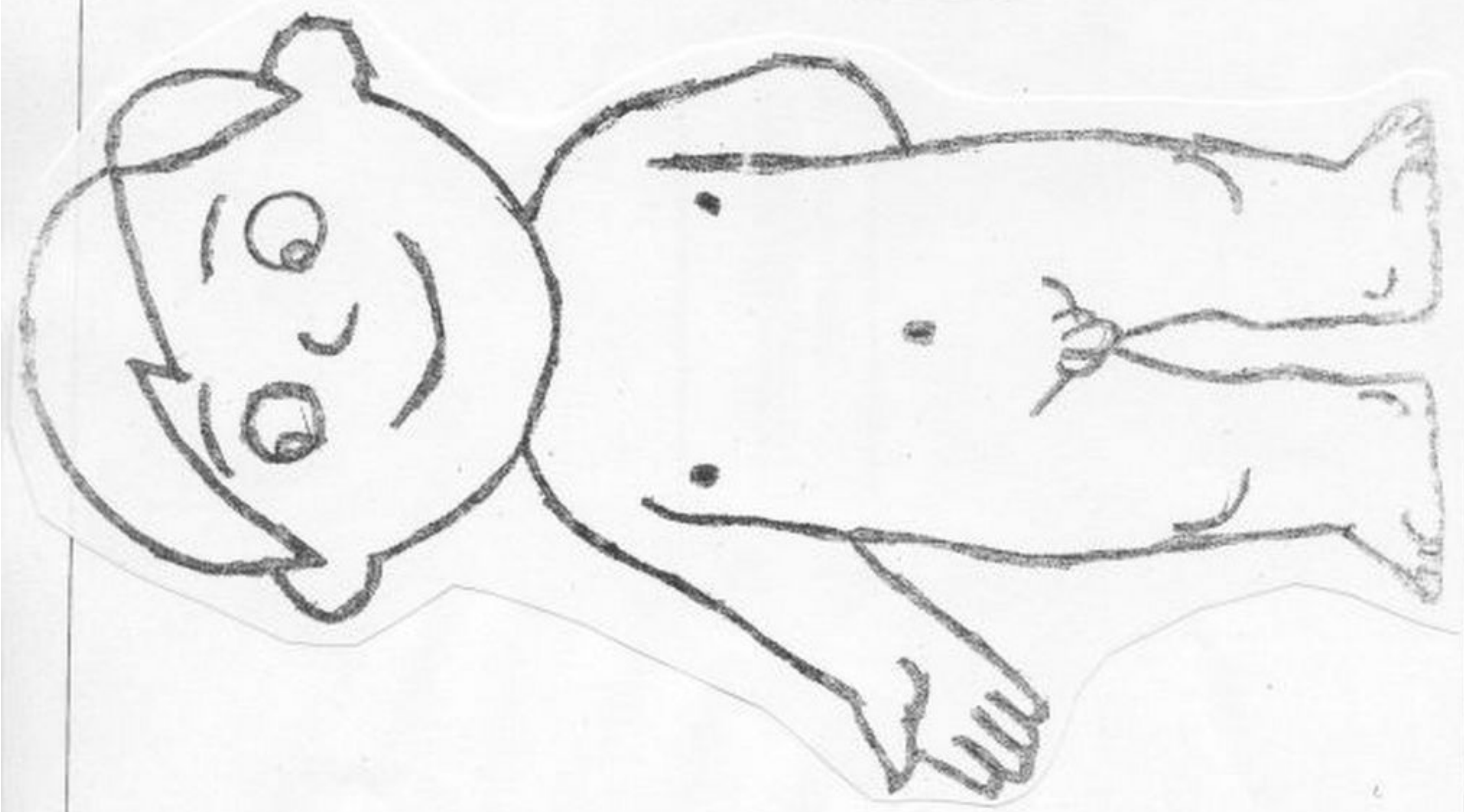
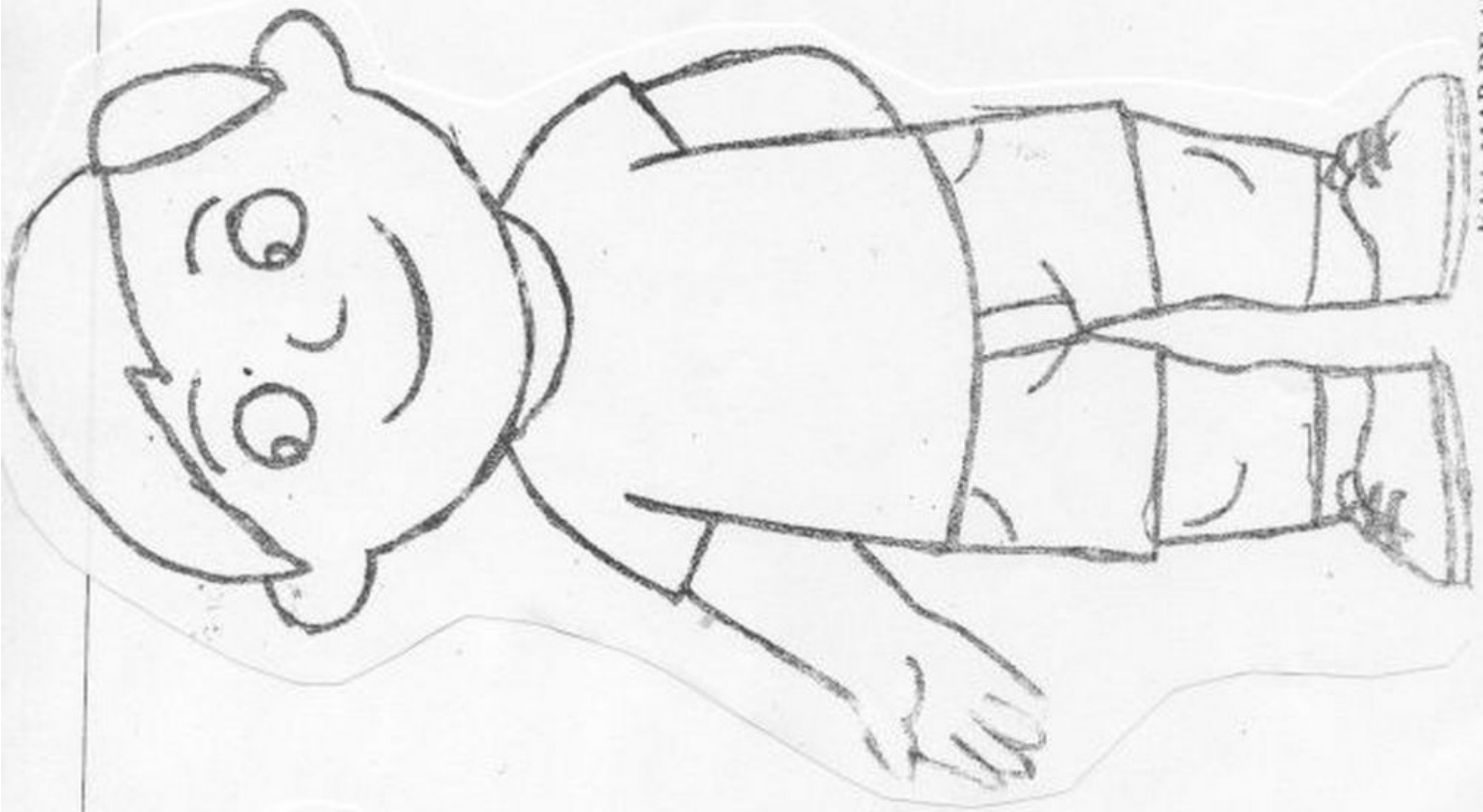



E.E.I. MAR DE ALBORÁN

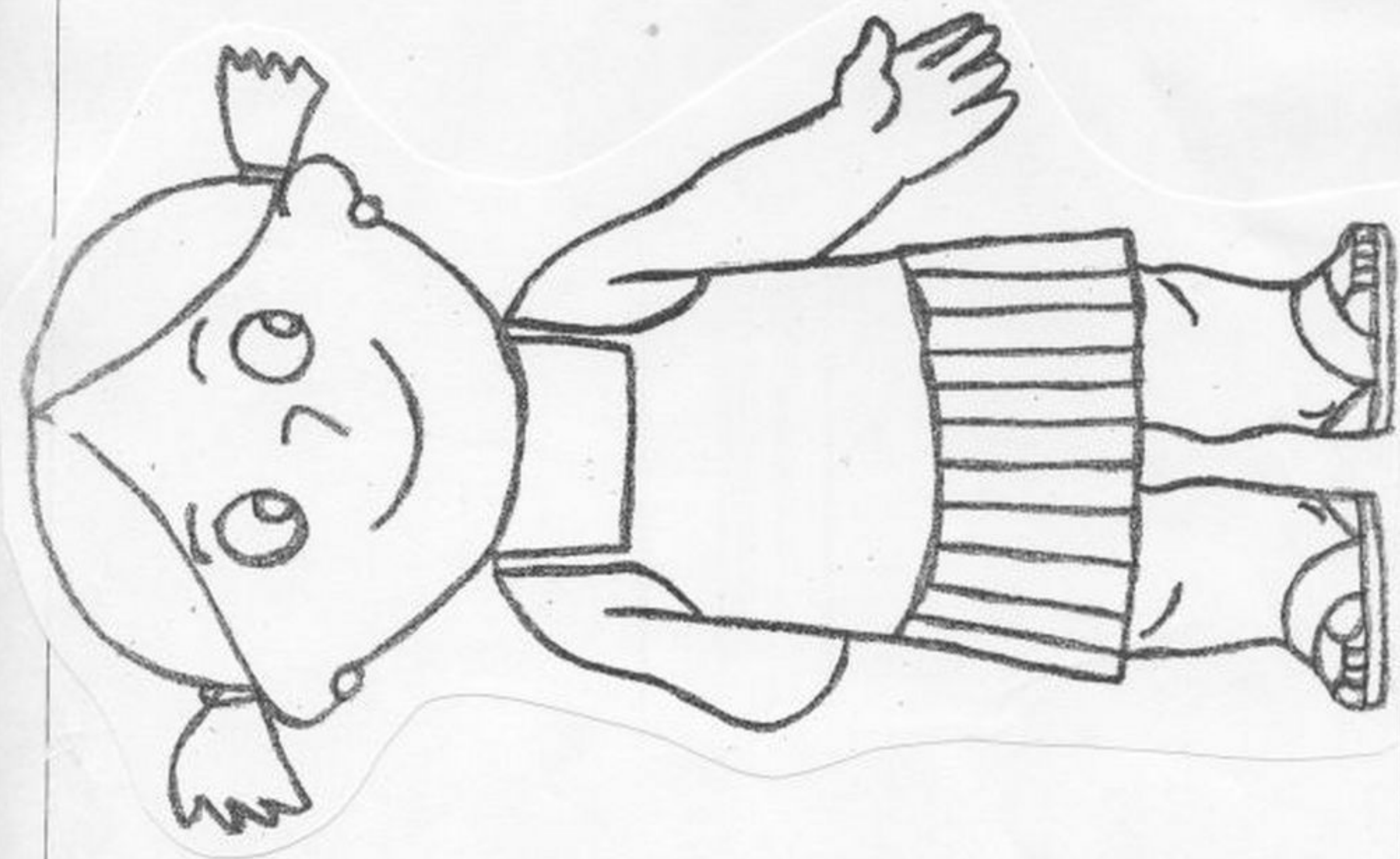
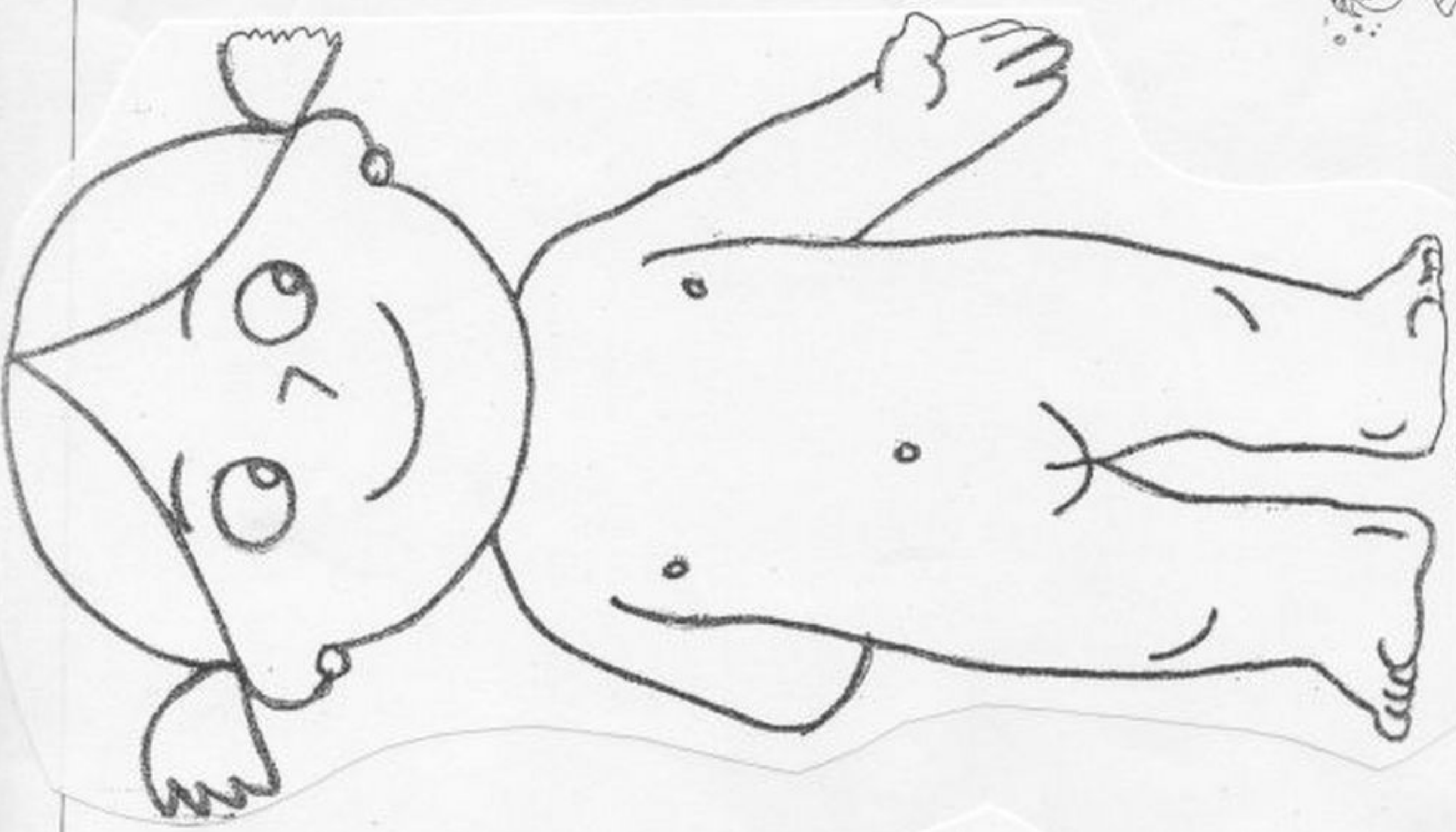



E.E.I. MAR DE ALBORÁN

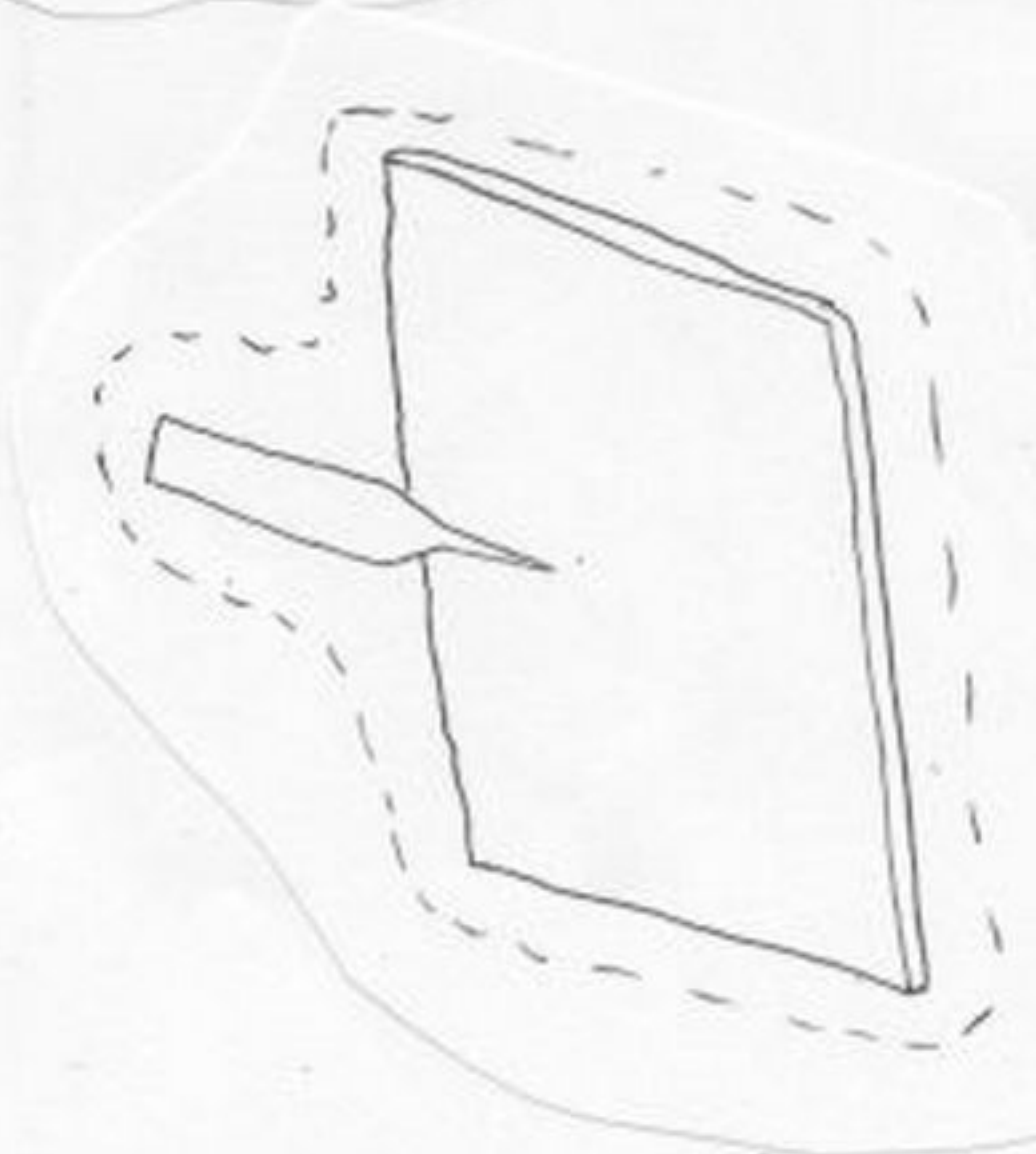
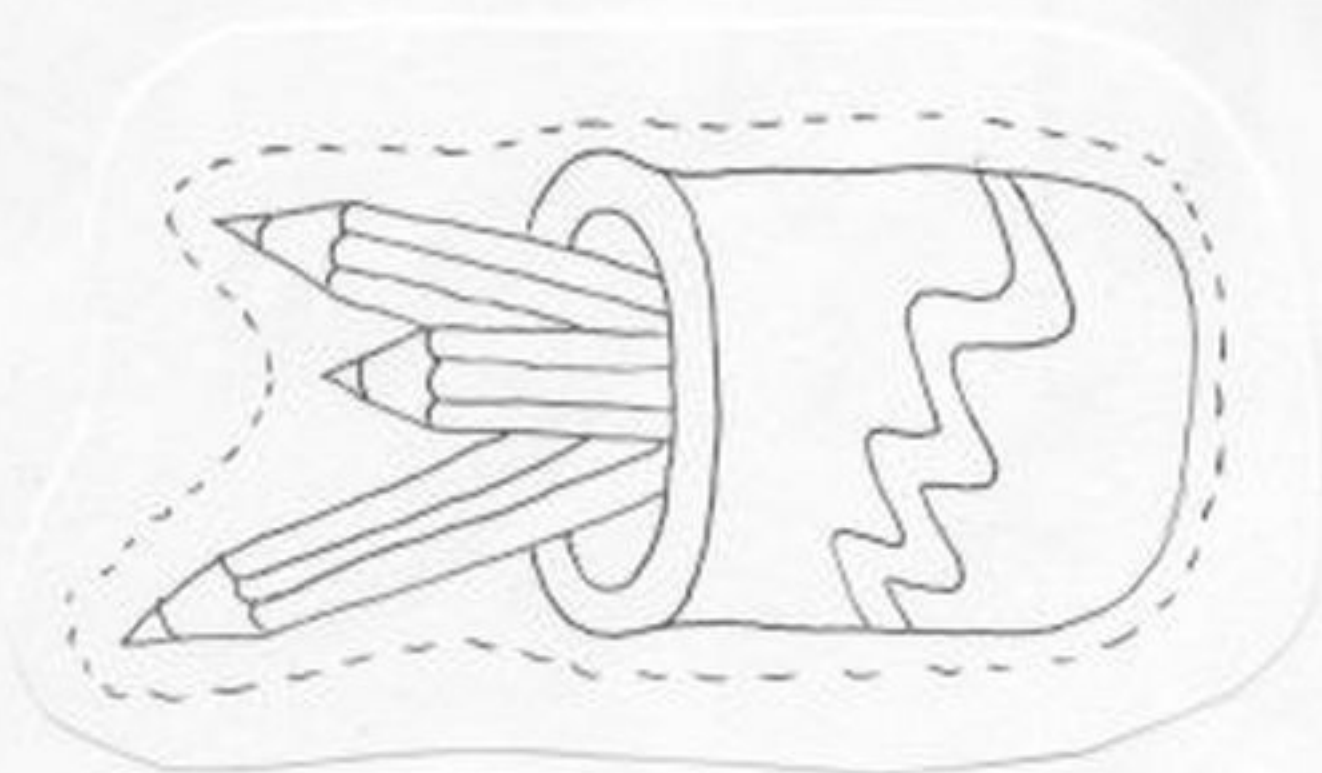
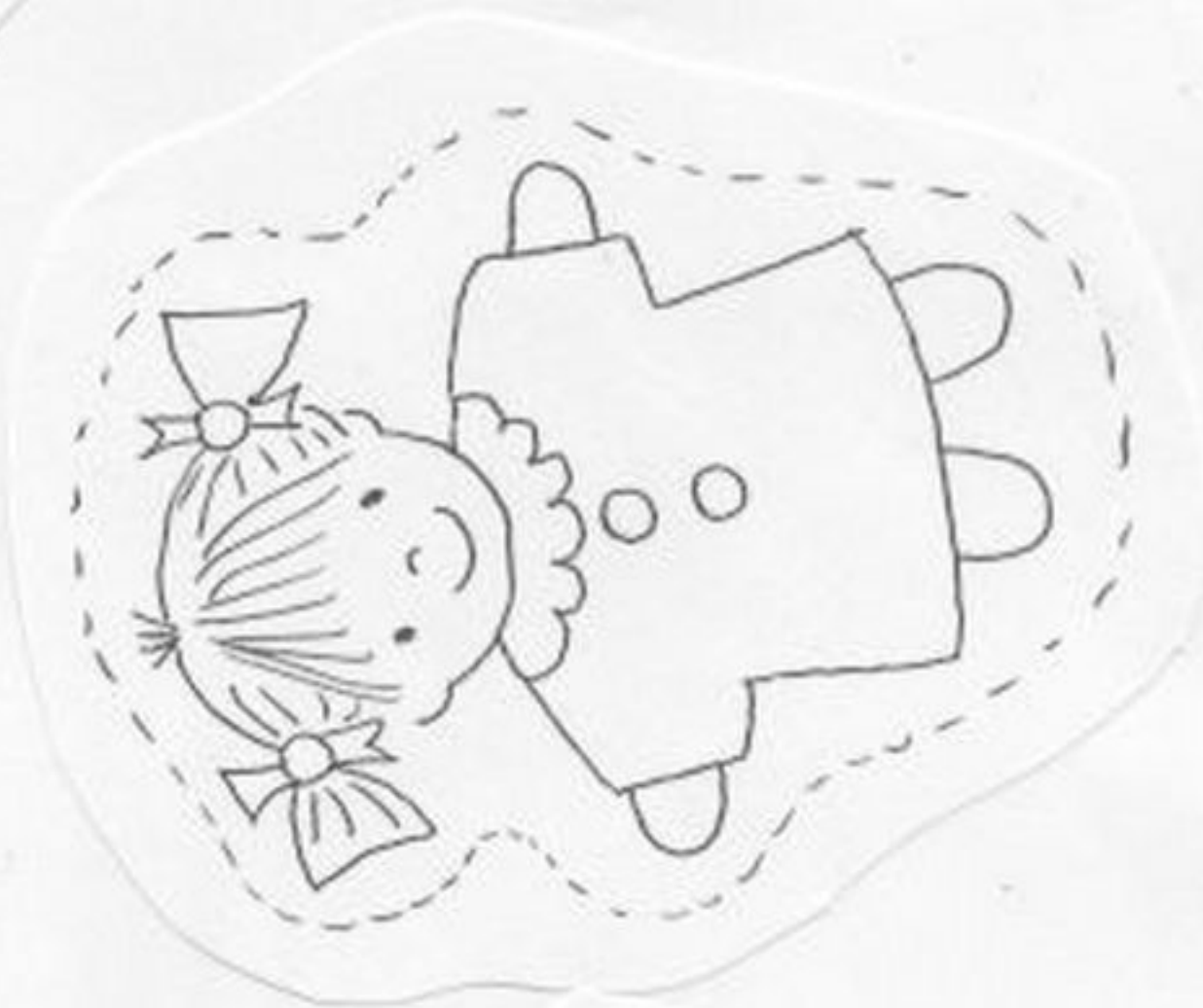
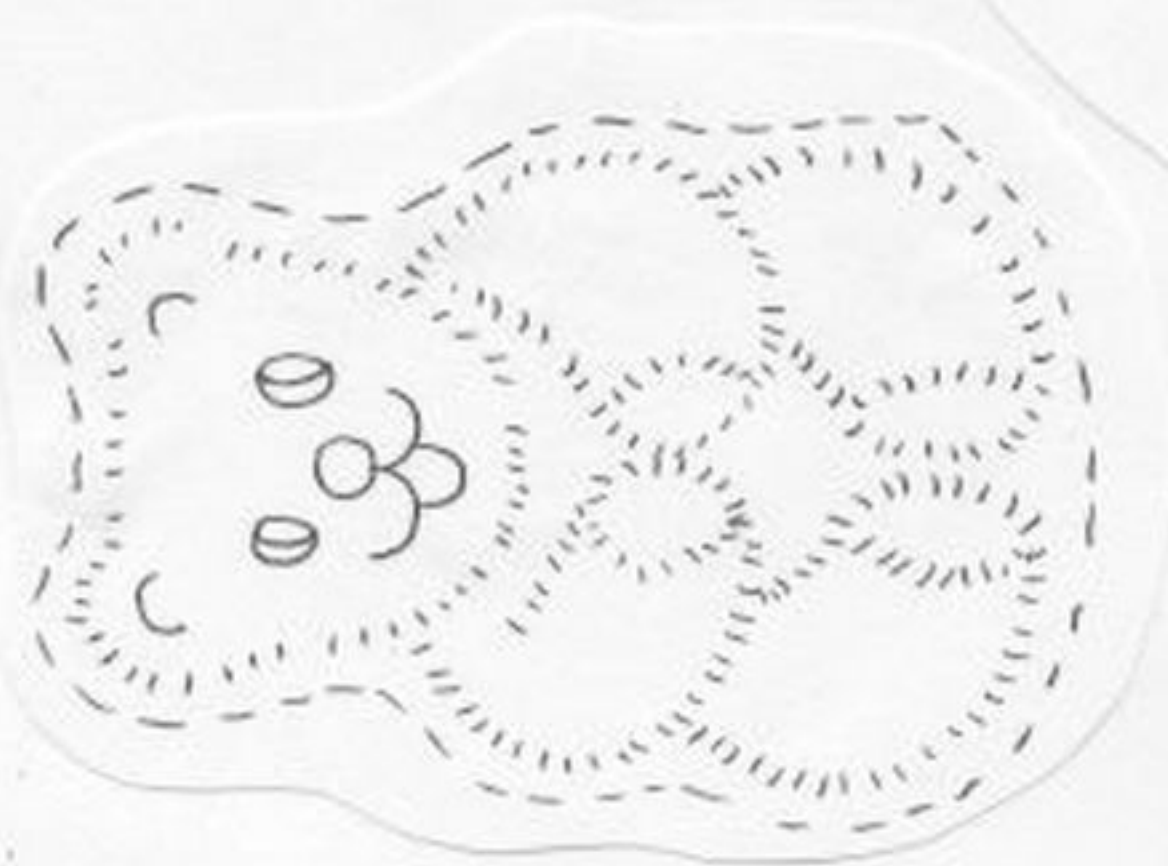

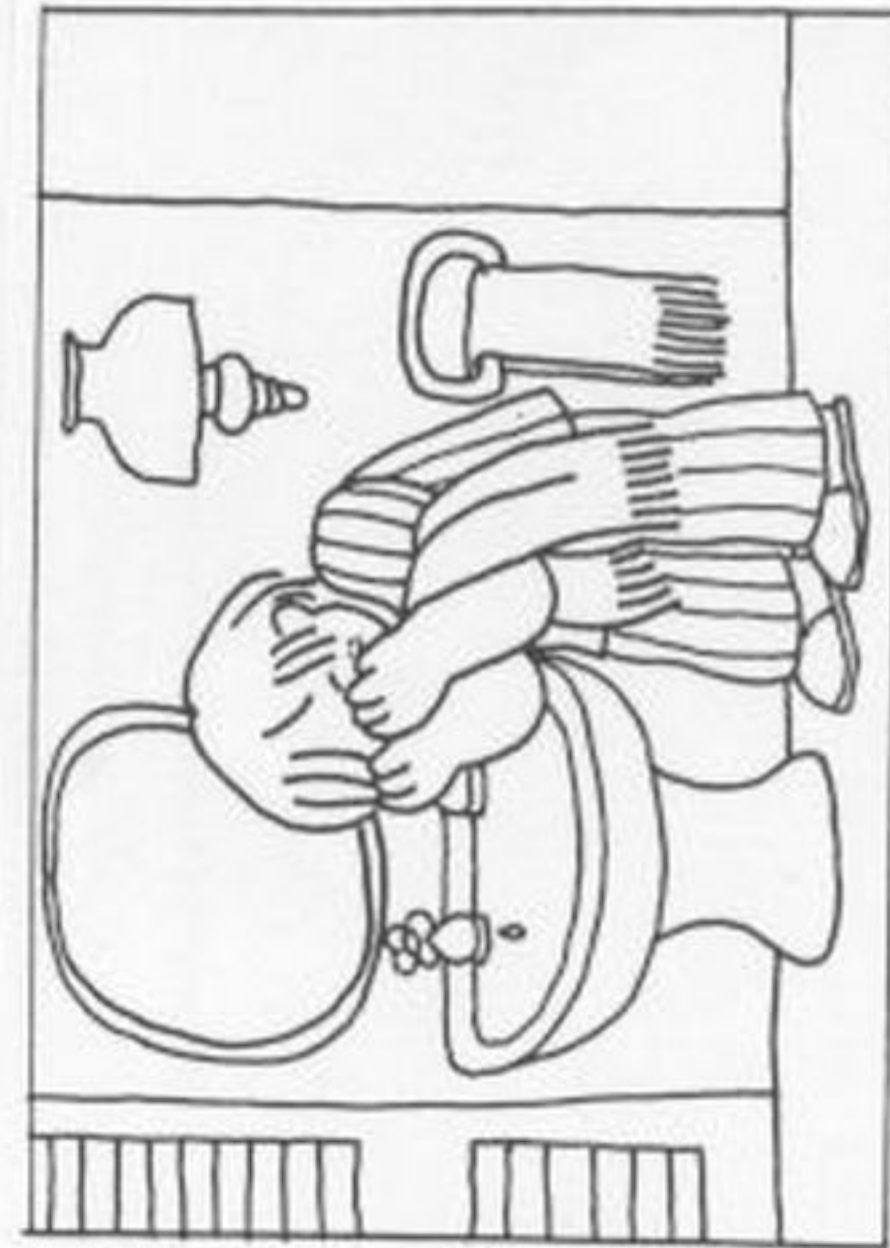
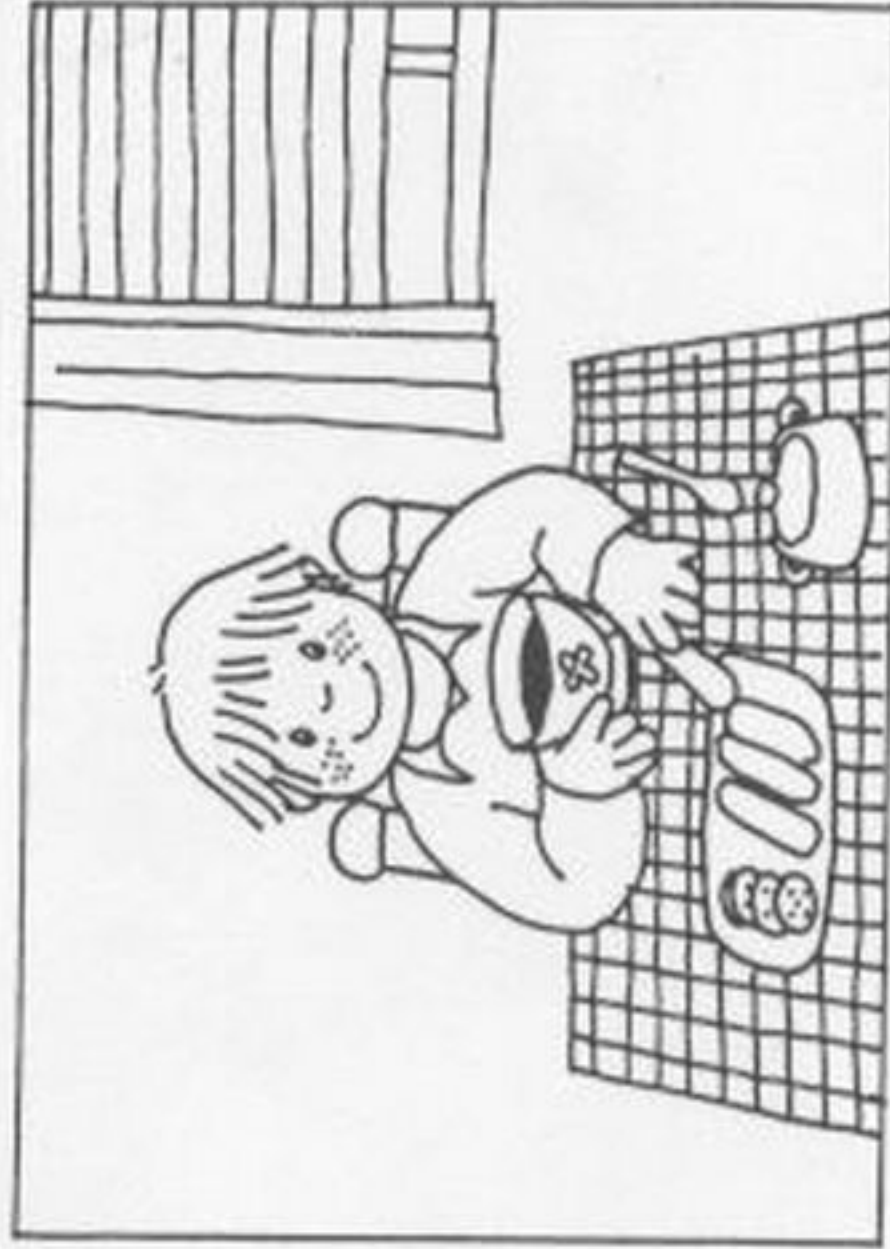



E.E.I. MAR DE ALBORÁN

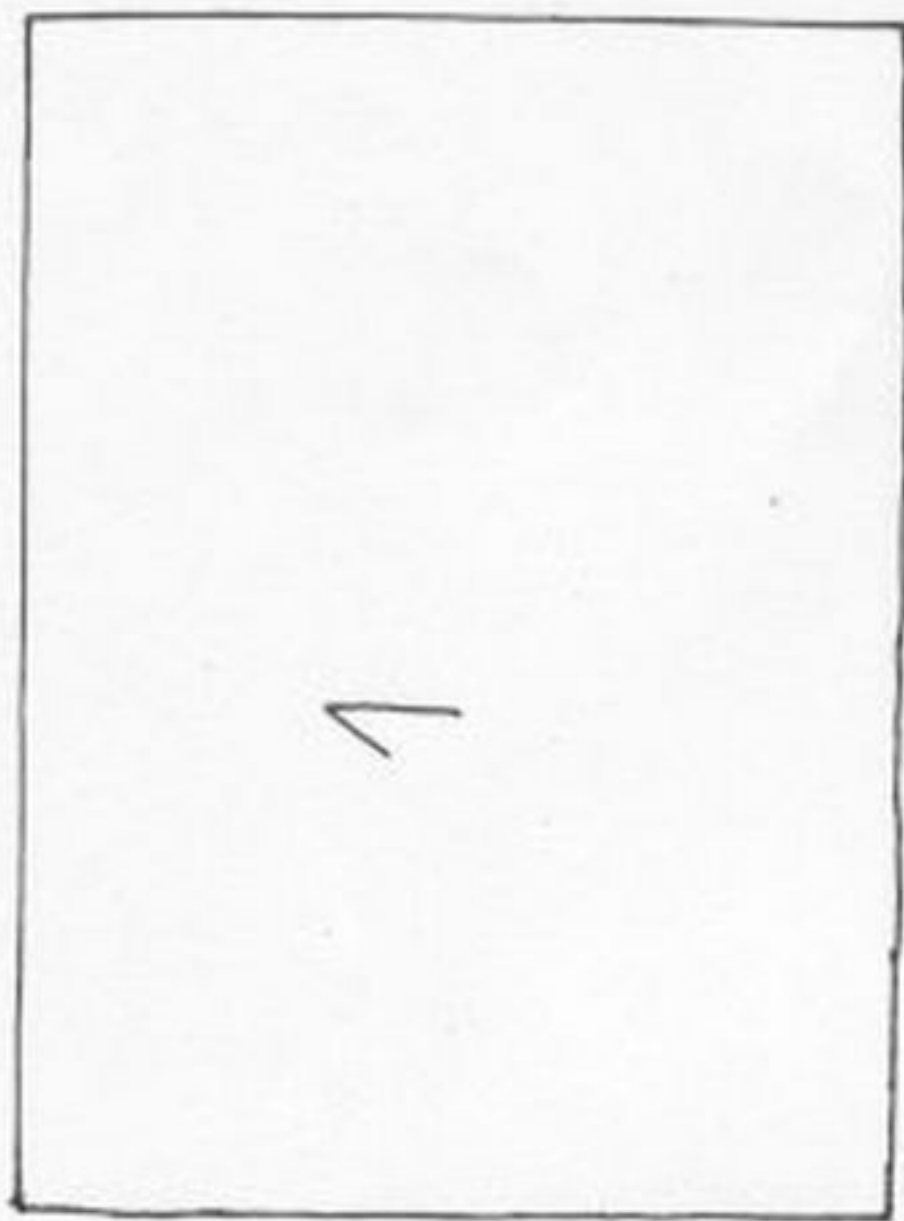
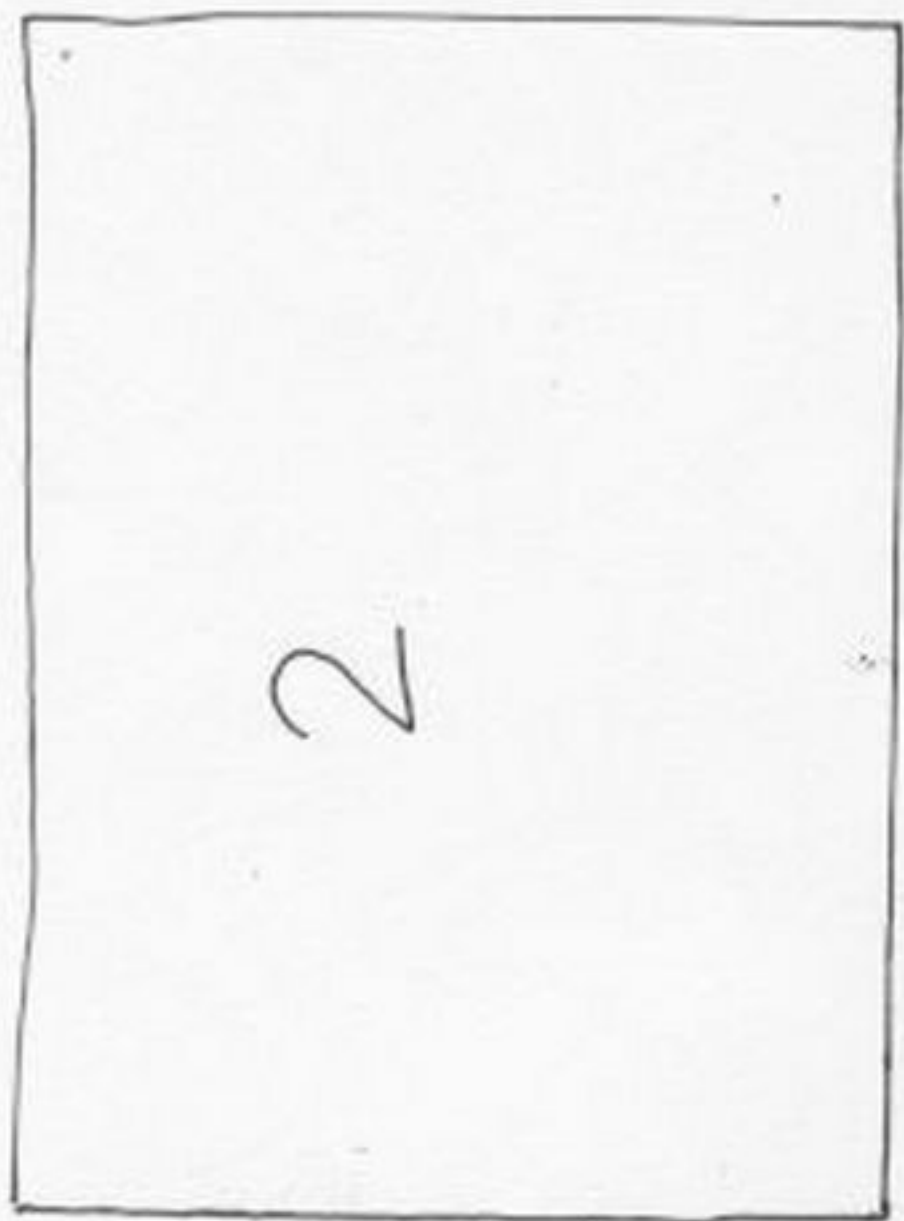



E.E.I. MAR DE ALBORÁN

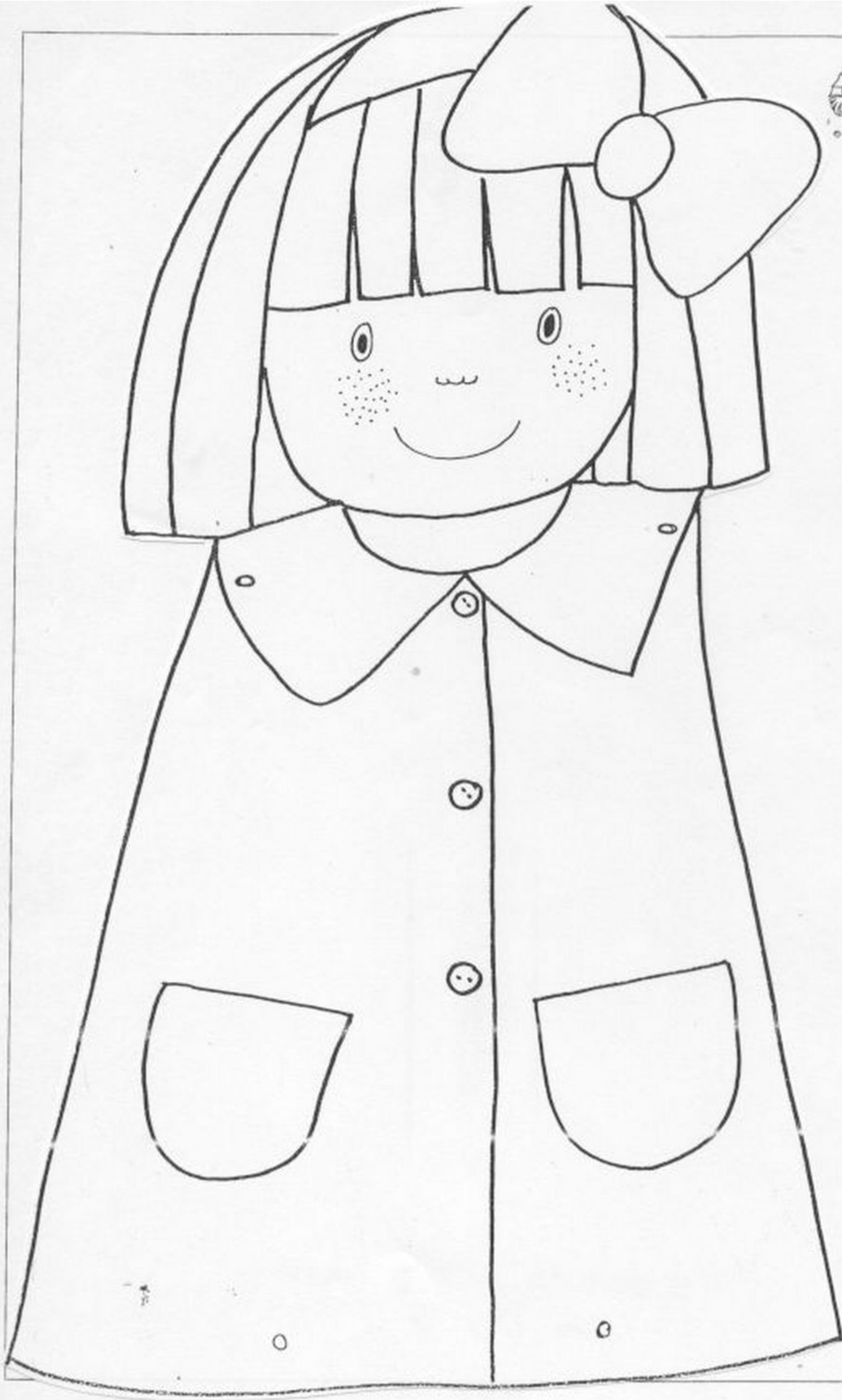



E.E.I. MAR DE ALBORÁN

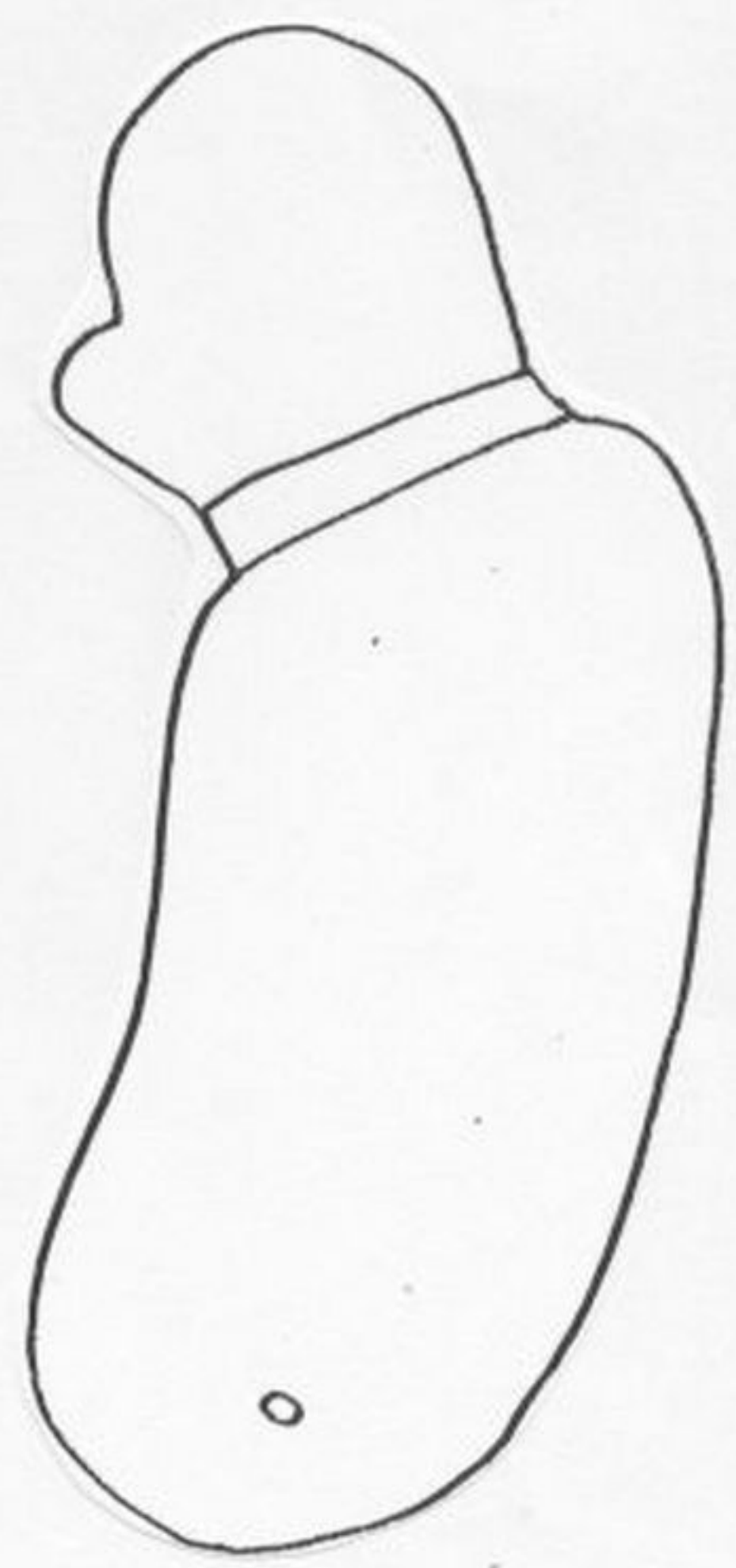
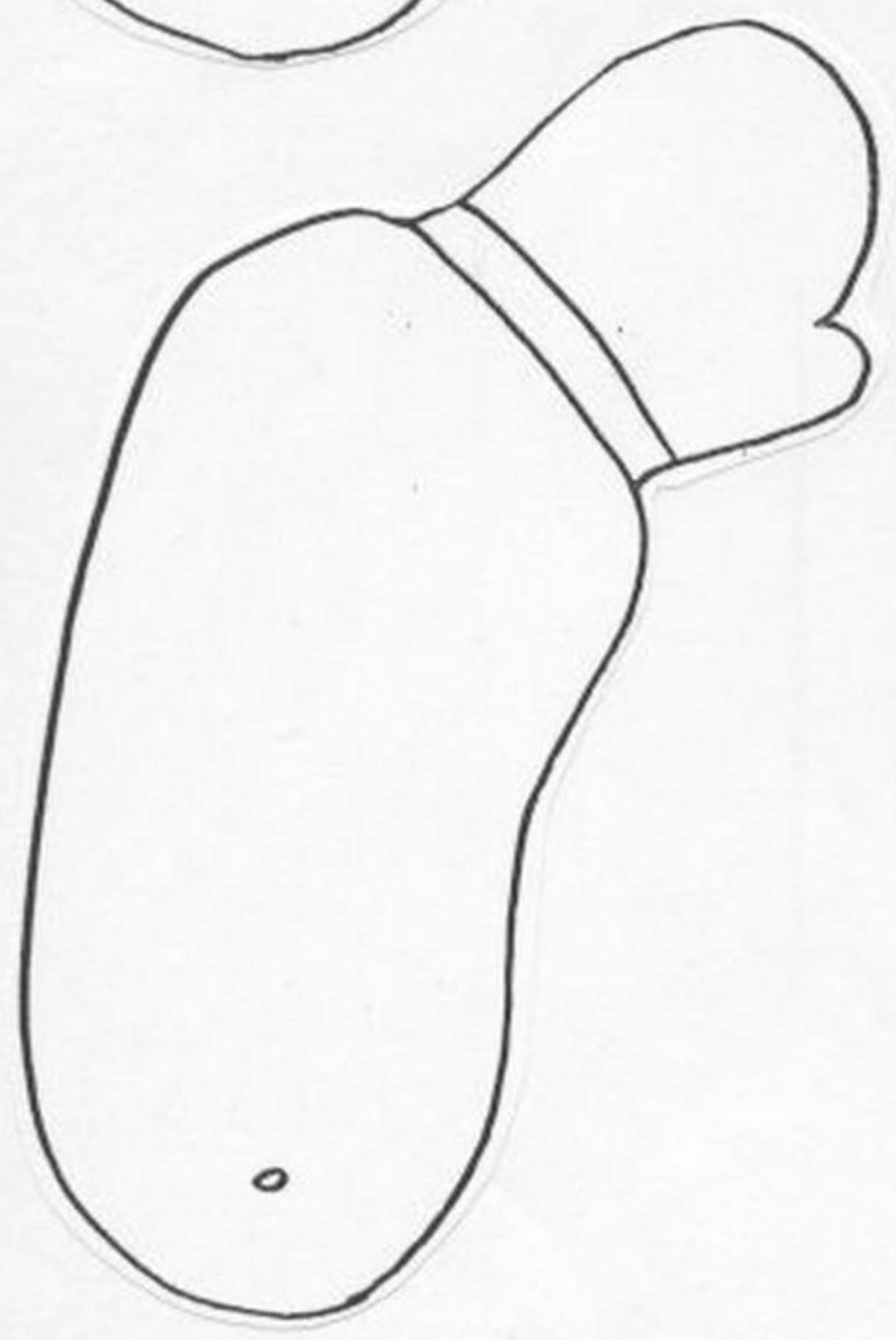
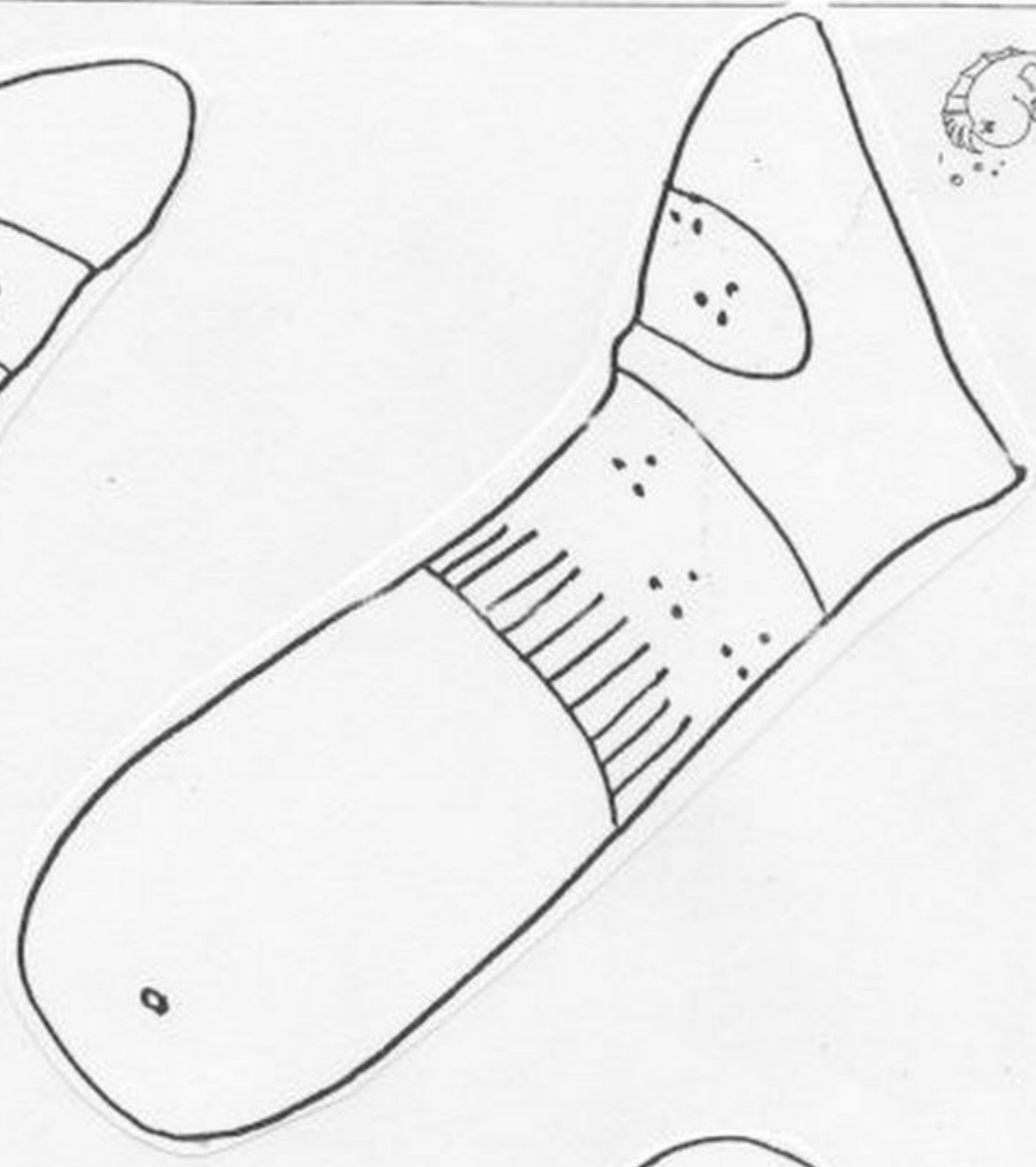
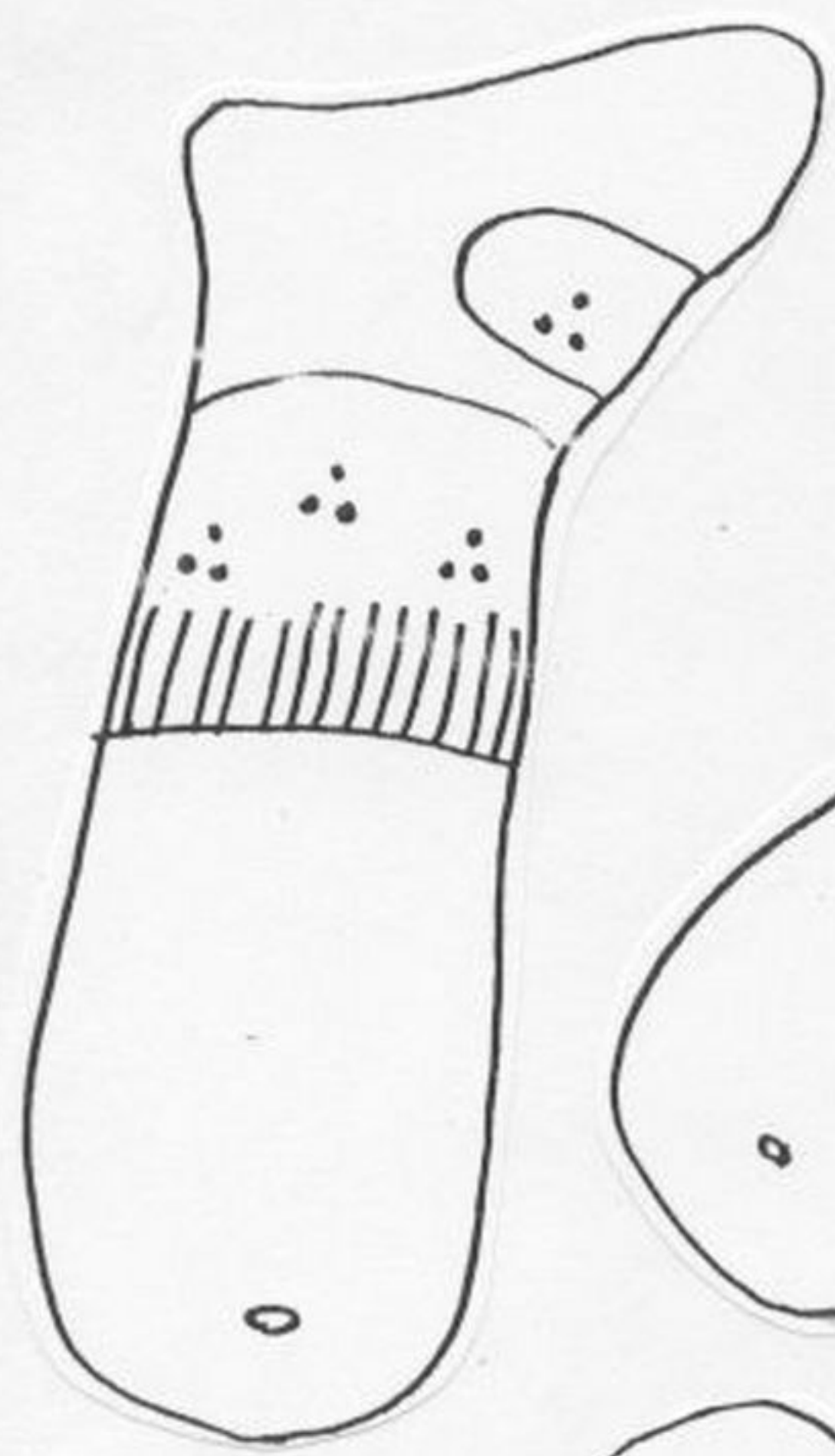



E.E.I. MAR DE ALBORÁN





E.E.I. MAR DE ALBORÁN

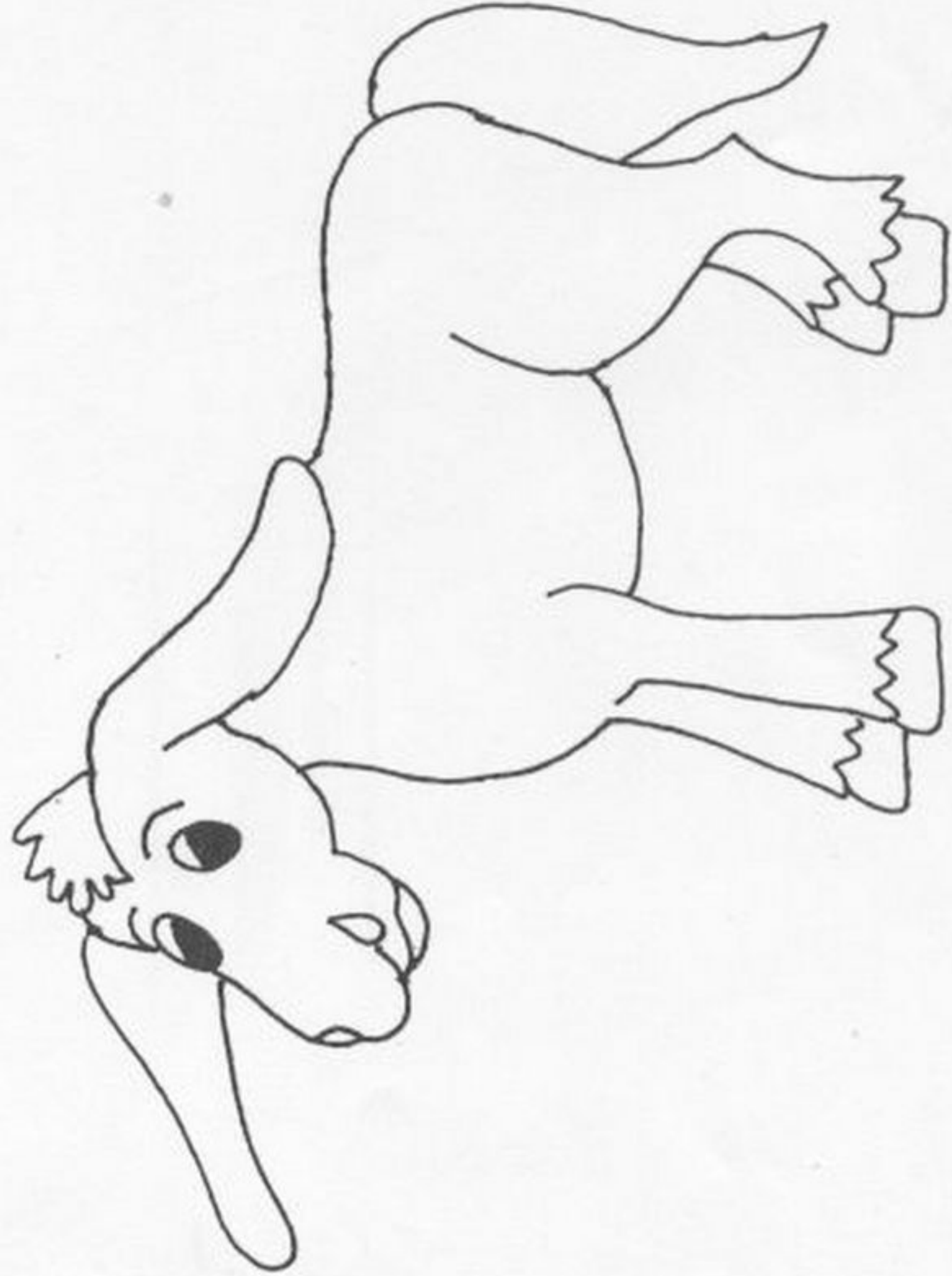



E.E.I. MAR DE ALBORÁN

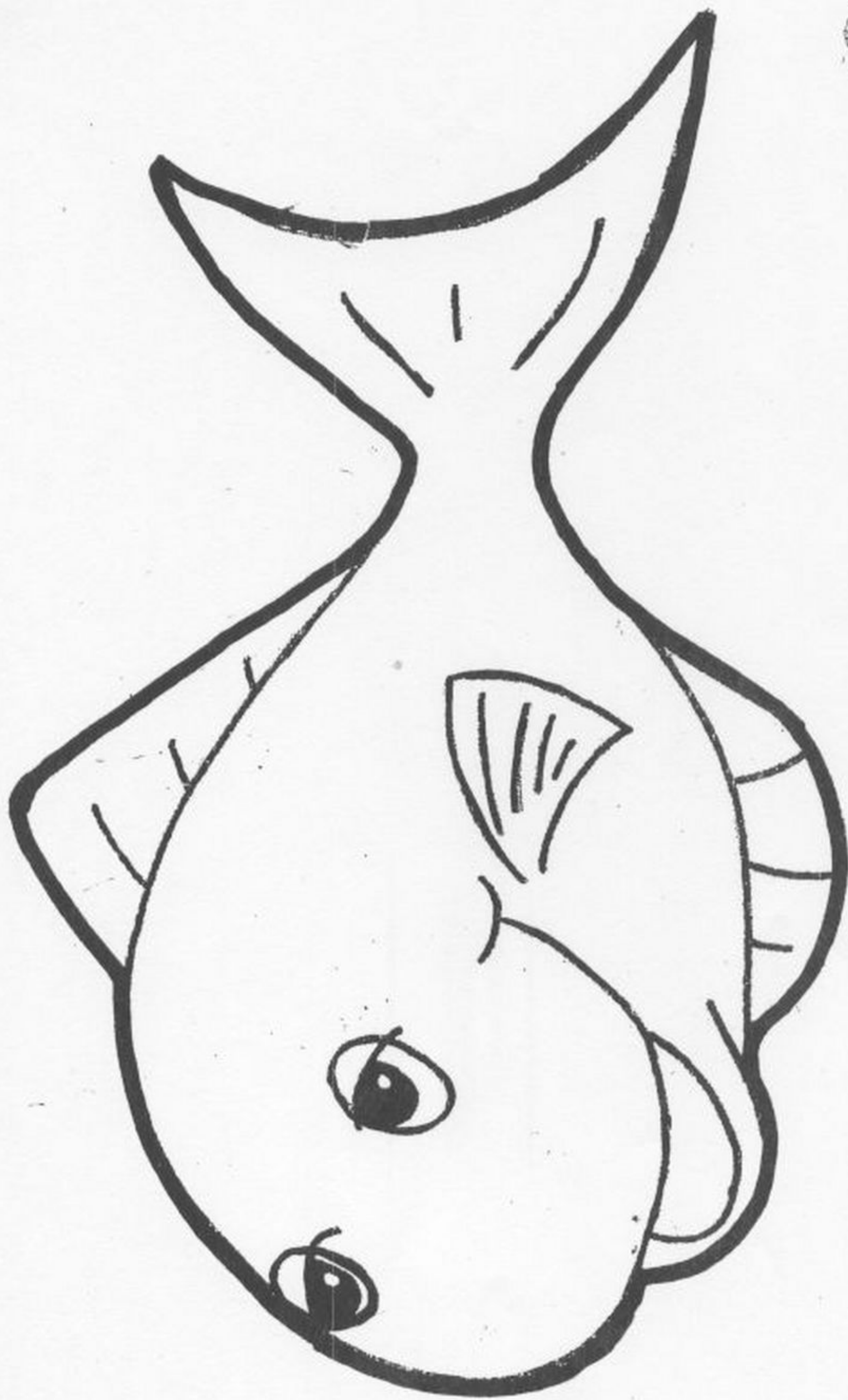



E.E.I. MAR DE ALBORÁN



BIEN/MAL

Mira el dibujo. Echa en donde veas
una cosa mal hecha. Pinta lo que está
bien hecho.



E.E.I. MAR DE ALBORÁN